

MILITARY SPECIFICATION
CRATES, WOOD, OPEN AND COVERED

This amendment forms a part of Military Specification MIL-C-52950A, dated 20 March 1991 and is approved for use by all Departments and Agencies of the Department of Defense.

PAGE 1

Document identifier: Date of superseded document is incorrect. Delete "1 January 1990" and substitute "10 April 1978."

PAGE 22

Project number: Delete "PACK-0793" and substitute "8115-0513."

PAGE 23 THRU PAGE 40

Add Figures 1 thru 18.

PREPARING ACTIVITY:

Army - ME

AMSC N/A

FSC 8115

DISTRIBUTION STATEMENT A. Approved for public release; distribution is unlimited.

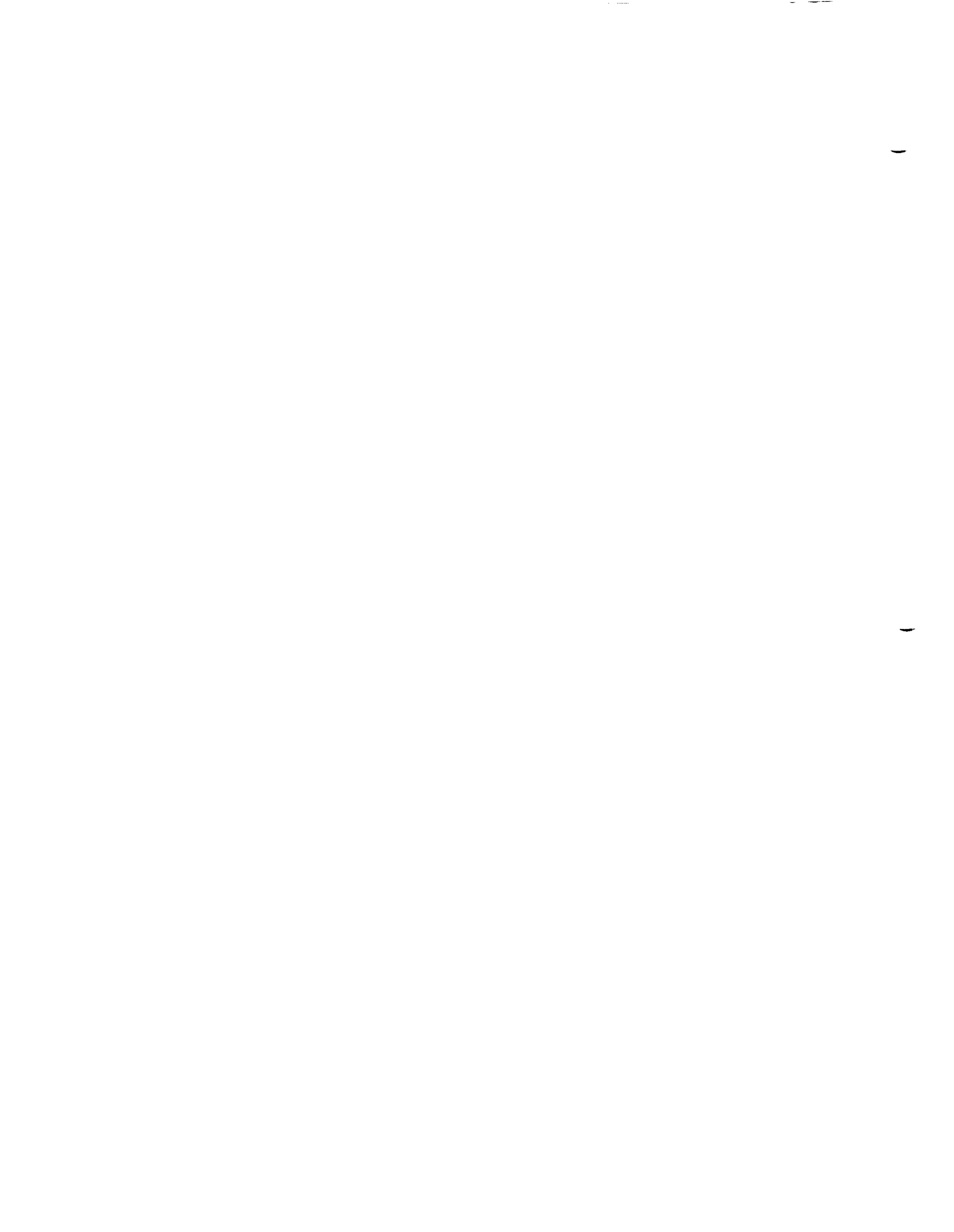

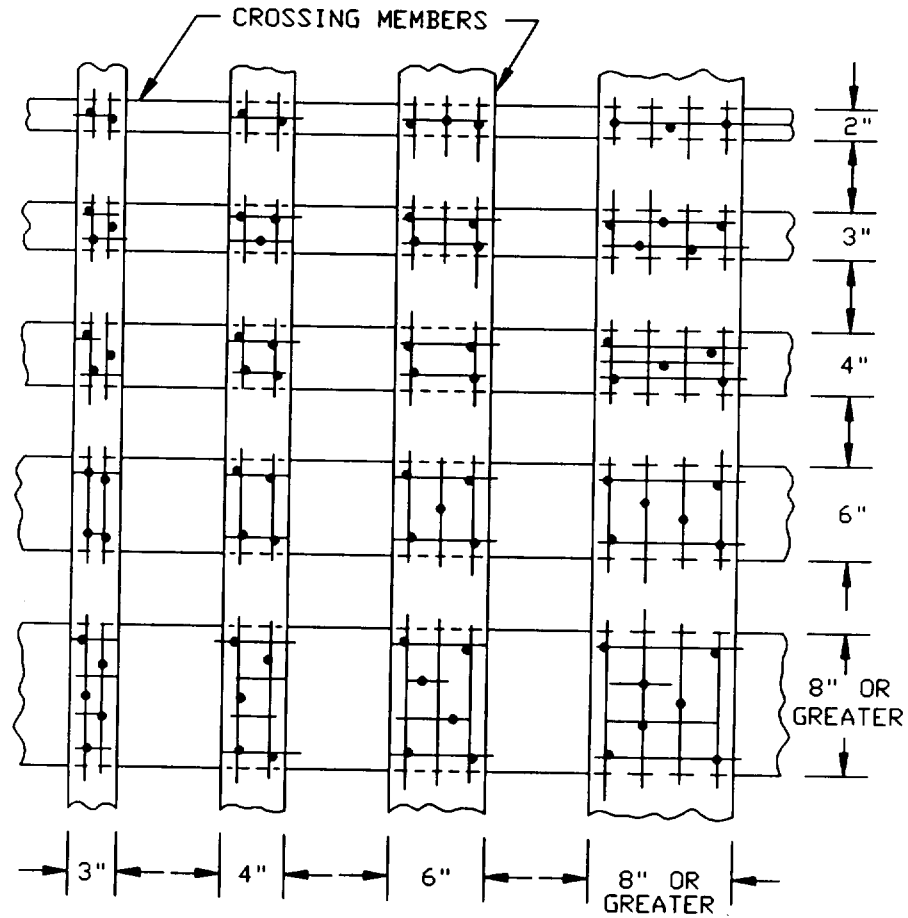
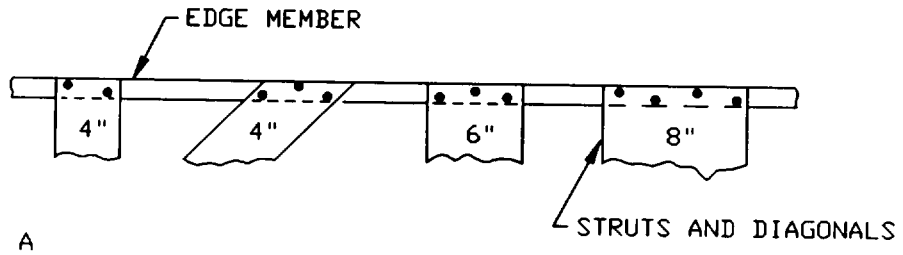

B

FIGURE 1. Nailing patterns. (All widths are nominal. Similar patterns shall be used when boards cross at angles other 90°.)

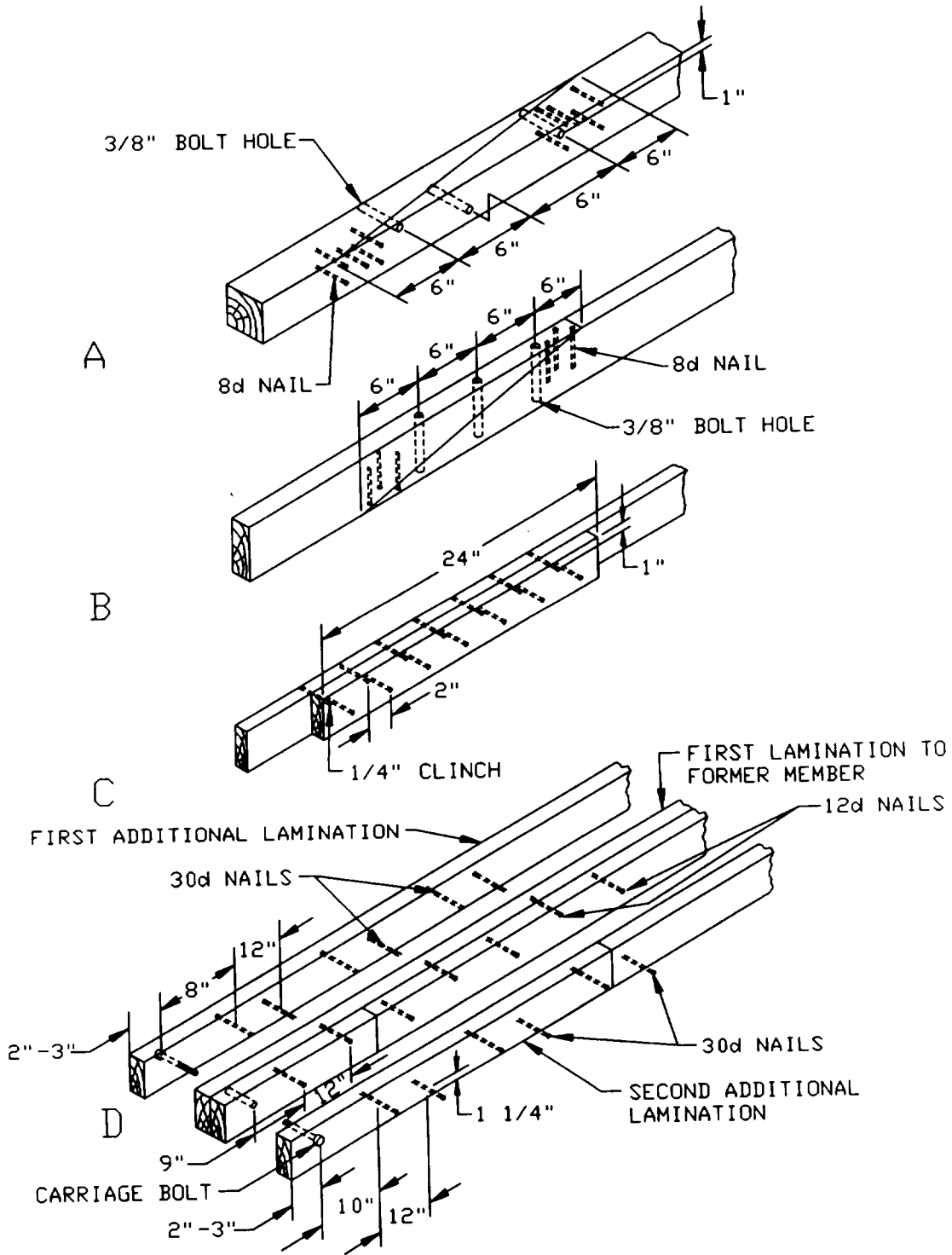

FIGURE 2. Splicing of members; A, splice of 4-by-4 inch or 4-by-6 inch skids; B, splice of 2-inch member; C, splice of 1-inch member; D, lamination of skid.

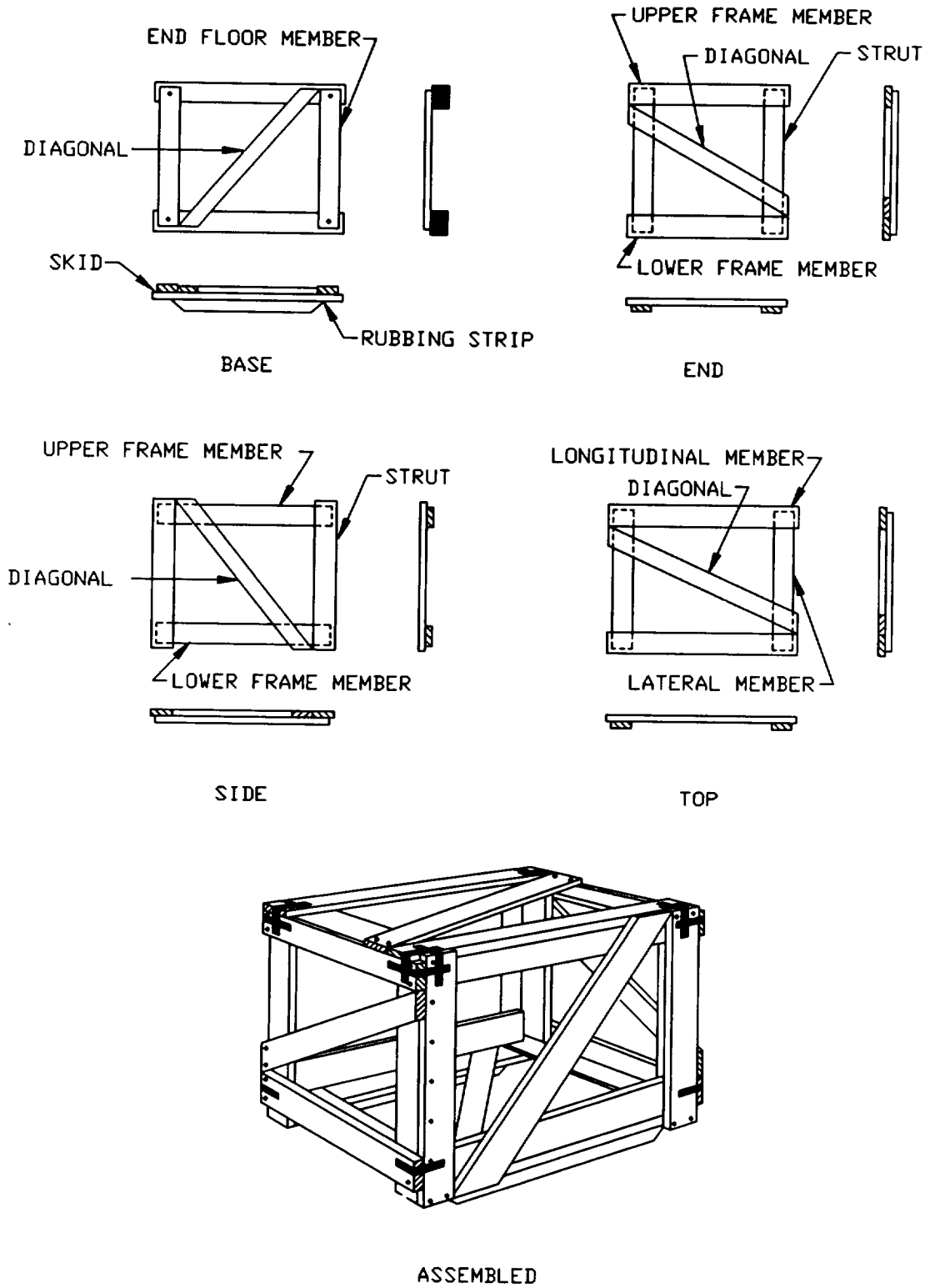

FIGURE 3. Type I, style A crate assembly.

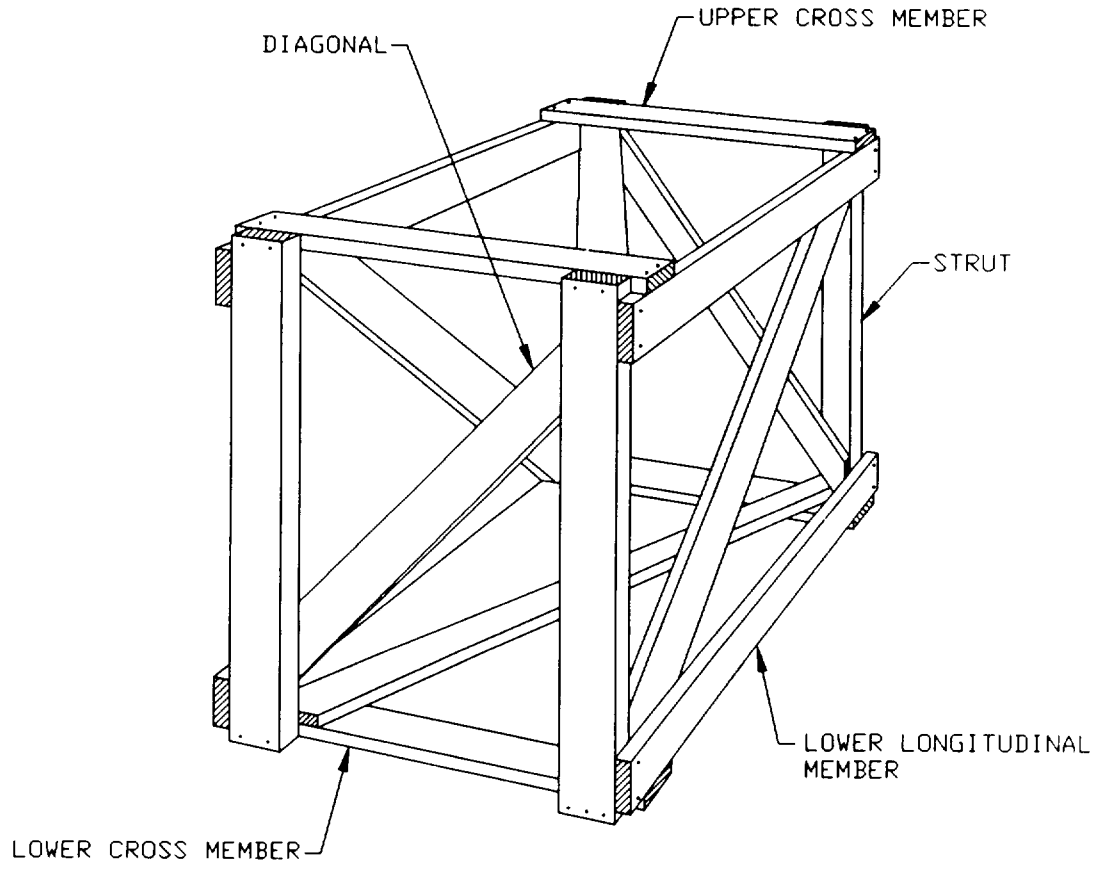

FIGURE 4. Type I, style B crate assembly.

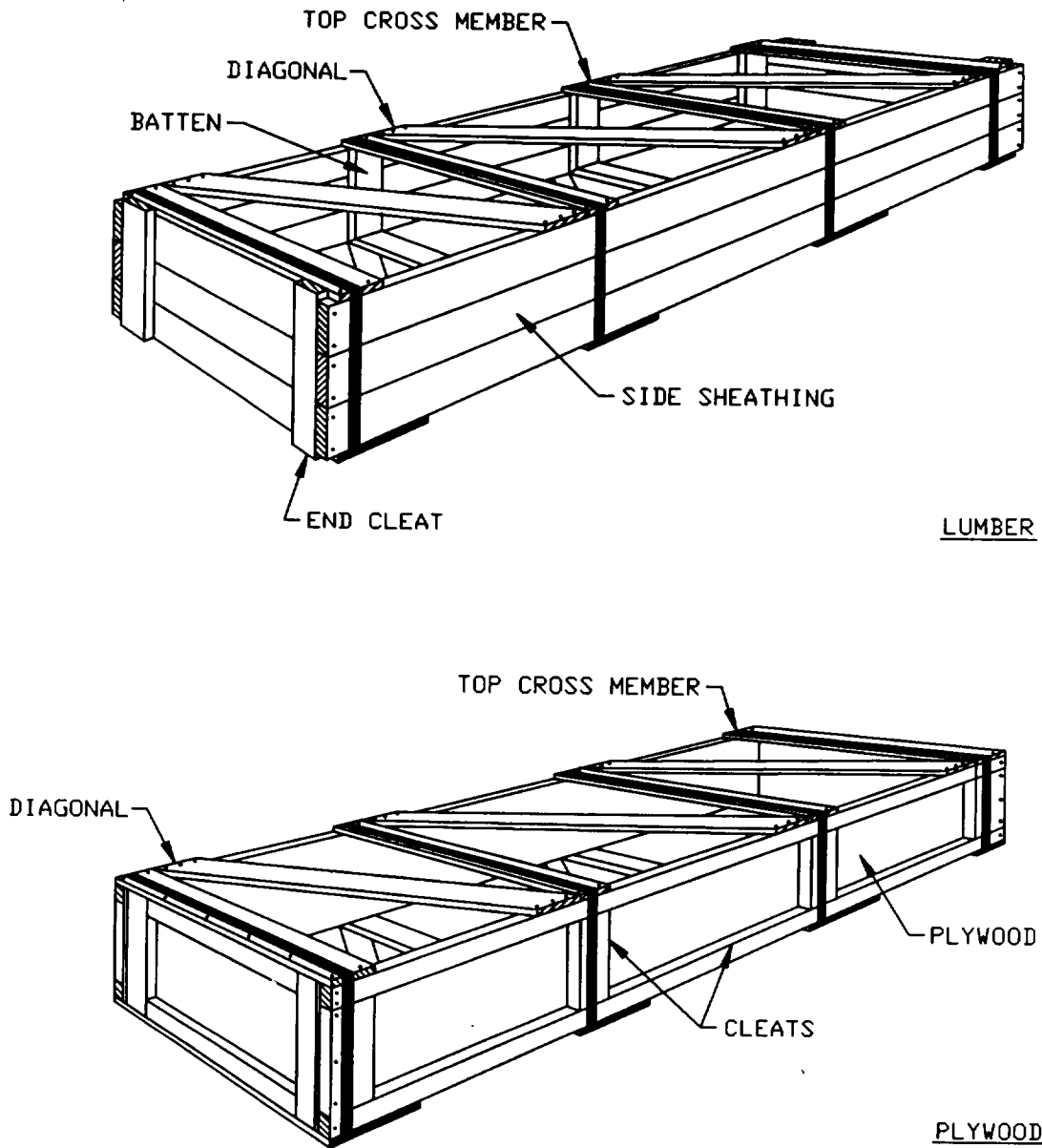
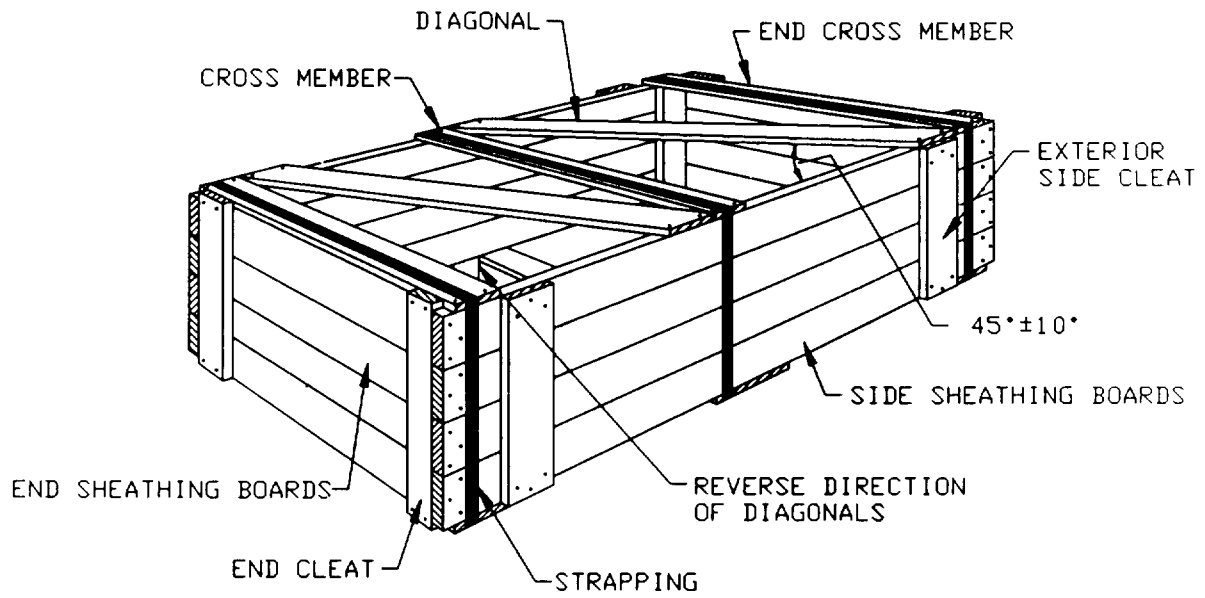
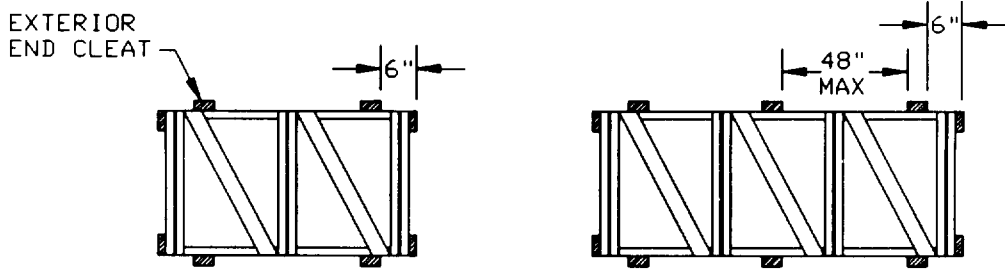

FIGURE 5. Type II, style A, crate assembly.



A



B

C

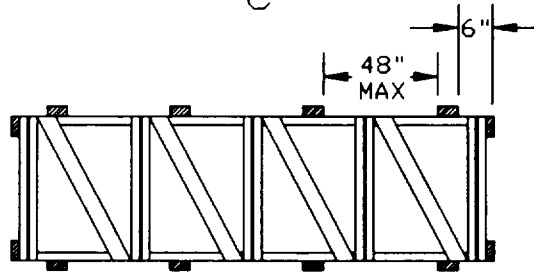

D

FIGURE 6. Type II, crate with exterior side cleats:
A, complete crate; B, two panel; C, three panel;
and D, four panel.

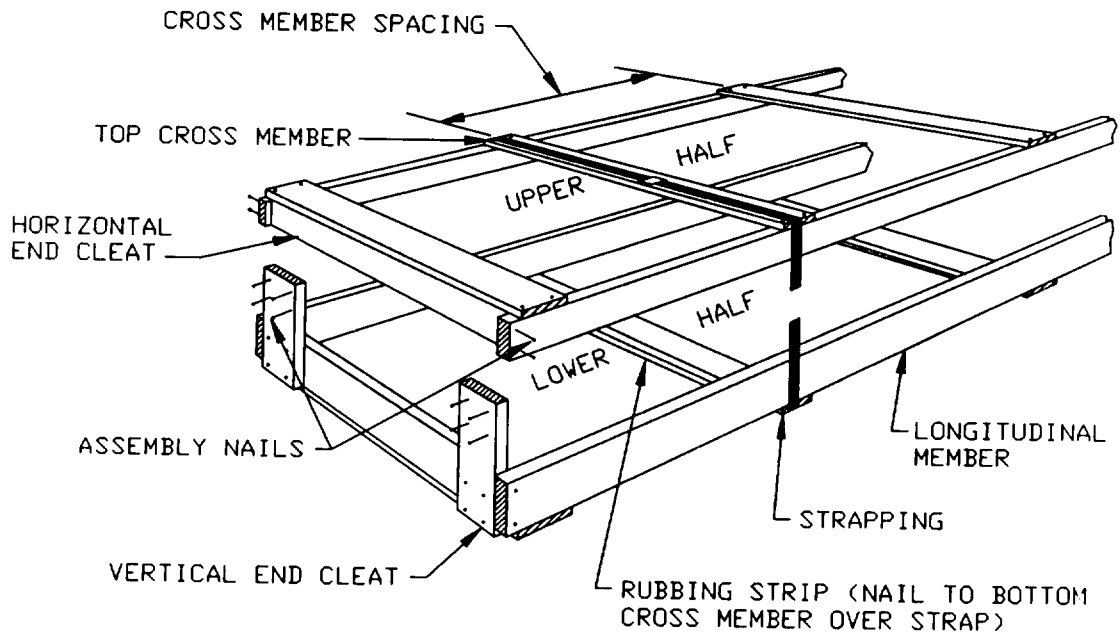

FIGURE 7. Type III, style B, crate assembly.

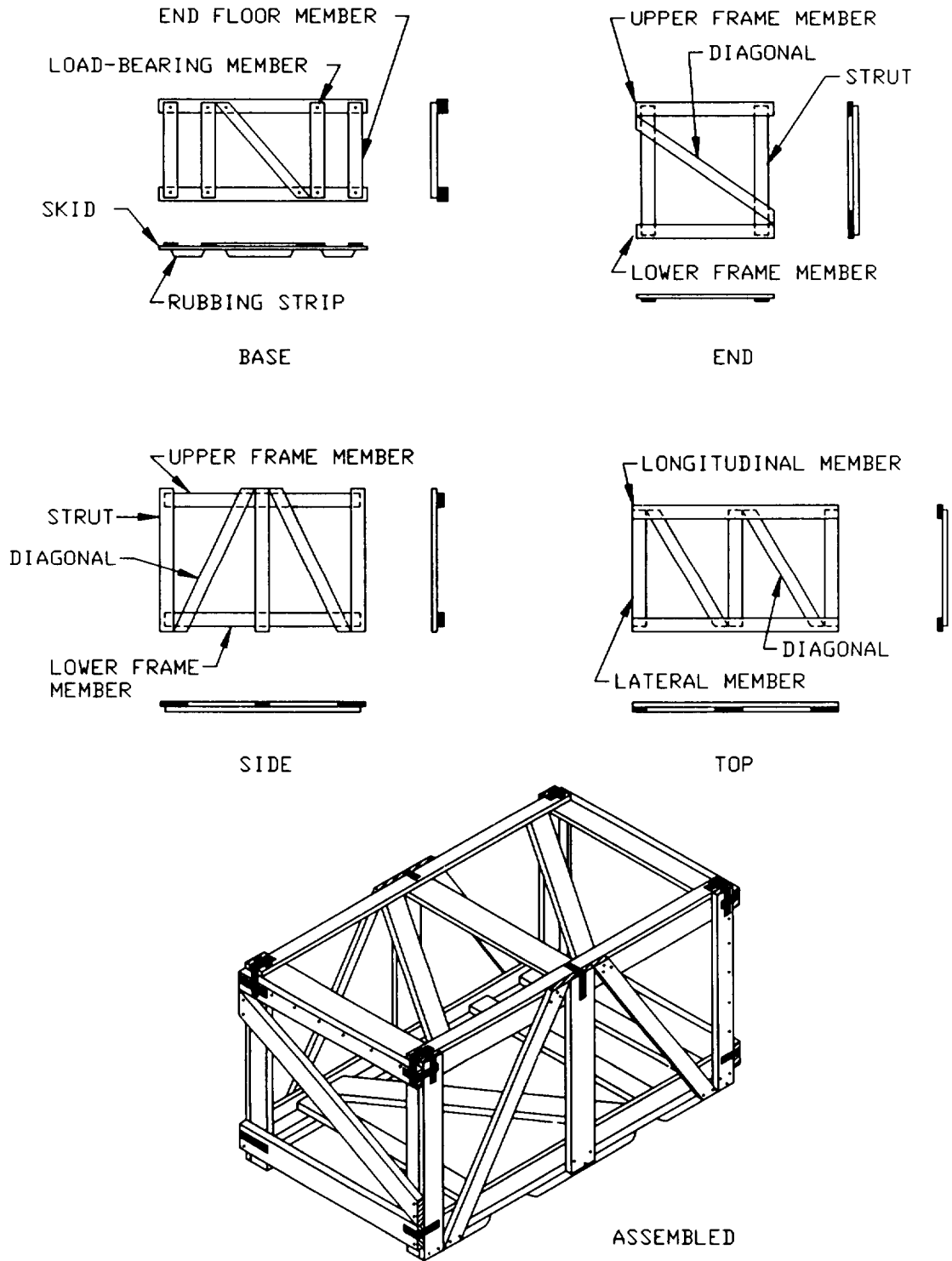

FIGURE 8. Type IV, style A crate assembly.

MIL-C-52950A

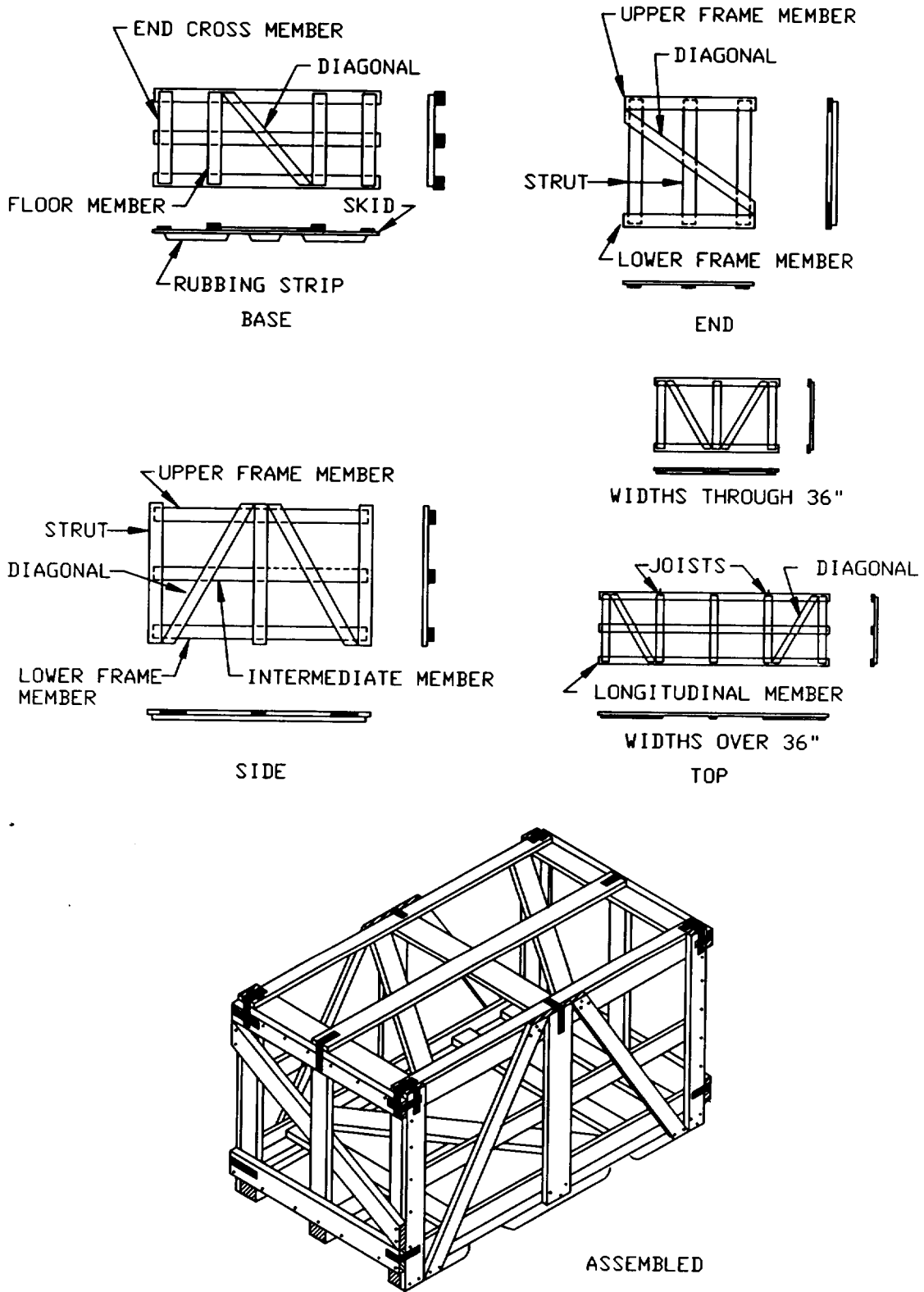
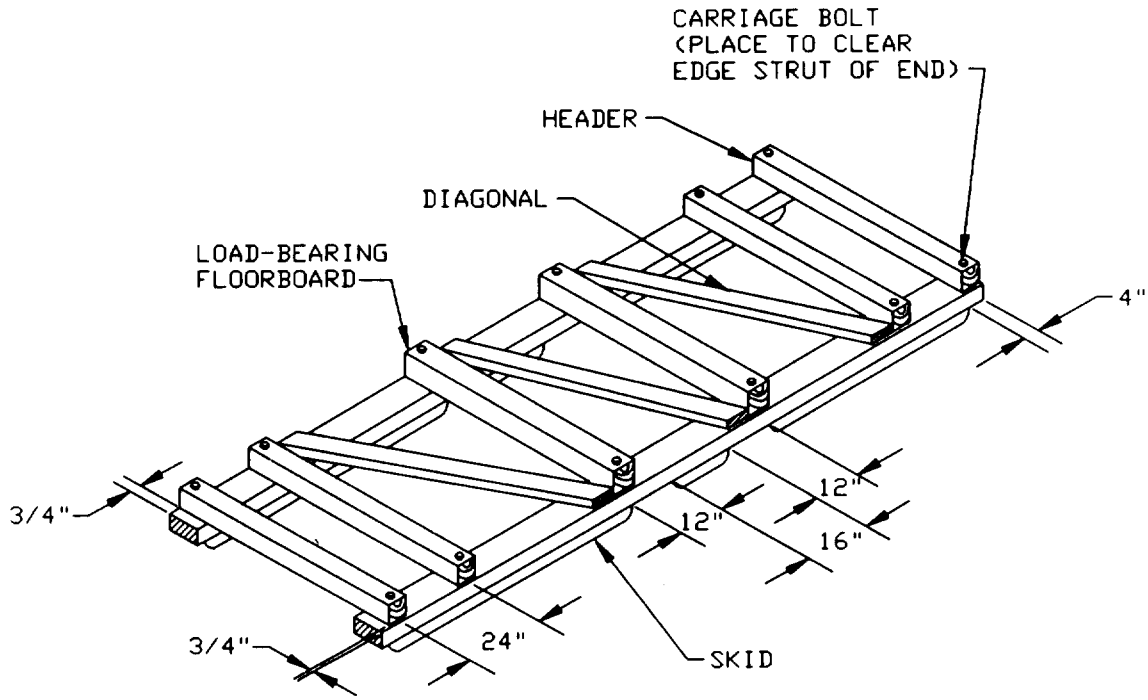
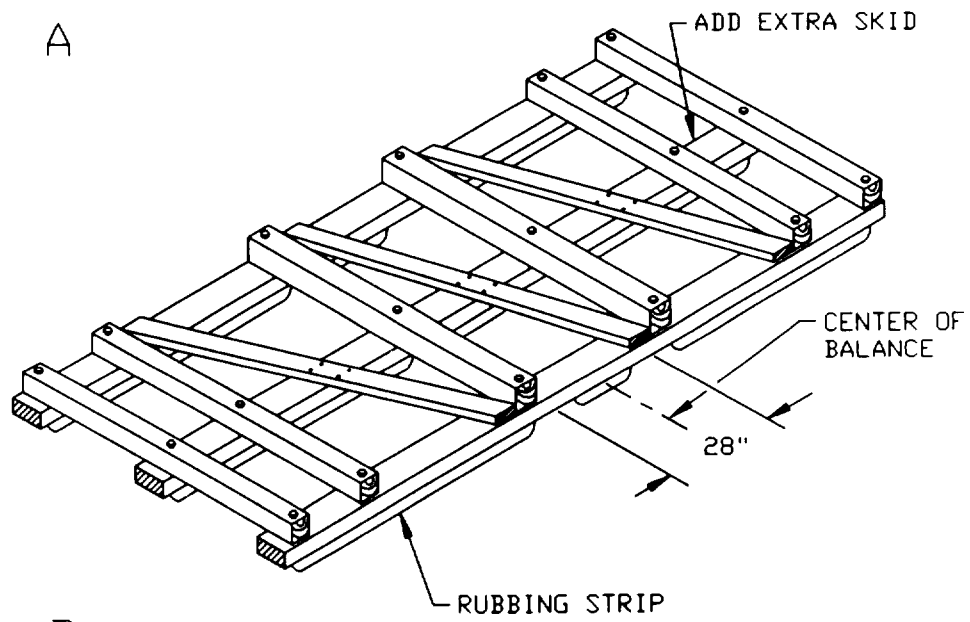

FIGURE 9. Type V, style A crate assembly.



A



B

FIGURE 10. Bases for type V, style B crates:
A, up through 42 inches wide;
B, over 42 inches wide.

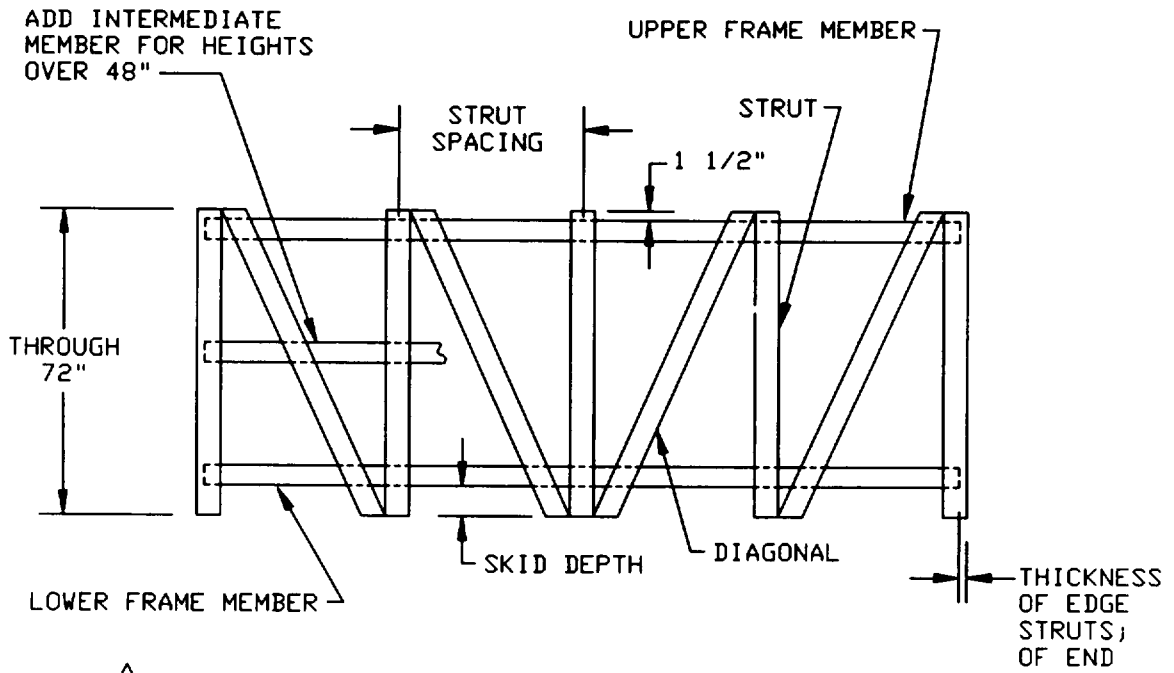

A

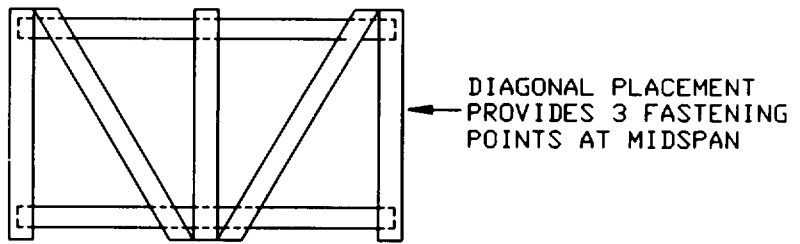

B

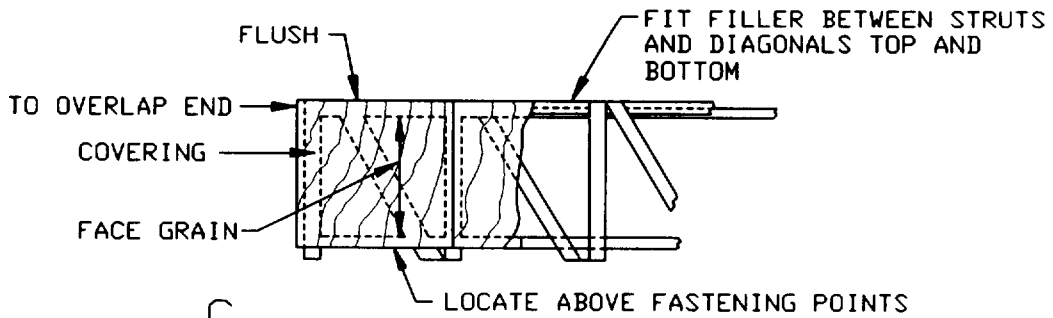

C

FIGURE 11. Single - panel sides for Type V, style B crates:
A, side of long crate; B, side of short crate;
C, covered side.

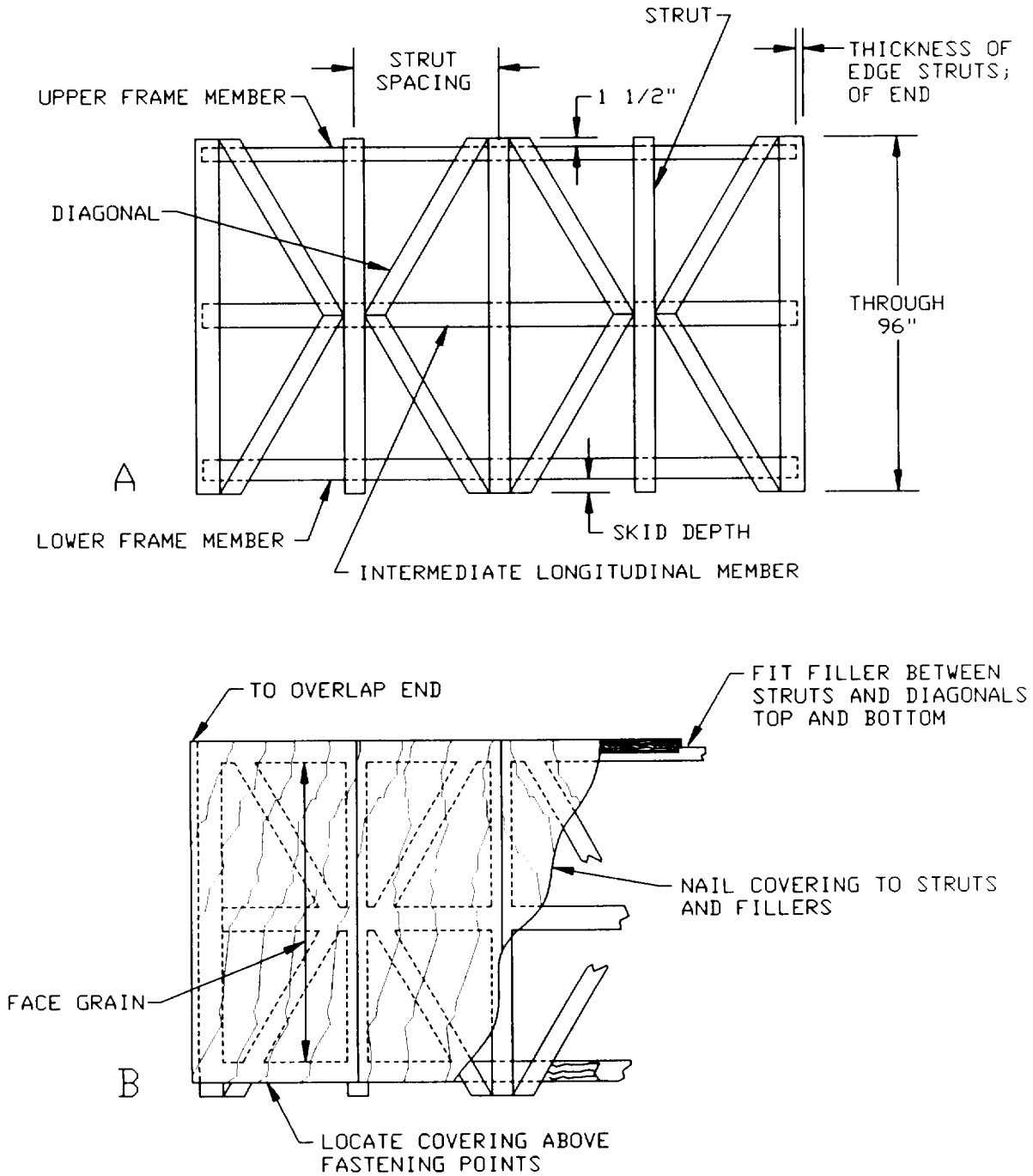

FIGURE 12. Double - panel sides for type V, style B crates
for heights through 96 inches; A, open side;
B, covered side.

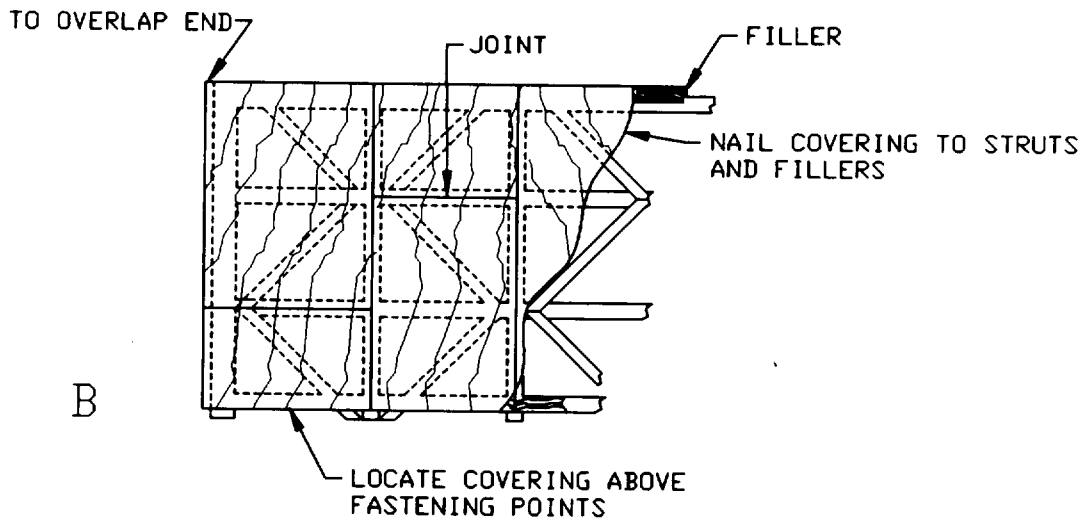
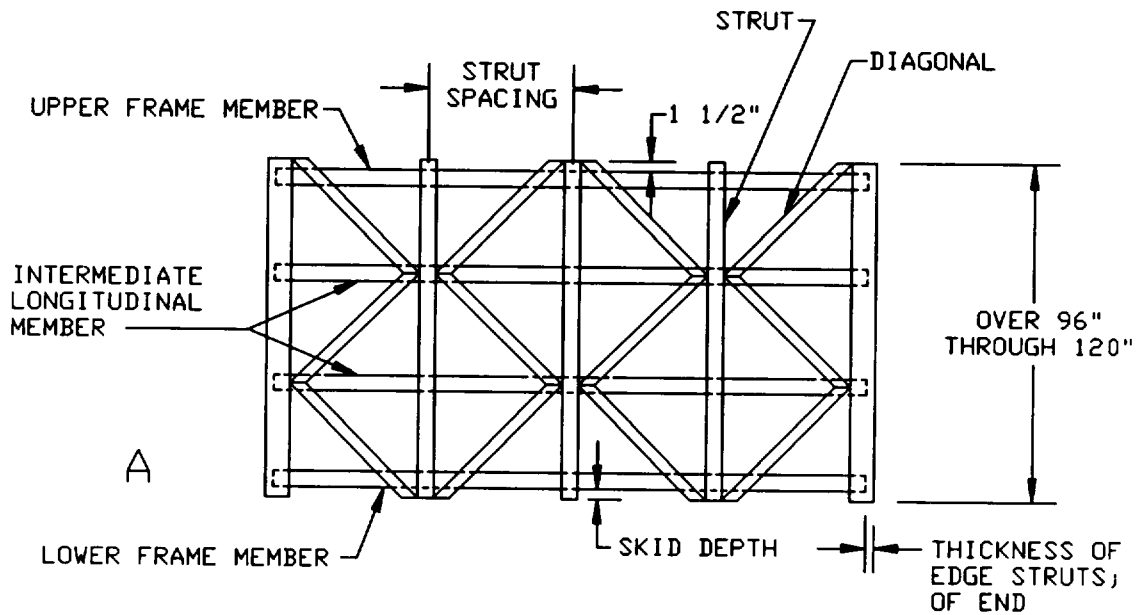

FIGURE 13. Triple - panel sides for type V, style B crates for heights over 96 inches: A, open side; B, covered side.

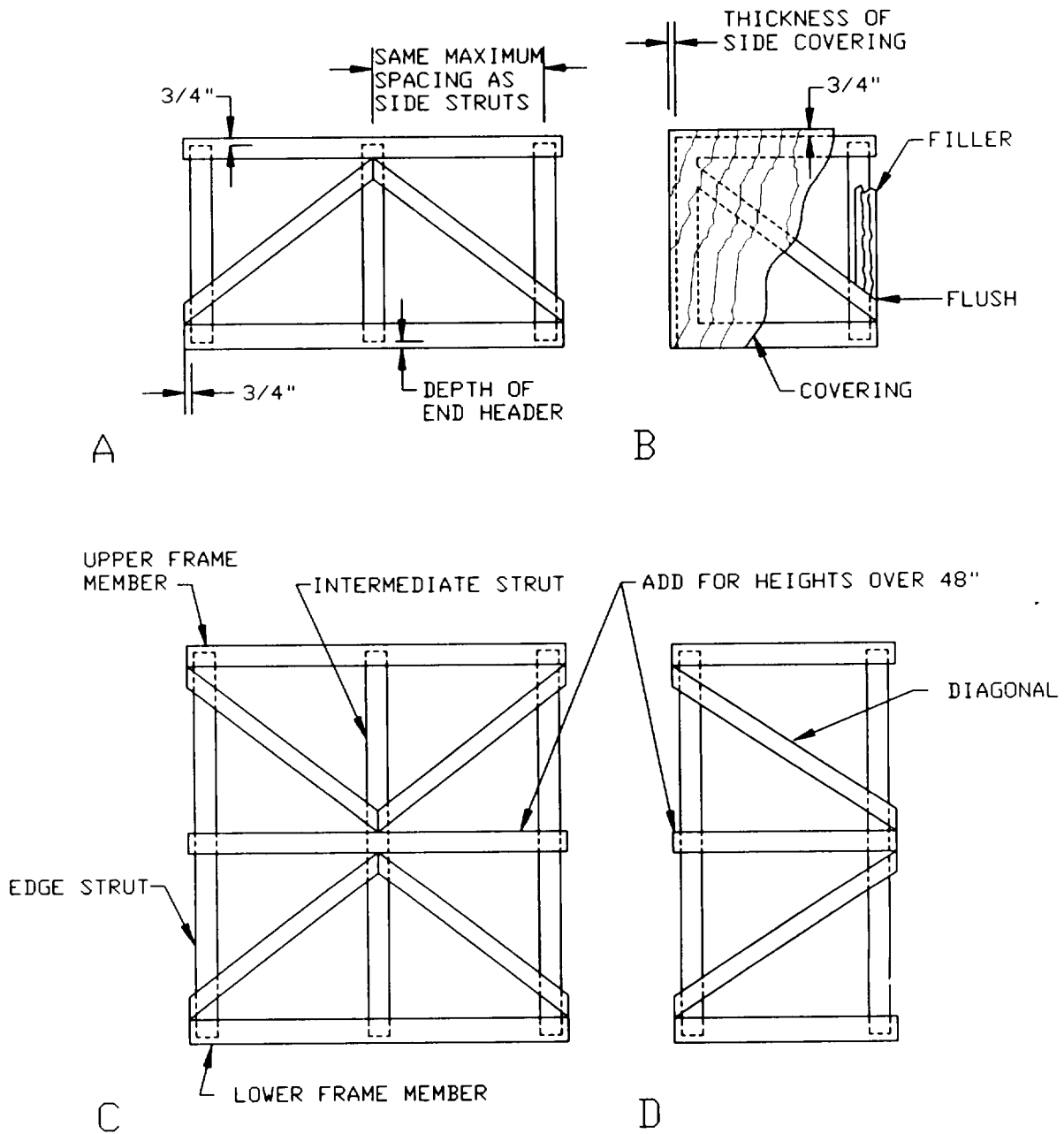

FIGURE 14. Ends for type V, style B crates: A, two - panel horizontal; B, single - panel (covered); C, four - panel; D, two - panel vertical.

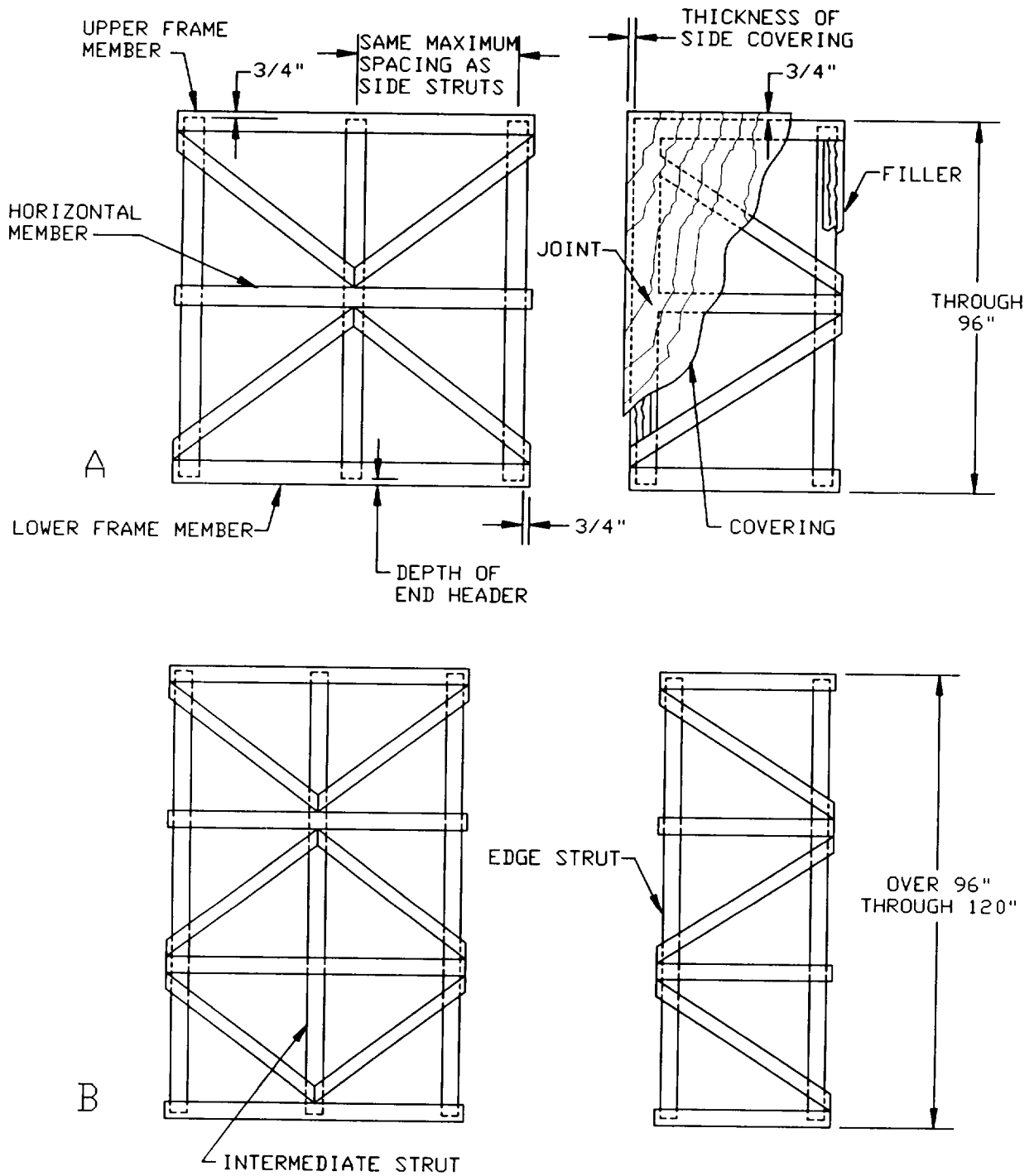

FIGURE 15. Ends for type V, style B crates: A, wide and narrow double - panel ends; B, wide and narrow triple - panel ends.

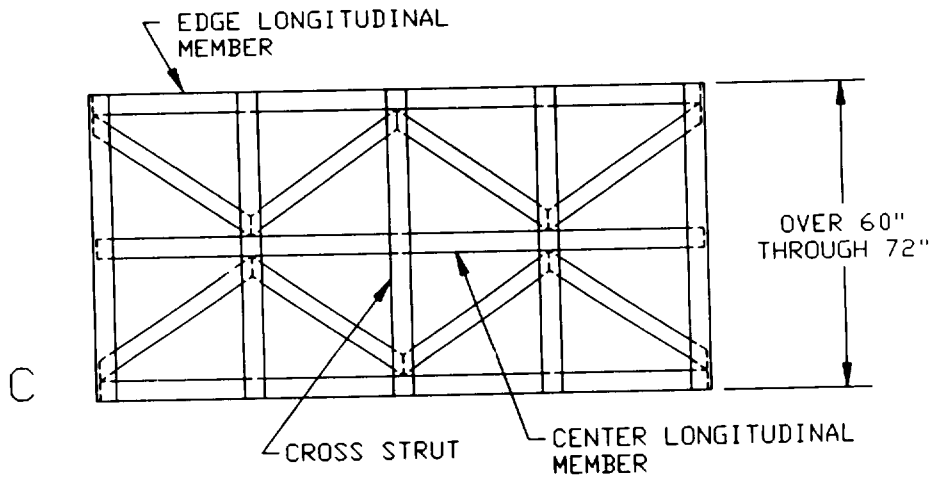
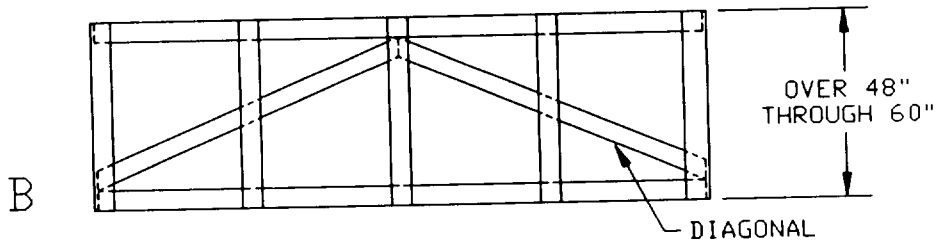
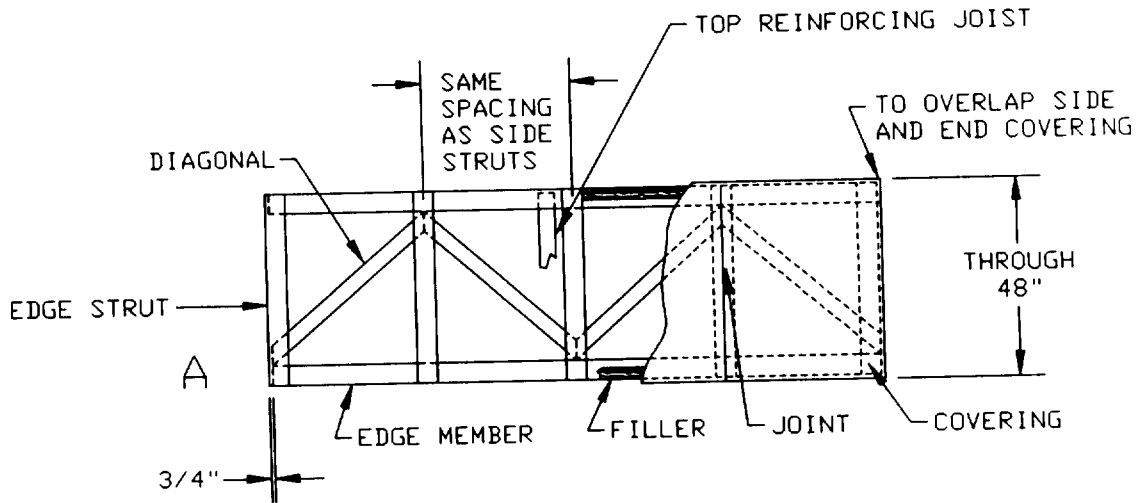

FIGURE 16. Tops for type V, style B crates:
A, narrow top; B, medium - wide top;
C, wide top.

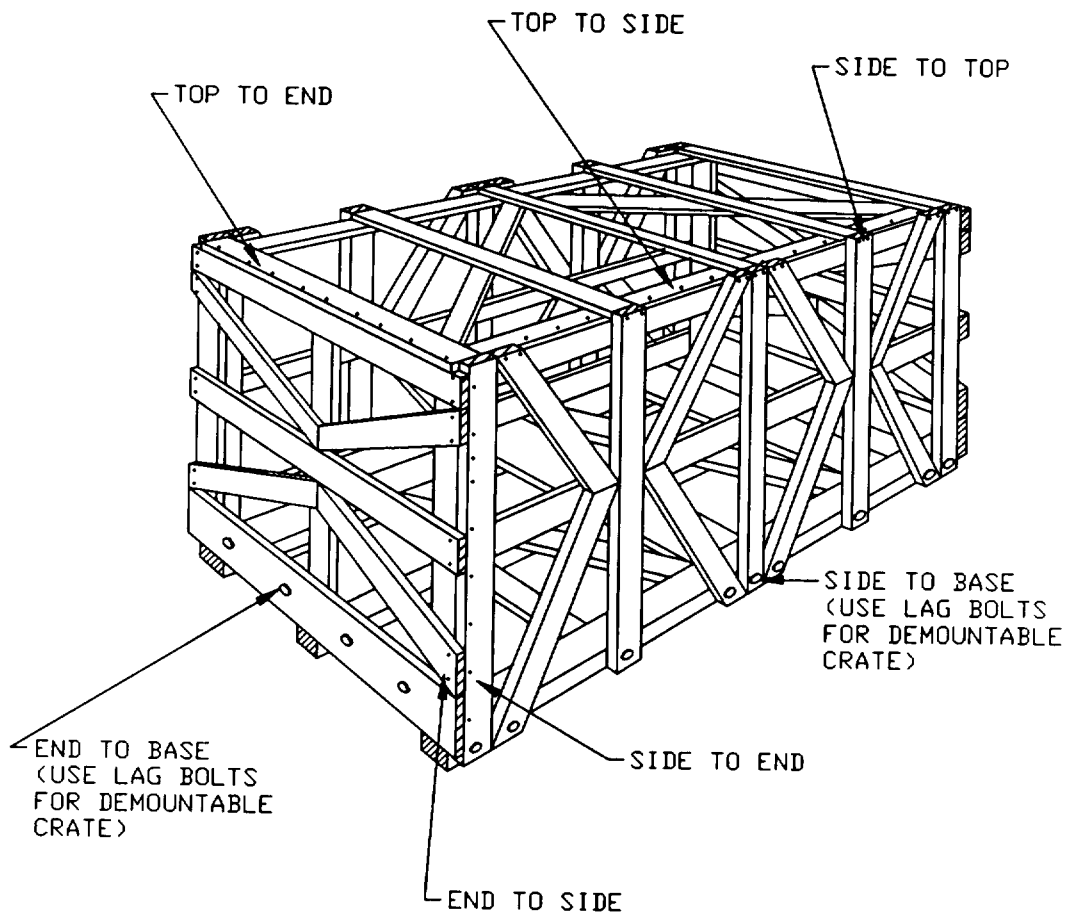

FIGURE 17. Type V, style B crate assembly (open).

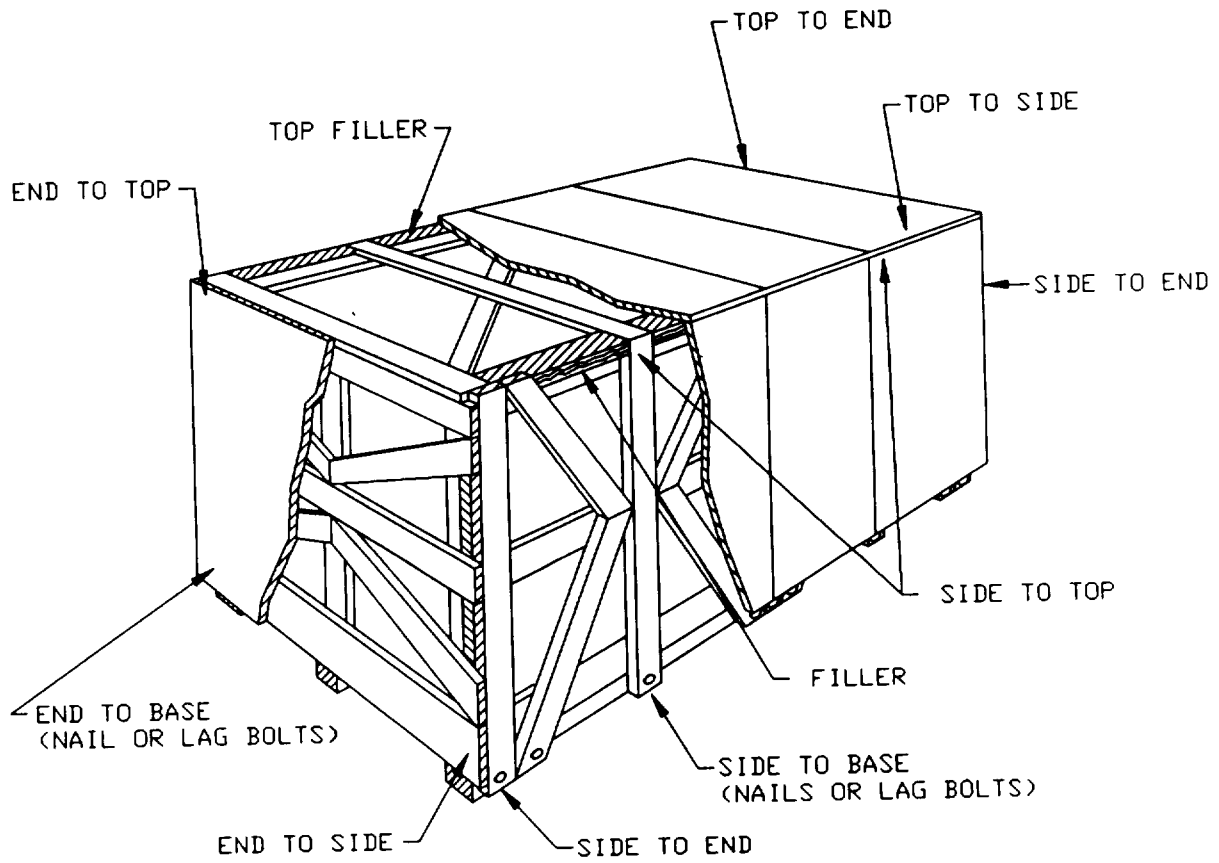

FIGURE 18. Type V, style B crate assembly (covered).