

MIL-B-26195C – Military Specification – Boxes, Wood Cleated, Skidded, Load-Bearing Base

Subject/Scope:

This specification covers the requirements for new wood boxes, wood-cleated with skidded load-bearing bases. Boxes covered herein are designed for all non hazardous domestic and overseas shipments of loads.

Keywords:

plywood, base, skid, box, requirement, type, load, bolt, cleat, panel, lag, inspection, box, lumber, specification, container, wood, nail, grade, members, nominal, ventilation, mil, support, joist, packaging, header, standard, document, fiberboard, marking, material, class, rubbing, joist, std, carriage, dimension, government, assembled, fastener, packing, shipping, military, fastener

Published:

5/15/1987

Text in blue boxes such as this one is instructional and is intended to assist you in understanding the document.

Text in red boxes such as this explains changes made to the document by The Wooden Crates Organization.

Red text has been added to the document or modifies the document since its final version was officially published.

Soft Conversion of Imperial to Metric

Conversions made consider materials that are available in metric or imperial sizes rather than converting sizes exactly. For example: Panelboard (plywood) in the US is typically 4 feet X 8 feet (1220 x 2440 mm) while panelboard in metric countries is typically 1200 X 2400 mm. Since the standard was developed based on readily available materials these variations in material sizes could not have been practically considered.



This document has been converted to allow for better understand and easier navigation between documents. Although this document may be retired by the original publisher, it may still be useful in understanding the subject matter.

If you identify any errors or inaccuracies in this document, please contact us at info@woodencrates.org

Efforts have been taken to preserve the credits of the original writer(s) when available.

Under Section 5 of the United States Copyright Act and in accordance with FAR 52.227-14 the original contents of this document is noncopyright. Modifications to this document are the property of The Wooden Crates Organization and this version of this document may not be modified without written permission of WoodenCRATES org, LLC.

© Copyright [WoodenCRATES org, LLC](http://WoodenCRATES.org), All Rights Reserved. May be distributed freely but not modified.

Table of Contents

| | |
|--|----|
| 1. SCOPE | 1 |
| 1.1..... | 1 |
| 1.1.1 Hazardous Materials Boxes | 1 |
| 1.2 Classification | 1 |
| 2. APPLICABLE DOCUMENTS | 2 |
| 2.1 Government documents | 2 |
| 2.1.1 Specifications, standards, and handbooks | 2 |
| 2.2 Other publications..... | 3 |
| 2.3 Order of precedence | 3 |
| 3. REQUIREMENTS | 3 |
| 3.1 Materials | 3 |
| 3.1.1 Lumber | 3 |
| 3.1.2 Plywood | 3 |
| 3.1.3 Fiberboard..... | 4 |
| 3.1.4 Paper-overlaid veneer | 4 |
| 3.1.5 Fasteners | 4 |
| 3.2 Base components | 4 |
| 3.2.1 Lumber-floored base..... | 7 |
| 3.2.2 Plywood base | 7 |
| 3.2.3 Headers | 7 |
| 3.2.4 Rubbing strips for skids..... | 7 |
| 3.2.5 Superstructure components | 8 |
| 3.3 Fabrication requirements | 8 |
| 3.3.1 Dimensions | 8 |
| 3.3.2 Base fabrication | 8 |
| 3.3.3 Superstructure fabrication..... | 9 |
| 3.4 Assembly requirements..... | 10 |
| 3.4.1 Assembly of superstructure panels..... | 10 |
| 3.4.2 Assembly of superstructure to base | 10 |
| 3.5 Ventilation..... | 11 |
| 3.5.1 Ventilation slots | 11 |

| | | |
|----------|--|----|
| 3.5.2 | Ventilation holes..... | 12 |
| 3.6 | Workmanship..... | 12 |
| 3.7 | Special markings | 12 |
| 3.8 | Fire retardant markings..... | 12 |
| 4. | QUALITY ASSURANCE PROVISIONS | 13 |
| 4.1 | Responsibility for inspection | 13 |
| 4.1.1 | Responsibility for compliance | 13 |
| 4.2 | Classification of inspections | 13 |
| 4.3 | Inspection conditions | 13 |
| 4.4 | End item inspection | 13 |
| 4.4.1 | Quality conformance inspection sampling..... | 13 |
| 4.4.2 | Examination of packaging | 15 |
| 4.4.3 | Inspection levels and AQLs for examinations..... | 15 |
| 5. | PACKAGING | 16 |
| 5.1 | Packing | 16 |
| 5.1.1 | Level C | 16 |
| 5.2 | Preservation | 16 |
| 5.3 | Marking for shipment..... | 16 |
| 6. | NOTES..... | 16 |
| 6.1 | Intended use..... | 16 |
| 6.2 | Ordering data | 16 |
| 6.3 | Metric conversions..... | 17 |
| 6.3.1 | | 20 |
| 6.4 | Subject term (key word) listing..... | 20 |
| 6.5 | Changes from previous issue..... | 20 |
| APPENDIX | | 30 |
| 10. | SCOPE | 30 |
| 10.1 | Scope | 30 |
| 20. | APPLICABLE DOCUMENTS | 30 |
| 20.1 | Government documents..... | 30 |
| 20.1.1 | Other government documents and publications..... | 30 |
| 20.2 | Non Government Publication | 30 |
| 20.3 | Order of precedence | 31 |

| | | |
|--------|--|----|
| 30. | REQUIREMENTS | 31 |
| 30.1 | Hazardous materials boxes | 31 |
| 30.2 | Test requirements | 31 |
| 30.2.1 | Rough handling (drop) test | 31 |
| 30.2.1 | Stacking test | 31 |
| 30.2.2 | Vibration test..... | 32 |
| 40. | PERFORMANCE REQUIREMENTS | 32 |
| 40.1 | Specimen preparation | 32 |
| 40.2 | Performance tests | 32 |
| 40.2.2 | Stacking test..... | 32 |
| 40.2.3 | Vibration test | 32 |
| 50. | TEST REPORTS | 33 |
| 50.1 | Hazardous material, boxes test reports | 33 |
| 60. | MARKINGS | 33 |
| 60.1 | Hazardous materials boxes | 33 |
| 70. | NOTES | 33 |
| 70.1 | Acquisition requirements | 33 |

MIL-B-26195C
15 May 1987
SUPERSEDING
MIL-B-26195B
26 July 1974

MILITARY SPECIFICATION

BOXES, WOOD-CLEATED, SKIDDED, LOAD-BEARING BASE

This specification is approved for use within the Department of Defense and is available for use by all Departments and Agencies of the Department of Defense.

1. SCOPE

1.1.

This specification covers the requirements for new wood boxes, wood-cleated with skidded load-bearing bases. Boxes covered herein are designed for all non hazardous domestic and overseas shipments of loads.

1.1.1 Hazardous Materials Boxes

Boxes up to a maximum net mass of 882 pounds and intended for shipment or storage of regulated hazardous materials must meet all the requirements of this specification including the requirements of this Appendix.

1.2 Classification

Boxes shall be of the following types, styles, and classes, as specified (see 6.2):

Type I — For Domestic Shipment
Type II — For Overseas Shipment

Style A — Regular Cleating Arrangement (see Figure 1) Style B — Lock Corner Cleating Arrangement (see Figure 1)

Class 1 — Plywood Base (see Figure 2)
Class 2 — Lumber Base (see Figure 2)

Grade I — Standard
Grade II — Fire Retardant

Beneficial comments (recommendations, additions, deletions) and any pertinent data which may be of use in improving this document should be addressed to: Air Force Packaging Evaluation Agency (HQ AFLC/DSTZ), Wright-Patterson AFB OH 454 33, by using the self-addressed Standardization Document Improvement Proposal (DD Form 1426) appearing at the end of this document or by letter.

AMSC N/A

FSC 8115

DISTRIBUTION STATEMENT A. Approved for public release; distribution is unlimited.

2. APPLICABLE DOCUMENTS

2.1 Government documents

2.1.1 Specifications, standards, and handbooks

The following specifications, standards, and handbooks form a part of this specification to the extent specified herein. Unless otherwise specified, the issues of these documents shall be those listed in the issue of the Department of Defense Index of Specifications and Standards (DODISS) and supplement thereto, cited in the solicitation.

SPECIFICATIONS

Federal

| | |
|---------------------------|---|
| FF-B-561 | Bolts, (Screw), Lag |
| FF-N-105 | Nails, Brads, Staples and Spikes: Wire, Cut and Wrought |
| FF-W-92 | Washer, Flat (Plain) |
| TT-W-572 | Wood Preservative: Water-Repellent |
| PPP-B-576 | Boxes, Wood, Cleated, Veneer, Paper Overlaid |
| PPP-B-591 | Boxes, Shipping, Fiberboard, Wood-Cleated |
| PPP-B-601 | Boxes, Wood, Cleated-Plywood |
| PPP-F-320 | Fiberboard: Corrugated and Solid, Sheet Stock (Container Grade), and Cut Shapes |
| PPP-V-205 | Veneer, Paper Overlaid, Container Grade |
| A-A-55057 | Panels, Wood/Wood Based; Construction and Decorative |
| FF-B-584 | Bolts, Square Neck and Tee Head |

Military

| | |
|-------------------------------|---|
| MIL-PRF-16173 | Corrosion Preventive Compound, Solvent Cutback, Cold-Application |
| MIL-L-19140 | Lumber and Plywood, Fire-Retardant Treated |
| MIL-S-46163 | Sealing, Lubricating and Wicking Compounds: Thread-Locking, Anaerobic, Single-Component |

STANDARDS

Military

| | |
|-----------------------------|---|
| MIL-STD-105 | Sampling Procedures and Tables for Inspection by Attributes |
| MIL-STD-129 | Marking for Shipment and Storage |
| MIL-STD-731 | Quality of Wood Members for Containers and Pallets |

(Copies of specifications and standards required by contractors in connection with specific acquisition functions should be obtained from the contracting activity or as directed by the contracting activity.)

U.S. Department of Commerce

| | |
|----------------------|-------------------------------------|
| PS 1 | Construction and Industrial Plywood |
|----------------------|-------------------------------------|

[\(Applications for copies should be addressed to the Superintendent of Documents, U.S. Government Printing Office, Washington D.C. 20402.\)](#)

2.2 Other publications

The following document form a part of this specification to the extent specified herein. Unless otherwise specified, the issues of the documents which are DOD adopted shall be those listed in the issue of the DODISS specified in the solicitation. Unless otherwise specified, the issues of documents not listed in the DODISS shall be the issue of the nongovernment documents which is current on the date of the solicitation.

[American National Standards Institute \(ANSI\)](#)

HPMA MP-1983 Hardwood and Decorative Plywood

[\(Applications for copies should be addressed to the American National Standards Institute, 1430 Broadway, New York NY 10018.\)](#)

[\(ASTM\)](#)

[ASTM D 3953](#) Standard Specification for Strapping, Flat Steel and Seals (DOD Adopted)
[ASTM E 380](#) Metric Practice

[\(Applications for copies should be addressed to the American Society for Testing and Materials, 1916 Race St., Philadelphia PA 19103.\)](#)

2.3 Order of precedence

In the event of a conflict between the text of this specification and the reference cited herein (except for associated detail specifications, specification sheets or MS standards), the text of this specification shall take precedence. Nothing in this specification, however, shall supersede applicable laws and regulations unless a specified exemption has been obtained.

3. REQUIREMENTS

3.1 Materials

When specified (see 6.2), materials shall be fire-retardant treated in accordance with [MIL-L-19140](#). Metric conversions of physical properties of materials are in accordance with ASTM E380 and shown in Table VII. (See 4.4.1).

3.1.1 Lumber

Lumber for all components shall conform to the requirements of [M1L-STD-731](#). Lumber for superstructure components shall conform to the requirements for cleated panel boxes and lumber for base components to those for crates. (See 4.4.1).

3.1.2 Plywood

Unless otherwise specified, plywood used in the fabrication of Type I boxes shall conform to ANSI/HPMA HP 198 3, Type II, Grade 3-4; or PS 1, interior, Grade C-D. Plywood used to fabricate Type II boxes shall conform to ANSI/HPMA HP 1983, Type I, Grade 3-4; PS 1, interior with exterior glue; or PS 1, exterior, Grade C-C. Minimum acceptable grade and type plywood shall conform to [A-A-55057](#) referenced commercial and product standards. (Plywood is furnished unsanded and untreated. The contract or purchase order should specify sanding or treatment if such is required (see 6.2). Water repellent conforming to [TT-W- 572](#) shall be used when treatment is specified.) (See 4.4.).

3.1.3 Fiberboard

Unless otherwise specified, fiberboard shall conform to [PPP-F-320](#). Type SF, class domestic, grade 4j or 600 shall be used in the fabrication of Type I boxes. Type SF, class weather-resistant, grade V2s, V3s, or V4s shall be used in the fabrication of Type II boxes. (See 4.4.).

3.1.4 Paper-overlaid veneer

Unless otherwise specified, paper-overlaid veneer for Type I and Type II boxes shall be in accordance with [PPP-V-205](#), Type I and Type II, respectively. (See 4.4.).

3.1.5 Fasteners

Nails and staples shall be steel and shall be in accordance with the applicable requirements of [FF-N-105](#). Unclinched nails shall be cement coated or chemically etched. Lag bolts shall be in accordance with the requirements of [FF-B-561](#). Carriage bolts shall be Type I, class I, style A with nuts in accordance with [FF-B-584](#). Washers for lag and carriage bolts shall conform to Type A, grade I, class A, black oxide coated of FF-W-92. (See 4.4.1).

3.1.5.1 Commercial parts

Unless otherwise specified, commercial parts may be substituted to the maximum extent, consistent with reliability, maintainability, and performance. Commercial utility parts with suitable properties, such as nails, staples, lag bolts, carriage boles and washers, may be used provided they can be replaced with standard parts (MS and AN) without alteration."

3.2 Base components

The base components are illustrated in Figure 2. Lumber used in the skids shall be in accordance with the requirements of 3.1.1, except that group I woods shall not be used. The dimensions of skids shall be as shown in Table I, and those with rectangular cross sections are intended to be used flat wise. For boxes whose outside width does not exceed 36 inches, 2 skids shall be required. When the outside width exceeds 36 inches, a third skid conforming to Table I shall be placed equidistant between and parallel with the outer skids. When specified (see 6.2), the lower one-third of the ends of each skid and the adjacent corner of the side panel shall be beveled 45 ± 5 degrees. Lumber used for load-bearing floor members shall be in accordance with the requirements of 3.1.1 and shall be selected in accordance with Table II. When the container width is 24 inches or less, the length 36-60 inches and height is 72 inches or greater, place skids crosswise (widthwise) rather than lengthwise and adjust the other base components accordingly (headers, base, etc.). (See 4.4.1).

TABLE I. Nominal Sizes 1/ and Maximum Lengths of Skids

| Weight of contents (pounds) | Load Condition 2/ | Nominal Sizes (Inches) 1/ | | | | | |
|-----------------------------|-------------------|-------------------------------|-------|-------|-------|-------|-------|
| | | 2 X 4 | 2 X 6 | 2 X 8 | 4 X 4 | 4 X 6 | 6 X 6 |
| | | Maximum Length of skid (feet) | | | | | |
| 0-100 | A | 16 | - | - | - | - | - |
| | B | 16 | - | - | - | - | - |
| | C | 16 | - | - | - | - | - |
| | D | 16 | - | - | - | - | - |
| | E | 16 | - | - | - | - | - |
| 101-200 | A | 16 | - | - | - | - | - |
| | B | 16 | - | - | - | - | - |
| | C | 16 | - | - | - | - | - |
| | D | 16 | - | - | - | - | - |
| | E | 16 | - | - | - | - | - |
| 201-400 | A | 11 | 15 | 16 | - | - | - |
| | B | 13 | 16 | - | - | - | - |
| | C | 8 | 12 | 16 | - | - | - |
| | D | 10 | 15 | 16 | - | - | - |
| | E | 13 | 16 | - | - | - | - |
| 401-600 | A | 8 | 11 | 14 | 16 | - | - |
| | B | 9 | 14 | 16 | - | - | - |
| | C | 5 | 8 | 11 | 16 | - | - |
| | D | 7 | 10 | 14 | 16 | - | - |
| | E | 9 | 14 | 16 | - | - | - |
| 601-800 | A | 7 | 9 | 11 | 16 | - | - |
| | B | 7 | 10 | 14 | 16 | - | - |
| | C | 4 | 6 | 8 | 16 | - | - |
| | D | 5 | 8 | 10 | 16 | - | - |
| | E | 7 | 10 | 14 | 16 | - | - |
| 801-1000 | A | 6 | 8 | 10 | 16 | - | - |
| | B | 5 | 8 | 11 | 16 | - | - |
| | C | 3 | 5 | 7 | 16 | - | - |
| | D | 4 | 6 | 8 | 16 | - | - |
| | E | 5 | 8 | 11 | 16 | - | - |
| 1001-1200 | A | 6 | 7 | 8 | 16 | - | - |
| | B | 4 | 7 | 9 | 16 | - | - |
| | C | 3 | 4 | 5 | 13 | 16 | - |
| | D | 3 | 5 | 7 | 16 | - | - |
| | E | 4 | 7 | 9 | 16 | - | - |
| Weight of contents (pounds) | Load Condition 2/ | Nominal Sizes (Inches) 1/ | | | | | |
| | | 2 X 4 | 2 X 6 | 2 X 8 | 4 X 4 | 4 X 6 | 6 X 6 |
| | | Maximum Length of skid (feet) | | | | | |
| 1201-1400 | A | 5 | 7 | 8 | 14 | 16 | - |
| | B | 5 | 6 | 8 | 16 | - | - |
| | C | 0 | 4 | 5 | 11 | 16 | - |
| | D | 3 | 4 | 6 | 14 | 16 | - |
| | E | 5 | 6 | 8 | 16 | - | - |
| 1401-1600 | A | 5 | 6 | 7 | 13 | 16 | - |
| | B | 3 | 5 | 7 | 16 | - | - |
| | C | 0 | 3 | 4 | 18 | 15 | 16 |
| | D | 3 | 4 | 5 | 12 | 16 | - |

Military Specification – Boxes, Wood-Cleated, Skidded, Load-Bearing Base

| | | | | | | | |
|-----------|---|---|---|---|----|----|----|
| | E | 3 | 5 | 7 | 16 | - | - |
| 1601-1800 | A | 5 | 6 | 7 | 12 | 16 | - |
| | B | 3 | 5 | 6 | 15 | 16 | - |
| | C | 0 | 3 | 4 | 9 | 14 | 16 |
| | D | 0 | 3 | 4 | 11 | 16 | - |
| | E | 3 | 5 | 6 | 15 | 16 | - |
| 1801-2000 | A | 4 | 5 | 6 | 11 | 15 | 16 |
| | B | 3 | 4 | 5 | 13 | 16 | - |
| | C | 0 | 0 | 3 | 8 | 12 | 16 |
| | D | 0 | 3 | 4 | 10 | 15 | 16 |
| | E | 3 | 4 | 5 | 13 | 16 | - |
| 2001-2200 | A | 4 | 5 | 6 | 10 | 14 | 16 |
| | B | 0 | 4 | 5 | 12 | 16 | - |
| | C | 0 | 0 | 3 | 7 | 11 | 16 |
| | D | 0 | 3 | 4 | 9 | 14 | 16 |
| | E | 0 | 4 | 5 | 12 | 16 | - |
| 2201-2400 | A | 4 | 5 | 6 | 10 | 13 | 16 |
| | B | 0 | 3 | 4 | 11 | 16 | 16 |
| | C | 0 | 0 | 3 | 7 | 10 | 16 |
| | D | 0 | 3 | 3 | 8 | 13 | 16 |
| | E | 0 | 3 | 4 | 11 | 16 | - |
| 2401-2500 | A | 4 | 5 | 6 | 9 | 13 | 16 |
| | B | 0 | 3 | 4 | 10 | 16 | - |
| | C | 0 | 0 | 3 | 6 | 10 | 16 |
| | D | 0 | 0 | 3 | 8 | 12 | 16 |
| | E | 0 | 3 | 4 | 10 | 16 | - |

1/ See 6.3.1 for definition

2/ The load condition is determined by the manner in which the load is applied to the skids (see Figures 3 and 4).

TABLE II. Allowable load (pounds) per inch of width of load-bearing floor members

| Length between outside skids (inches) | Nominal 1/1-inch thick boards (lbs per inch) | | Nominal 1/ 2-inch thick boards (lbs per inch) | | Nominal 1/ 3-inch thick boards (lbs per inch) | |
|---------------------------------------|--|-----------|---|-----------|---|-----------|
| | Wood Groups | | Wood Groups | | Wood Groups | |
| | I or II | III or IV | I or II | III or IV | I or II | III or IV |
| 12 | 38 | 46 | 176 | 211 | 459 | 551 |
| 18 | 26 | 31 | 118 | 142 | 306 | 367 |
| 24 | 19 | 23 | 88 | 106 | 230 | 276 |
| 30 | 15 | 18 | 70 | 84 | 183 | 220 |
| 36 | 13 | 16 | 58 | 70 | 154 | 185 |
| 42 | 11 | 13 | 52 | 62 | 131 | 157 |
| 48 | 10 | 12 | 44 | 53 | 115 | 138 |
| 54 | 9 | 11 | 39 | 47 | 102 | 122 |
| 60 | 7 | 8 | 35 | 42 | 92 | 110 |

1/ See 6.3.1 for definition

3.2.1 Lumber-floored base

Lumber used for floorboards shall be as specified in 3.1.1. Floorboards shall not be less than 1 inch (nominal) thick nor less than 4 inches (nominal) wide. (See 4.4.1)

3.2.2 Plywood base

Plywood base shall be in accordance with 3.1.2. The minimum thickness of the plywood shall be 3/8 inch. (See 4.4.1)

3.2.3 Headers

End headers shall be placed at the ends of all bases. They shall be of nominal size lumber conforming to 3.1.1 and shall be unspliced. When the container width is 36 inches or less, 2x4 inch headers shall be used. When container width exceeds

3.2.4 Rubbing strips for skids

Unless otherwise specified (see 6.2), rubbing strips of 3 inches (-1/8 inch) thickness shall be applied to skids to facilitate forklift entry. Rubbing strips shall be applied with two staggered rows of thirty penny nails spaced 12 inches apart in each row with a minimum of 5 nails required for each rubbing strip. When rubbing strips are used, the skids shall not be beveled. All rubbing strip ends shall be half beveled at 4 5+5 degrees and set back from ends of skids a distance of 2-1/2 to 4 inches to allow for sling placement. Openings for forklift access shall be a minimum 12 inches wide, 28 inches center to center, and positioned to straddle the center of gravity of the loaded container. The center pieces of rubbing strips shall be 16 inches in length. On short crates (less than 60 inches in length), forklift openings may be substituted for sling openings. (See 4.4.1).

3.2.5 Superstructure components

The sides, tops, and ends shall be of cleated panel construction. Panels shall be plywood, fiberboard or paper overlaid veneer as specified (see 6.2) and shall meet the material requirements of 3.1.2, 3.1.3, or 3.1.4, respectively. The sizes of the components for the cleated plywood, cleated fiberboard, and cleated paper-overlaid veneer superstructures shall comply with the applicable requirements of PPP-B-601, PPP-B-591, and PPP-B-576, respectively. The maximum size components given in those specifications shall be used for net weights in excess of 1,000 pounds. Cleating shall be external only. (See 4.4.1).

3.2.5.1 Cleats

Cleat arrangement on top, side and end panels (see Figure I) as well as filler cleat tolerance and drainage provisions shall be in accordance with PPP-B-601. (See 4.4.1).

3.2.5.2 Joists

Unless otherwise specified (see 6.2), joists shall be provided for all boxes in excess of 36 inches long and 24 inches wide. Lumber used for joists shall be in accordance with the requirements of 3.1.1. Joists shall be applied with their narrow surfaces in contact with the panel of the top and shall be spaced equal distances apart along the length of the box, but not to exceed 24 inches apart (center to center). The sizes of the joists shall be in accordance with Table III. When joists are required, they shall be supported vertically by supports which shall be in accordance with the provisions of 3.3.3.1.2 and laterally by supports which shall be in accordance with 3.3.3.1.3. (See 4.4.1)

TABLE III. Selection of Joists

| Nominal Joist Size (Inches) | Outside Width of Box (Inches) |
|--|--|
| None Required | 24 |
| 1 X 4 | 25-36 |
| 2 X 4 | 37-60 |

3.3 Fabrication requirements

Nominal dimensions shall be as specified in 5.1 of MIL-STD-731. (See 4.4.1)

3.3.1 Dimensions

Dimensions shall be specified by length, width, and height (see 6.2). Inside dimensions shall specify the inside length from the inside of the end panels (outside edge of headers); the inside width shall be equal to the width of the base (outside of outer skids); and the inside height shall be measured from the top of base/flooring to the bottom of the top panel. (See 4.4.1)

3.3.2 Base fabrication

3.3.2.1 Plywood flooring to skids

The plywood may be the full length and width of the container base or it may be a centrally located square piece with each side equal to the base width as illustrated in Figure 2. Plywood flooring shall be oriented so that the grain directions of face plies are perpendicular to skid length. If more than 1 plywood panel is used, a spacing of 1/4 inch shall be left between panels for drainage. Nailing of the plywood to the skids shall be as illustrated in Figure 5. Side edges of all plywood flooring shall be flush with the outer edges of the outside skids. When the plywood flooring is the full length of the base, end headers and load-bearing floor members shall be placed on top of the plywood and bolted to the skids. A drainage hole 1/2 inch in diameter shall be drilled in each corner of full length plywood bases. An additional drainage hole shall be placed along the sides of the plywood base for each 3 feet of *±he* inside length. (See figure 6). When load-bearing floor members are placed over plywood bases, at least one drainage hole shall be placed on each side of the plywood base between the load-bearing floor members. (See 4.4.1)

3.3.2.2 Lumber flooring to skids

Nailing of lumber flooring to the skids shall be as illustrated in Figure 5. Lumber shall be laid at right angles to the skids. The edges of adjacent boards shall be separated 1/8 to 1/4 inch to allow for swelling and drainage. The ends of boards shall be flush with the outer edges of the skids. (See 4.4.1)

3.3.2.3 Load-bearing floor members to skids

Load-bearing floor members over 2 inches thick and up to 4 inches in width shall be bolted to each skid with one carriage bolt. Load-bearing floor members over 2 inches thick and over 4 inches wide shall be bolted to each skid with 2 carriage bolts. The load-bearing floor members shall be fastened to the skids with 3/8 inch carriage bolts. Bolt holes shall be of the same diameter as the shank of the bolt. Plain washers in accordance with 3.1.5 shall be placed under the nuts of all bolts. After tightening, nuts shall be prevented from turning by the application of a thread locking compound in accordance with [MIL-S-46163](#). Load-bearing members less than 2 inches in thickness shall be nailed to the skids. Nails shall be as large as possible without splitting the piece. The load-bearing floor members shall be flush with the outer edges of the skids. (See 4.4.1)

3.3.2.4 End headers to skids

End headers in accordance with 3.2.3 shall be fastened to the skids with 3/8 inch carriage bolts. Headers shall be placed back from the ends of the skids a distance equal to the thickness of the end panels as illustrated in Figure 2, and shall be flush with the outer edges of the skids as illustrated in Figure 6. When plywood is used full length of the base, headers shall be placed on the plywood. (See 4.4.1)

3.3.3 Superstructure fabrication

Except as noted in 3.2.5.1 and 3.3.3.1, fabrication of cleated plywood, cleated fiberboard, and cleated paper-overlaid veneer panels, which form the superstructure, shall conform to the applicable requirements of PPP-B-601, PPP-B-591, and PPP-B-576, respectively. (See 4.4.1).

3.3.3.1 Fabrication of side panel

3.3.3.1.1 Joist supports

When top bracing joists are used, vertical and lateral joist supports shall be affixed to the side panels as illustrated in figure 7. The vertical and lateral supports shall conform to the material requirements for cleat stock except that the thickness shall not be less than 1 inch nominal for container loads up to 1,000 pounds and not less than 2 inch nominal for loads in excess of 1,000 pounds. (See 4.4.1).

3.3.3.1.2 Vertical joist supports

The vertical joist supports shall be fastened to the side panels with nails spaced not greater than 3 inches on centers (see Figure 7). The nails shall be staggered as shown. Nails shall be of sufficient length to pass through the joist support, the panel, the intermediate cleat of the side panel when matching occurs, and permit a clinch of not less than 1/8 inch when group II, III, or IV woods are used and 1/4 inch when group I woods are used. The supports shall be of sufficient length to extend from the under surface of the joist to the upper surface of the base decking or floor boards. (See 4.4.1).

3.3.3.1.3 Lateral joist supports

The lateral joist supports shall be fastened to the side panels with not less than two nails. Nails shall be of sufficient length to pass through the support block, the panel, the longitudinal cleat of the side panel, and permit a clinch of not less than 1/8 inch when group II, III, or IV woods are used and 1/4 inch when group I woods are used. These support blocks shall not be less than 3-1/2 inches long. (See 4.4.1)

3.4 Assembly requirements

3.4.1 Assembly of superstructure panels

Assembly of cleated plywood, cleated fiberboard, and cleated paper-overlaid veneer superstructures shall comply with the applicable requirements of PPP-B-601, PPP-B-591, and PPP-B-576, respectively. (See 4.4.1)

3.4.2 Assembly of superstructure to base

The end and side panels shall be assembled to the base with lag bolts specified in 3.1.5 and as illustrated in Figure 6. Side panels shall not extend below the bottom of the skids. When specified, boxes may be furnished assembled (see 6.2). (See 4.4.1)

3.4.2.1 Side to skid

A lag bolt shall be placed through each end of the lower longitudinal cleat of the side panel and into the skid at a distance of not less than 2 nor more than 3 inches from the end of the cleat. Additional lag bolts shall be equally spaced between the two end bolts with no distance exceeding 12 inches on crates 60 inches or greater in length and 18 inches on crates 60 inches or less." (See 4.4.1)

3.4.2.2 End to header

A lag bolt shall be placed through each end of the lower filler cleat and into the end header at a distance not less than 2 inches nor more than 3 inches from the end of the filler cleat. Additional lag bolts shall be equally spaced between the end bolts with no distance exceeding 12 inches. A minimum of two lag bolts are required through each end filler cleat. (See 4.4.1).

3.4.2.3 Size and placement of lag bolts

Lag bolts shall be 3/8 inch in diameter and 3 inches in length. Entry holes for lag bolts shall be 3/8 inch in diameter. Lead holes shall be 1/4 inch in diameter for group I, II, and III woods and 5/16 inch in diameter for group IV woods (see Figure 6). The combined depth of the entry and lead holes shall equal the total length of the shank and threaded portions. Lag bolts shall be turned in their holes the full distance. They shall not be driven by hammer. If the threads in the lead holes become stripped, the lag bolt shall be removed and placed in a new hole near the old position. A washer in accordance with 3.1.5 shall be placed under the head of each lag bolt. Countersinking for lag bolts shall not be permitted. (See 4.4.1).

3.4.2.4 Corner straps

When specified (see 6.2), corner straps shall conform to ASTM D3 953, Type 1 or 2, regular duty. Finish A, not less than 3/4 inch wide by 0.020 inch thick .by 12 inches in length. Corner strapping shall be prepunched or drilled with 1/8 inch holes at 1 inch intervals. Nails shall conform to FF-N-105, Type II, Style 19 or 20, blued or galvanized finish. Length of the nails shall be 7/8 to 1-1/8 inches. A minimum of three nails shall be used for each strap leg and strapping shall be located so that nailing is in a cleat. When intermediate cleats are required on the sides and top or on the ends, an additional strap shall be placed over each intermediate cleat. See Figure 8 for placement of straps. (See 4.4.1).

3.5 Ventilation

When specified (see 6.2), boxes shall be provided with ventilating holes or slots which shall be located at each end, or at ends and sides or around the perimeter of the box. These ventilating holes or slots shall be located immediately below the top cleats and be provided with a baffle located on the inside of the box as shown in Figure 9 for each ventilating area. In boxes over 10 feet in length, the ventilation area shall be divided equally between the sides and ends of the box, and each of these areas must have a baffle. The ventilating area on the ends shall be placed as near the midpoint as practical. On the sides, the ventilation area will be placed as near the center between the intermediate and edge vertical cleats as practical. Single holes do not require baffles but, shall be sloped at 45 degrees to drain outward. No holes or slots shall be cut in any cleat. (See 4.4.1).

3.5.1 Ventilation slots

When required (see 6.2), the ventilation slots shall be provided with baffles and screens as shown in Figure 9. The required ventilating area shall comply with Table IV. In small boxes, 3/4-inch-diameter holes may be substituted for the slots in the proportion of two holes for each square inch of required area. (See 4.4.1).

3.5.2 Ventilation holes

When required (see 6.2), boxes shall be provided with ventilating holes, 3/4 inch in diameter. All splinters and chips shall be removed from the holes. Ventilation holes shall be provided in each end in one or more clusters, placed near the upper cleats, provided with a baffle, and spaced 2 inches on center as shown in Figure 9. As an alternative to end ventilation, the ventilating holes may be spaced evenly around the perimeter of the crate just under the top cleats and drilled at a 45 degree angle to drain outward. The total number of holes shall comply with Table IV. (See 4.4.1).

TABLE IV Ventilation hole requirements

| Volume of box (cu. ft.) | End ventilation minimum number of 3/4 inch diameter holes required in each end (place in clusters and use baffle) | Perimeter ventilation (alternate) Total minimum number of 3/4 inch diameter holes required around perimeter (space evenly and slope to drain out) | Area required in each end (use baffle and screen) (sq. in.) |
|------------------------------------|--|--|--|
| 0-100 | 3 | 6 | 7 |
| 100-150 | 4 | 8 | 10 |
| 150-200 | 5 | 10 | 14 |
| 200-400 | 9 | 18 | 27 |
| 400-600 | 14 | 27 | 40 |

3.6 Workmanship

All boxes and components shall be free from imperfections which may affect their utility. Boxes shall be free from defects which will result in damage to the contents. (See 4.4.1).

3.7 Special markings

The following marking in minimum 1 inch high letters shall be placed on the ends and side panels of the boxes (see 4.4.1):

CAUTION: LIFT BY BASE ONLY _____

TO OPEN REMOVE BOTTOM LAG BOLTS _____ 1 inch

3.8 Fire retardant markings

When fire retardant boxes are specified, the words 'FIRE RETARDANT' shall be marked, in minimum 1-inch high letters, on two sides of the box."

4. QUALITY ASSURANCE PROVISIONS

4.1 Responsibility for inspection

Unless otherwise specified in the contract or purchase order, the contractor is responsible for the performance of all inspection requirements as specified herein. Except as otherwise specified in the contract or purchase order, the supplier may use his own or any other facilities suitable for the performance of the inspection requirements specified herein, unless disapproved by the Government. The Government reserves the right to perform any of the inspections set forth in the specification where such inspections are deemed necessary to assure supplies and services conform to prescribed requirements.

4.1.1 Responsibility for compliance

All items must meet all requirements of section 3 and 5. The inspection set forth in this specification shall become a part of the contractor's overall inspection system or quality program. The absence of any inspection requirements in the specification shall not relieve the contractor of the responsibility of assuring that all products or supplies submitted to the Government for acceptance comply with all requirements of the contract. Sampling in quality conformance does not authorize submission of known defective material, either indicated or actual, nor does it commit the Government to acceptance of defective material.

4.2 Classification of inspections

The inspection requirements specified herein shall conform to the end item inspection in 4.4.

4.3 Inspection conditions

Unless otherwise specified, sampling for inspection and acceptance shall be in accordance with provisions of MIL-STD-105.

4.4 End item inspection

Examination of the end item shall be made in accordance with the classification of defects (Table V) and 4.4.3. The lot size for the purpose of determining the sample size shall be expressed in units of boxes for examinations under 4.4.1 and in units of bundles, pallet loads, or shipping containers of knocked-down boxes, as applicable, for examination in 4.4.2.

4.4.1 Quality conformance inspection sampling

The sample unit shall be carefully examined to determine conformance with materials, construction, appearance and workmanship requirements of section 3 (see Table V). The sample unit for this examination shall be one completely fabricated box, including box top. The inspection level, major and minor defects shall conform to 4.4.3.

TABLE V. Classification of Defects

| Examine | Defect | Category | |
|-----------------------|---|----------|-------|
| | | Major | Minor |
| Material | Materials not as specified... | 101 | |
| | Fasteners not type and size specified; not cement coated or chemically etched | 102 | |
| | Plywood less than specified thickness..... | 103 | |
| | Cleats less than specified width and thickness..... | 104 | |
| Base | Base components not as specified (see 3.2)..... | 105 | |
| | Skids not in accordance with requirements (see 3.2)..... | 106 | |
| | Rubbing Strips improperly spaced, beveled, sized or missing..... | 107 | |
| | Carriage bolts not as specified (see 3.3.2.3)..... | 108 | |
| | Lag bolts improperly spaced or missing..... | 109 | |
| Splicing of panel | Panel up to and including 48 inch width by 72 inch length made up of more than one piece of plywood..... Note: Panels which exceed either of the above dimensions may be of one or two pieces and lap or butt joined. Lap joint of two-piece panel less than 3 inches and either piece greater than 3/16 inch in thickness | | 201 |
| | Lap joint not secured by two rows of metal stitches passing through both pieces | 110 | |
| | Stitches not parallel..... | | 202 |
| | Stitches spaced less than 2 inches apart..... | | 203 |
| | Spacing of stitches more than 4 inches apart | 111 | |
| | Butt joint of 2-piece panel not secured with wood cleat centered over joint | 112 | |
| | Cleat not fastened to each piece of panel as required for fabrication of panels (see 3.2.5.1) | 113 | |
| | Joint cleat for domestic type box or for overseas type box, as applicable, not as specified | 114 | |
| Construction of panel | Cleat not properly positioned | 125 | |
| | Cleat not of sufficient length | | 204 |
| | Intermediate or additional cleat missing where required (see 3.2.5.1) | 116 | |
| | Assembly not in true alignment.... | | 205 |
| | Staple or other fastener not fully and securely driven through adjoining members as specified | 117 | |
| | Staple leg or other fastener point not completely clinched 1/8 inch or more | 118 | |
| | Protrusion of fastener point | 119 | |

| | | | |
|-----|--|-----|-----|
| | side member | | |
| | Fastener does not pass through plywood and cleat as applicable to permit clinching | 120 | |
| | Bearing surface of staple crown or nail head overdriven in excess of 1/32 Inch in plywood less than 1/4 inch thick | 121 | |
| | Joint and joist supports not as specified | 122 | |
| | Box not type and style specified | 123 | |
| Box | Spacing between metal fasteners in excess of maximum length specified | | 206 |
| | Fasteners positioned lengthwise of cleats not staggered where possible to form two parallel rows | | 207 |
| | Less than 3/8 inch between nearest edge of fastener and edge of cleat | 124 | |

4.4.2 Examination of packaging

Examination shall be made to determine that packing and marking comply with the requirements of section 5, Table VI and special requirement of contract, when applicable. The sample unit shall be one shipping crate or bundle of unassembled boxes.

TABLE VI. Examination of Packaging

| Examine | Defect | Category | |
|------------------------|---|----------|-------|
| | | Major | Minor |
| Packing | All unassembled units not complete (Base, side panels, end panels and assembling hardware) within bundle, pallet load or shipping container | 101 | |
| | Units not uniform, neat, or securely bundled, palletized or crated | 102 | |
| | Overall height of stacked units not within 43 inch limitation.... | 103 | |
| Identification Marking | Bundle, pallet load, or shipping container not marked to identify contents | 104 | |
| Marking for Shipment | Omitted, incomplete, incorrect, illegible, of improper size, location, sequence, or method of application | 105 | |

4.4.3 Inspection levels and AQLs for examinations

The inspection levels for the purpose of determining the sample size and the AQLs expressed in defects per hundred units shall be as follows:

| Examination Paragraph | Inspection level | AQL | |
|-----------------------|------------------|-------|-------|
| | | Major | Minor |
| 4.4.1 | S-4 | 2.5 | 6.5 |
| 4.4.2 | S-2 | 4.0 | 4.0 |

5. PACKAGING

5.1 Packing

Unless otherwise specified (see 6.2), packing shall be level C. (See 4.4.2).

5.1.1 Level C

Level C pack shall be used immediately at the first receiving activity. Boxes shall be shipped assembled or unassembled (see 6.2). The assembled or unassembled unit will consist of the complete fabricated top, sides, and end panels, secured to the base. Unit(s) shall be bundled, palletized, or crated in a manner which will ensure carrier acceptance and safe delivery to the destination specified in the acquisition document. The hardware shall be placed in a container (box, bag, envelope) of suitable strength and size in a protected location and secured to prevent separation from the packed unit. Provisions for strapping shall be in accordance with PPP-B-601. Stacking of the unassembled box units shall not exceed 4 3 inches in height. (See 4.4.2).

5.2 Preservation

The hardware, for unassembled boxes, required for final assembly of the box shall be treated with corrosion preventive compound, grade 1 of MIL-C-16173.

5.3 Marking for shipment

In addition to any special marking required in contract or purchase order (see 6.2), shipments shall be marked in accordance with the requirements of MIL-STD-129. (See 4.4.2).

6. NOTES

6.1 Intended use

Boxes covered by this specification are intended to be used for items which can be attached to a load-bearing base. It is intended that the entire load be carried on the base, the superstructure providing only for superimposed loads and protection against the elements. When the physical protection afforded by the superstructure is not required for storage and shipment, the superstructure may be removed. It is not intended for the box to be lifted and moved other than by the base.

6.2 Ordering data

Acquisition documents should specify the following:

- (a) Title, number, and date of this specification.
- (b) Type, style, and class of box required (see 3.5).
- (c) Type of flooring for base (see 1.2).
- (d) Whether fire-retardant materials are required (see 3.1).
- (e) Plywood sanded (see 3.1.2).

- (f) Plywood treated (see 3.1.2).
- (g) If beveling of skids is required (see 3.2).
- (h) Weight of contents (see Table I).
- (i) If rubbing strips are required (see 3.2.4).
- (j) Type of superstructure (see 3.2.5).
- (k) Joist requirement (see 3.2.5.2).
- (l) Inside dimensions specified in inches to the nearest 1/2 inch in order of: length by width by depth (see 3.3.1).
- (m) Assembled or knocked-down (see 3.4.2 and 5.1.1).
- (n) When corner straps are required (see 3.4.2.4).
- (o) Whether ventilation holes or slots are required (see 3.7).
- (p) Packing instructions if different (see 5.1).
- (q) Special marking if required (see 5.2).
- (r) Load condition (see Figures 3 and 4).

6.3 Metric conversions

Metric conversions are compiled in Table VII, which conforms to ASTM E380.

Table VII. Metric Conversions

| English | Metric | Reference |
|---------------|---------|---|
| 2500 lbs | 1134 kg | 1.1, Table I |
| 16 ft | 4.9 m | 1.1, Table I |
| 36 in or 3 ft | 91 cm | 3.2, Table II, 3.2.3, 3.2.5.2, 3.3.2.1 |
| 24 in | 61 cm | 3.2, Tables II & III, 3.2.5.2 |
| 60 in | 152 cm | 3.2, Tables II & III, 3.2.4 3.4.2.1, 3.4.2.3, Fig 6 |
| 72 in | 183 cm | 3.2 Table V |
| 100 lbs | 45 kg | Table I |
| 101 lbs | 46 kg | Table I |
| 200 lbs | 91 kg | Table I |
| 201 lbs | 91 kg | Table I |
| 400 lbs | 181 kg | Table I |
| 401 lbs | 182 kg | Table I |
| 600 lbs | 272 kg | Table I |
| 601 lbs | 273 kg | Table I |
| 800 lbs | 363 kg | Table I |
| 801 lbs | 363 kg | Table I |
| 1000 lbs | 454 kg | Table I, 3.2.5, 3.3.3.1.1 |
| 1001 lbs | 454 kg | Table I |
| 1200 lbs | 544 kg | Table I |
| 1201 lbs | 545 kg | Table I |
| 1400 lbs | 635 kg | Table I |
| 1401 lbs | 635 kg | Table I |
| 1600 lbs | 726 kg | Table I |
| 1601 lbs | 726 kg | Table I |
| 1800 lbs | 816 kg | Table I |
| 1801 lbs | 817 kg | Table I |
| 2000 lbs | 907 kg | Table I |
| 2001 lbs | 908 kg | Table I |

Military Specification – Boxes, Wood-Cleated, Skidded, Load-Bearing Base

| | | |
|---------------|-----------|--|
| 2200 lbs | 998 kg | Table I |
| 2201 lbs | 998 kg | Table I |
| 2400 lbs | 1089 kg | Table I |
| 2401 lbs | 1089 kg | Table I |
| 2 in | 5 cm | Tables I, III & V, 3.2.3, 3.3.2.3, 3.3.3.1.1, 3.4.2.1, 3.4.2.2, 3.5.2, Figs 6, 9 |
| 4 in | 10 cm | Table I, III & V, 3.2.1, 3.2.3, 3.2.4, 3.3.2.3, Figs 2, 5, 6, 9 |
| 6 in | 15 cm | Table I, Fig 5 |
| 8 in | 20 cm | Table I, Fig 5 |
| 48 in or 4 ft | 122 cm | Tables I, II & V |
| 5 ft | 1.5 m | Table I |
| 7 ft | 2.1 m | Table I |
| 8 ft | 2.4 m | Table I |
| 9 ft | 2.7 m | Table I |
| 10 ft | 3.0 m | Table I, 3.5 |
| 11 ft | 3.4 m | Table I |
| 12 ft | 3.7 m | Table I |
| 13 ft | 4.0 m | Table I |
| 14 ft | 4.3 m | Table I |
| 15 ft | 4.6 m | Table I |
| 18 ft | 5.5 m | Table I |
| 1 in | 2.5 cm | Tables II & III, 3.2.1, 3.3.3.1.1, 3.4.2.4, 3.7, Fig 9 |
| 3 in | 8 cm | Tables II & V, 3.2.4, 3.3.3.1.2, 3.4.2.1, 3.4.2.2, 3.4.2.3, Figs 6, 7 |
| 12 in | 30 cm | Table II, 3.2.4, 3.4.2.1, 3.4.2.2, 3.4.2.4, Figs 6, 9 |
| 18 in | 46 cm | Table II, 3.4.2.1, Fig 6 |
| 30 in | 76 cm | Table II |
| 42 in | 107 cm | Table II |
| 54 in | 137 cm | Table II |
| 38 lbs/in | 6.8 kg/cm | Table II |
| 26 lbs/in | 6.4 kg/cm | Table II |
| 19 lbs/in | 3.4 kg/cm | Table II |
| 15 lbs/in | 2.7 kg/cm | Table II |
| 13 lbs/in | 2.3 kg/cm | Table II |
| 11 lbs/in | 2.0 kg/cm | Table II |
| 10 lbs/in | 1.8 kg/cm | Table II |
| 9 lbs/in | 1.6 kg/cm | Table II |
| 7 lbs/in | 1.3 kg/cm | Table II |
| 46 lbs/in | 8.2 kg/cm | Table II |
| 31 lbs/in | 5.5 kg/cm | Table II |
| 23 lbs/in | 4.1 kg/cm | Table II |
| 18 lbs/in | 3.2 kg/cm | Table II |
| 16 lbs/in | 2.9 kg/cm | Table II |
| 12 lbs/in | 2.1 kg/cm | Table II |
| 8 lbs/in | 1.4 kg/cm | Table II |

Military Specification – Boxes, Wood-Cleated, Skidded, Load-Bearing Base

| | | |
|------------|------------|--|
| 176 lbs/in | 31.5 kg/cm | Table II |
| 118 lbs/in | 21.1 kg/cm | Table II |
| 88 lbs/in | 15.7 kg/cm | Table II |
| 70 lbs/in | 12.6 kg/cm | Table II |
| 58 lbs/in | 10.4 kg/cm | Table II |
| 52 lbs/in | 9.3 kg/cm | Table II |
| 44 lbs/in | 7.9 kg/cm | Table II |
| 39 lbs/in | 7.0 kg/cm | Table II |
| 35 lbs/in | 6.3 kg/cm | Table II |
| 211 lbs/in | 37.7 kg/cm | Table II |
| 142 lbs/m | 25.4 kg/cm | Table II |
| 106 lbs/in | 18.9 kg/cm | Table II |
| 84 lbs/in | 15.0 kg/cm | Table II |
| 62 lbs/in | 11.1 kg/cm | Table II |
| 53 lbs/in | 9.5 kg/cm | Table II |
| 47 lbs/in | 8.4 kg/cm | Table II |
| 42 lbs/in | 7.5 kg/cm | Table II |
| 459 lbs/in | 82.0 kg/cm | Table II |
| 306 lbs/in | 54.6 kg/cm | Table II |
| 230 lbs/in | 41.1 kg/cm | Table II |
| 183 lbs/in | 32.7 kg/cm | Table II |
| 154 lbs/in | 27.5 kg/cm | Table II |
| 131 lbs/in | 23.4 kg/cm | Table II |
| 115 lbs/in | 20.5 kg/cm | Table II |
| 102 lbs/in | 18.2 kg/cm | Table II |
| 92 lbs/in | 16.4 kg/cm | Table II |
| 551 lbs/in | 98.4 kg/cm | Table II |
| 367 lbs/in | 65.5 kg/cm | Table II |
| 276 lbs/in | 49.3 kg/cm | Table II |
| 220 lbs/in | 39.3 kg/cm | Table II |
| 185 lbs/in | 33.0 kg/cm | Table II |
| 157 lbs/m | 28.0 kg/cm | Table II |
| 138 lbs/in | 24.6 kg/cm | Table II |
| 122 lbs/in | 21.8 kg/cm | Table II |
| 110 lbs/m | 19.6 kg/cm | Table II |
| 3/8 in | 0.95 cm | 3.2.2, 3.3.2.3, 3.3.2.4, 3.4.2.3, Table V, Figs 5, 9 |
| 1/8 in | 0.32 cm | 3.2.4, 3.3.2.2, 3.3.3.1.2, 3.3.3.1.3, 3.4.2.4, Table V, Figs 2, 5 |
| 2-1/2 in | 6.4 cm | 3.2.4, 3.4.2.3 |
| 28 in | 71 cm | 3.2.4 |
| 16 in | 41 cm | 3.2.4 |
| 25 in | 64 cm | Table III |
| 37 in | 94 cm | Table III |
| 1/4 in | 0.64 cm | 3.3.2.1, 3.3.2.2, 3.3.3.1.2, 3.3.3.1.3, 3.4.2.3, Table V, Figs 2, 5, 9 |
| 1/2 in | 1.3 cm | 3.3.2.1, 6.2 |
| 3-1/2 in | 8.9 cm | 3.3.3.1.3 |
| 15/16 in | 2.38 cm | 3.4.2.3 |
| 3/4 in | 1.91 cm | 3.4.2.4, 3.5, 3.5.2, Table |

| | | |
|-----------|------------|-----------------|
| | | IV, Figs 5, 9 |
| 0.020 in | 0.05 cm | 3.4.2.4 |
| 7/8 in | 2.22 cm | 3.4.2.4 |
| 1-1/8 in | 2.87 cm | 3.4.2.4 |
| 1 sq in | 6.45 sq cm | 3.5 |
| 100 cu ft | 2.83 cu m | Table IV |
| 150 cu ft | 4.25 cu m | Table IV |
| 200 cu ft | 5.66 cu m | Table IV |
| 400 cu ft | 11.3 cu m | Table IV |
| 600 cu ft | 17.0 cu m | Table IV |
| 7 sq in | 45 sq cm | Table IV |
| 10 sq in | 65 sq cm | Table IV |
| 14 sq in | 90 sq cm | Table IV |
| 27 sq in | 174 sq cm | Table IV |
| 40 sq in | 258 sq cm | Table IV |
| 3/16 in | 0.48 cm | Table V |
| 1/32 in | 0.03 cm | Table V |
| 43 in | 109 cm | Table VI, 5.1.1 |

6.3.1

Nominal sizes shall be defined in accordance with MIL-STD-731, table I.

6.4 Subject term (key word) listing

- Boxes
- Boxes, wood-cleated, skidded, load-bearing base
- Container
- Container, load-bearing base
- Packaging
- Packaging, boxes
- Packaging, container
- Packaging, load-bearing base
- Packaging, wood-cleated
- Packaging, skidded

6.5 Changes from previous issue

Asterisks (or vertical lines) are not used in this revision to identify changes with respect to the previous issue due to the extensiveness of the changes.

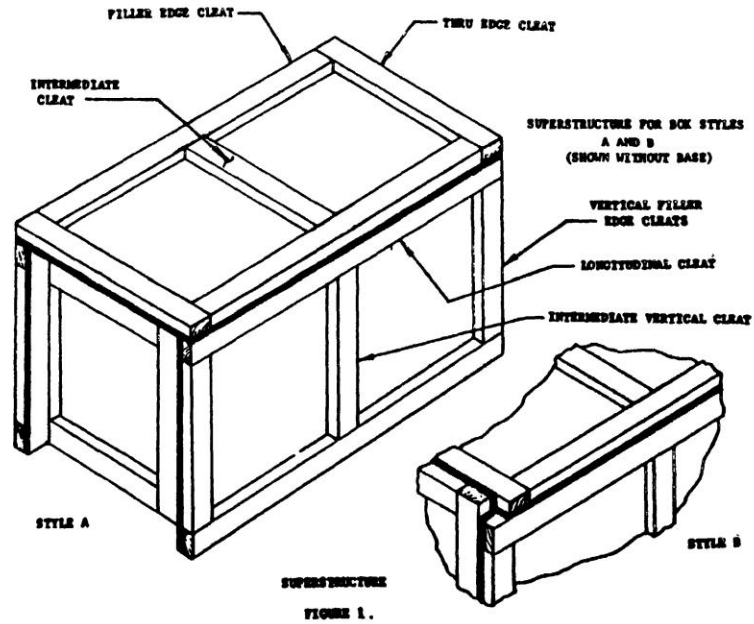

Figure 1. Style A container: The line at the bottom of the lower horizontal filler cleat should be extended across the bottom of the left vertical edge cleat.

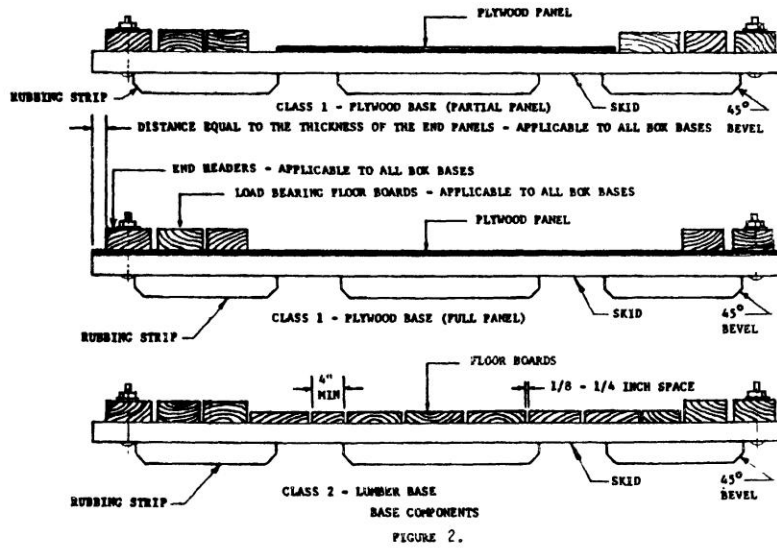
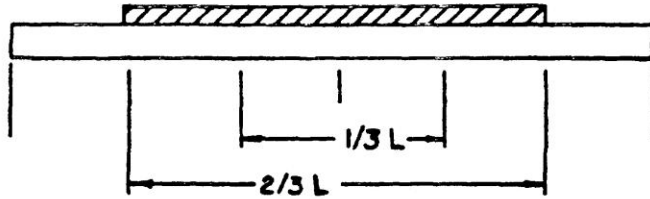
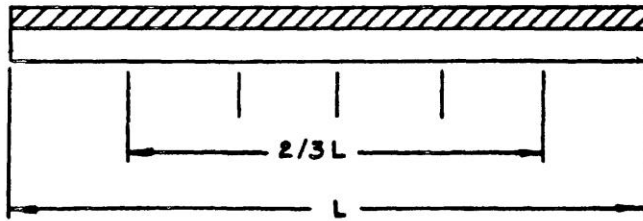

FIGURE 2.



LOAD CONDITION D - LOAD EVENLY DISTRIBUTED OVER MORE THAN CENTRAL ONE-THIRD OF SKID LENGTH BUT NOT OVER MORE THAN CENTRAL TWO-THIRDS OF SKID LENGTH



LOAD CONDITION E - LOAD EVENLY DISTRIBUTED OVER MORE THAN CENTRAL TWO-THIRDS OF SKID LENGTH

FIGURE 3. LOAD CONDITIONS D AND E

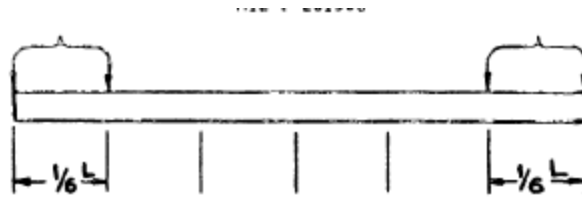

LOAD CONDITION A. LOAD BEARING POINTS ON OUTER ONE-SIXTH OF SKID LENGTH

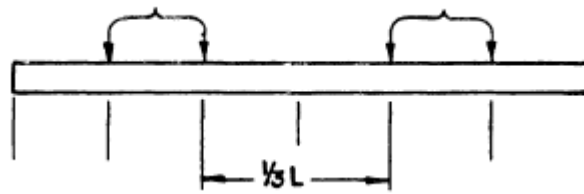

LOAD CONDITION B. LOAD BEARING POINTS OUTSIDE OF CENTRAL ONE-THIRD OF SKID LENGTH BUT NOT IN OUTER ONE-SIXTH OF SKID LENGTH

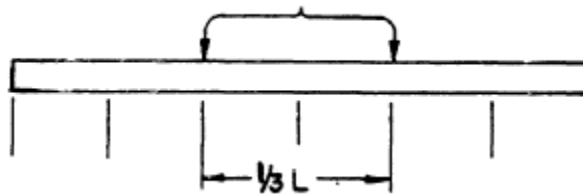

LOAD CONDITION C. LOAD BEARING POINTS WITHIN CENTRAL ONE-THIRD OF SKID LENGTH OR LOAD EVENLY DISTRIBUTED WITHIN CENTRAL ONE-THIRD OF SKID LENGTH

FIGURE 4. LOAD CONDITIONS A, B, AND C

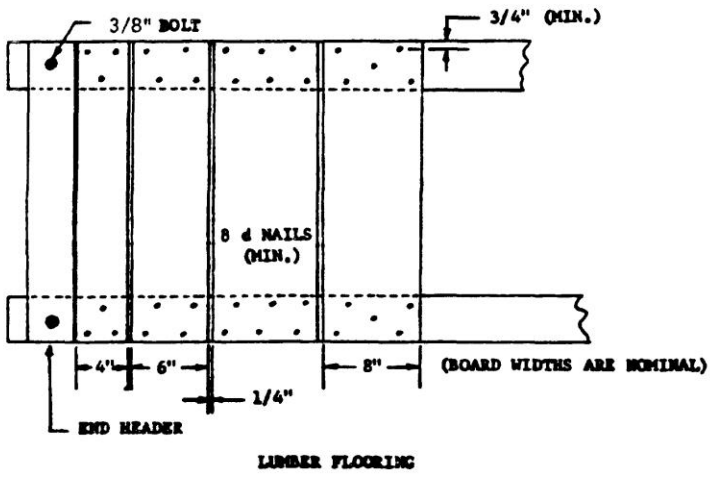
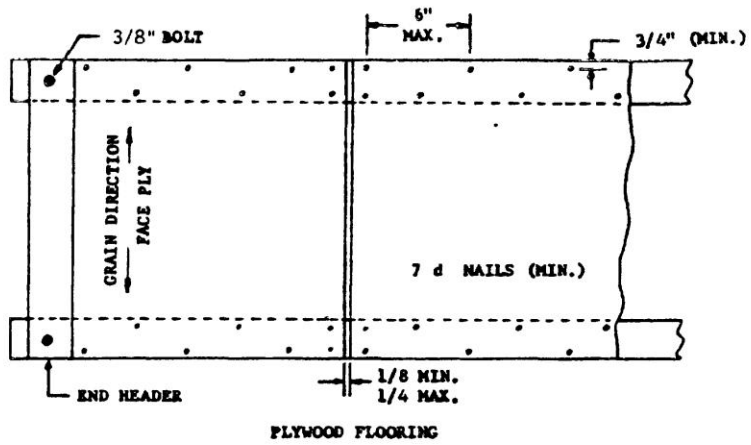

MAILING PATTERN FOR BASE

FIGURE 5.

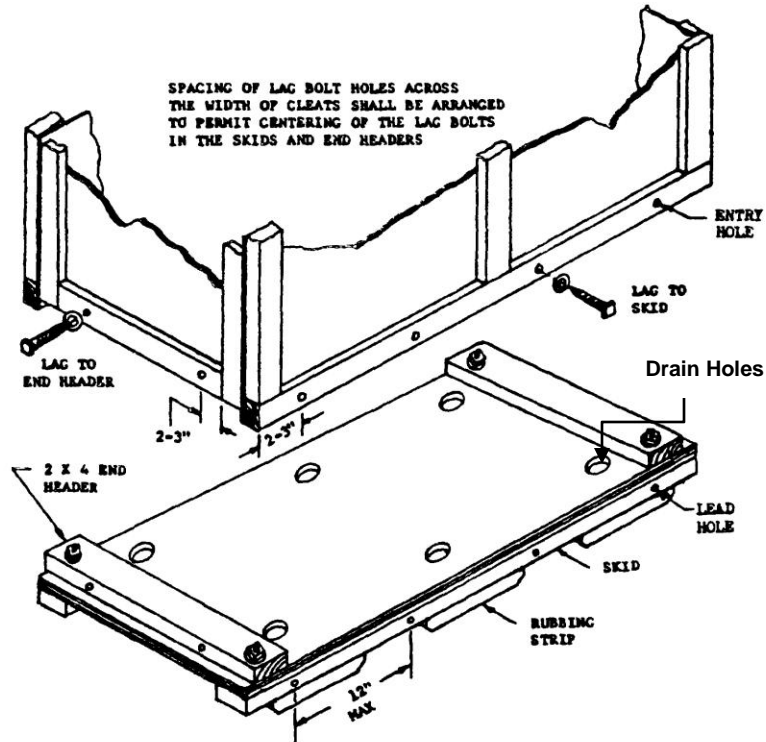

18" max for crates 60 inches or less

FIGURE 6. ASSEMBLY OF PANELS TO BASE

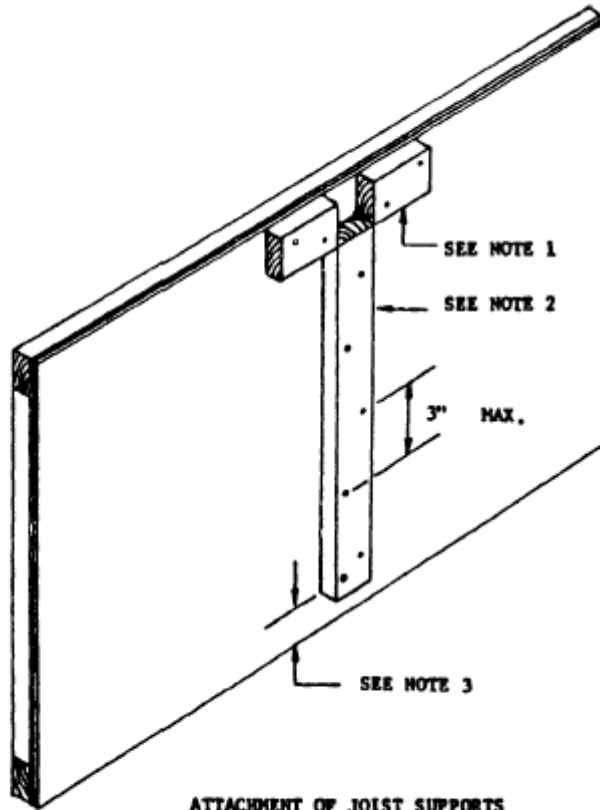

ATTACHMENT OF JOIST SUPPORTS
FIGURE 7.

1. Lateral joists shall be placed such that a GAP OF 1 5/8" to 1 3/4" is created.
2. VERTICAL SUPPORT **FOR** JOIST
3. VERTICAL SUPPORT TO REST ON FLOOR OF **BASE** OR ON LOADBEAMNG MEMBERS AS APPLICABLE

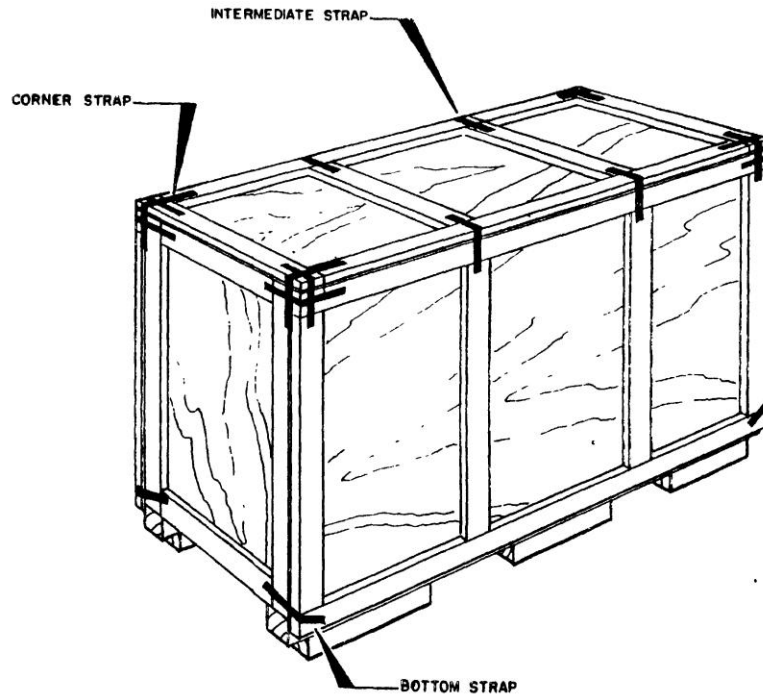

PLACEMENT OF STRAPS

FIGURE 8.

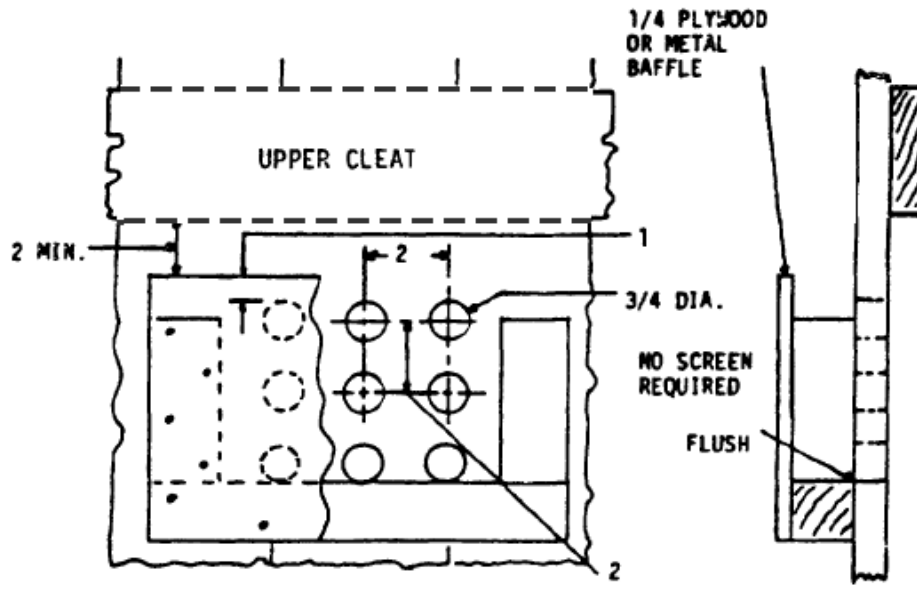

Ventilation Holes.

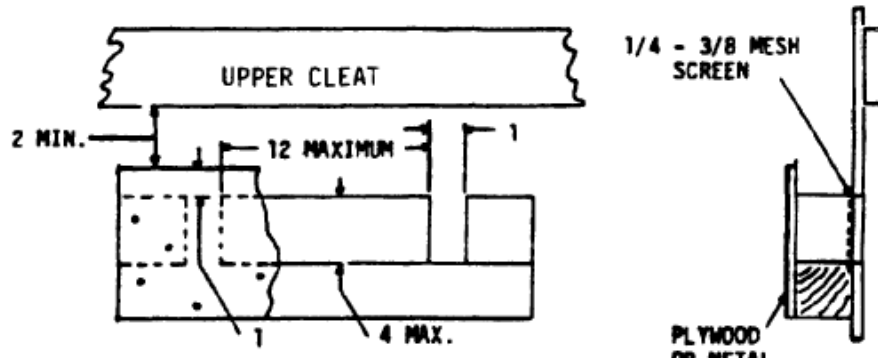

Ventilation Slots.

Note: All dimensions are in inches.

Figure 9. Box Ventilation (Inside View)

APPENDIX

HAZARDOUS MATERIALS REQUIREMENTS

10. SCOPE

10.1 Scope

This Appendix is a mandatory part of this specification. The information contained herein is intended for compliance if hazardous materials are to be shipped in the subject containers. Hazardous Material Boxes with a maximum net mass of 882 pounds and intended for shipment or storage of regulated materials as defined in 49 Code of Federal Regulations (CFR), Part 173 or international transportation regulations (ICAO "Technical Instructions for the Safe Transport of Dangerous Goods by Air" or IMO "International Maritime Dangerous Goods" herein referred to as "hazardous material boxes". Substitutions or deviations must be approved by the ordering activity and comply with 49 CFR 178.601 as different packaging. All Department of Defense shipments must meet the requirements for shipping by land, sea and air.

20. APPLICABLE DOCUMENTS

20.1 Government documents

20.1.1 Other government documents and publications

The following other Government documents and publications form a part of this Appendix to the extent specified herein. Unless otherwise specified, the issues are those cited in the solicitation.

DEPARTMENT OF TRANSPORTATION

49 Code of Federal regulations, parts 100-199

[\(Applications for copies should be addressed to the Superintendent of Documents, U.S. Government Printing Office, Washington D.C. 20402.\)](#)

20.2 Non Government Publication

The following documents form a part of this Appendix to the extent specified herein. Unless otherwise specified, the issues of the documents which are Duo adopted are those listed in the issue of the DODISS specified in the solicitation. Unless otherwise specified, the issues of documents not listed in the DODISS are the issues of the documents cited in the solicitation.

ASTM D 4919

Standard Specification for Testing of Hazardous Materials Packaging

[\(Application for copies of the ASTM standards by serial designation and title should be made to ASTM, 1916 Race Street, Philadelphia PA 19103\)](#)

INTERNATIONAL CIVIL AVIATION ORGANIZATIONS (ICAO)

Technical Instructions for the Safe Transport of Dangerous Goods by Air

(Applications for copies should be addressed to Labelmaster Division, American Labelmark Company, 5724 North Pulaski Rd., Chicago IL 60646.)

INTERNATIONAL MARITIME ORGANIZATION

International Maritime Dangerous Goods (IMDG) Code

(Applications for copies should be addressed to Labelmaster Division, American Labelmark Company, 5724 North Pulaski Rd. Chicago IL 60646.)

20.3 Order of precedence

Nothing in this Appendix supersedes applicable laws and regulations unless a specific exemption has been obtained in writing from their competent authority.

30. REQUIREMENTS

30.1 Hazardous materials boxes

Boxes, also known as packaging, for hazardous material storage and transportation shall conform to 49 CFR (Part 173 Subpart B and Part 178 Subpart L), IMDG, or ICAO Technical Instructions (Part 3, Chapter 1 and Part 7). The Department of Defense considers the vibration test outlined in 30.1.2.3 as mandatory.

30.2 Test requirements

30.2.1 Rough handling (drop) test

Samples shall not exhibit any damage to the outer packaging which might adversely affect safety during transport. In addition, the inner packages shall not allow any leakage of filling substances into the outer packaging (see 40.2.1).

30.2.1 Stacking test

Test specimens shall not leak. For composite or combination packages, the filling substance shall not leak from the inner receptacle or packaging. Test samples shall not show any deterioration which might adversely affect transportation safety or any distortion which might reduce their strength, cause instability in stacking, or cause damage to inner packaging (see 40.2.2).

30.2.2 Vibration test

At the conclusion of the vibration test, there shall be no rupture or leakage from any of the packages. Test samples shall not show any distortion which could reduce packaging strength or any deterioration which might adversely affect transportation safety (see 40.2.3).

40. PERFORMANCE REQUIREMENTS

40.1 Specimen preparation

Properly assemble test load, including all internal configurations, place in box, and close as for transport. Complete all applicable preparation required by 49 CFR Part 178 Subpart M prior to initiation of testing. If an inner receptacle contains a liquid, the absorbent requirement shall conform to 49 CFR 173.27(e). Perform tests as required by 49 CFR 178 Subpart M using ASTM D 4919 guidance.

40.2 Performance tests

Hazardous materials boxes, as defined in paragraph 10.1 of this Appendix and domestic and international transportation regulations, shall pass the following tests.

40.2.1 Rough Handling (drop) test

(See 30.2.1)

40.2.1.1 Test load

The test load shall consist of a properly assembled load configuration as for shipment. This actual test load shall consist of one of the following:

40.2.1.1.1 The actual item

40.2.1.1.2 An accurate load simulation

(This includes, but is not limited to, accurate physical (i.e. fragility and **illegible**) and additional characteristics)

40.2.1.1.3

A simulated load per 49 CFR **illegible** the approved variations.

40.2.2 Stacking test

Perform test per 49 CFR 178 Subpart M.

40.2.3 Vibration test

Perform test per 49 CFR 178 Subpart M.

50. TEST REPORTS

50.1 Hazardous material, boxes test reports

The manufacturer or mark certifying activity, as defined in 49 CFR 178.2, shall supply two copies of the test report as required by the purchase (see 70.1 (c)). The mark certifying activity's test report shall document packaging limitations as identified by 49 CFR 178.2; results of the box testing required by 49 CFR 173.24, 49 CFR 178, and ASTM D 4919; and shall include the test configuration assembly. The format of the test report shall comply with Data item Description DI-PACK-81059.

60. MARKINGS

60.1 Hazardous materials boxes

The markings for hazardous materials boxes shall conform to 49 CFR Part 178 Subpart L and [MIL-STD-129](#), Appendix E.

70. NOTES

70.1 Acquisition requirements

Acquisition documents must specify the following:

- (a) Hazardous materials box.
- (b) Physical characteristics of load including dimensions, weight, and density of contents.
- (c) Distribution of test reports.

Military custodians:

Army – GL
Navy – SA
Air Force – 69

Preparing Activity:

Air Force: 69
Project No: 8115-0547

Review activities:

Army – AT, AR
NAVY – AS, SH, YD
Air Force – 70, 71

User Activities:

Army – AV
Navy – CG, MC

Other interest:

User – Coast Guard – CGS

Instructions and form for submitting changes has been removed.

© Copyright WoodenCRATES org, LLC, All Rights Reserved. May be distributed freely but not modified.