

# FED-STD-101 – Test Procedure for Packaging Materials

## Subject/Scope:

This standard covers the general physical and chemical testing procedures for determining the ability of preservation and packing to protect items during shipment and storage and determining the conformance of materials and containers with the requirements of specifications used by acquisition activities of the United States Government. This standard was prepared in order to eliminate unnecessary or undesirable variations in the general testing procedures, and to provide comparable measurements of the characteristics of different materials.

## Keywords:

Test, method, specimen, container, procedure, fed, material, report, weight, damage, packaging, packing, humidity, strength, temperature, drop, handling, requirement, shipping, shipment, blocking, vapor, heat, desiccant, vibration, corrosion, storage, cushioning, vacuum, federal, wood, flexible, shock, compression, motion, weight, protection, panel, moisture, DOD, plastic, bracing, preservative, corrugated, measure, desiccator, dunnage, fastener, vessel, transportation, plywood, case, forklift

## Published:

3/13/1980

Text in blue boxes such as this one is instructional and is intended to assist you in understanding the document.

Text in red boxes such as this explains changes made to the document by The Wooden Crates Organization.

**Red text has been added to the document or modifies the document since its final version was officially published.**

### Soft Conversion of Imperial to Metric

Conversions, when made, consider materials that are available in metric or imperial sizes rather than converting sizes exactly. For example: Panelboard (plywood) in the US is typically 4 feet X 8 feet (1220 x 2440 mm) while panelboard in metric countries is typically 1200 X 2400 mm. Since the standard was developed based on readily available materials these variations in material sizes could not have been practically considered.



The content of the document below has not been modified.

FED. TEST METHOD STD. NO. 101C

March 13, 1980

SUPERSEDING

Fed. Test Method Std. No. 101B

January 15, 1969

**FEDERAL TEST METHOD STANDARD**

**TEST PROCEDURES FOR PACKAGING MATERIALS**

This standard was approved by the Commissioner, Federal Supply Service, General Services Administration, for the use of all Federal agencies.

---

This document is available from the General Services Administration (GSA), acting as an agent for the Superintendent of Documents. A copy for bidding and contracting purposes is available from GSA Business Services Centers. Copies are for sale at the GSA, Specifications and Consumer Information Distribution Branch, Building 197 (Washington Navy Yard), Washington, DC 20407.

FSC PACK

## INFORMATION SHEET

ON

### FEDERAL TEST METHOD STANDARDS

This Federal Test Method Standard is issued in loose-leaf form to permit the insertion or removal of new or revised sections and test methods.

All users of Federal Test Method Standards should keep them up to date by inserting revised or new sections and test methods as issued and removing superseded and canceled pages.

New and revised material and cancellations will be issued under Change Notices which will be numbered consecutively and will bear the date of issuance. Change Notices should be retained and filed in front of the Alphabetical Index of the Standard until such time as they are superseded by a reissue of the entire Standard.

CHANGE NOTICES ARE NOT CUMULATIVE  
AND SHALL BE RETAINED UNTIL SUCH  
TIME AS THE STANDARD IS REVISED

FED. TEST METHOD STD. NO. 101C  
March 13, 1980  
CHANGE NOTICE 1  
October 8, 1982

FEDERAL TEST METHOD STANDARD

TEST PROCEDURES FOR PACKAGING MATERIALS

The following changes, which form a part of FEDERAL TEST METHOD STD. NO. 101C, dated March 13, 1980, were approved by the Commissioner, Federal Supply Service, General Services Administration, for the use of all Federal agencies:

1. Remove: Section 1, 2, 3, 4, 5 and 6 of March 13, 1980  
Add: Sections 1, 2, 3, 4, 5 and 6 of
2. Remove: Methods 1003.1, 1004, 2008, 2012, 2018, 2019, 2020, 2021, 2022, 2030, 2032, 2036.1, 2040, 2046.1, 2050, 2053, 2055, 2058, 2061, 2062, 2063, 2064, 2065, 3022, 3029, 3032, 3033, 4001, 4005, 4009, 4012, 4017, 4020, 4023, 4026, 4032, 4036, 4043, 4045, 4046, 4050, 5003, 5009.1, 5021, 5025, 6013, 6020, 6021 of March 13, 1980  
Add: Methods 1003.2, 2065.1, 4046.1, 5009.2.

RETAIN THIS CHANGE AND INSERT BEFORE THE TABLE OF CONTENTS

AREA PACK



CHANGE NOTICES ARE NOT CUMULATIVE  
AND SHALL BE RETAINED UNTIL SUCH  
TIME AS THE STANDARD IS REVISED

FED. TEST METHOD STD. NO. 101C  
March 13, 1980  
CHANGE NOTICE 2  
September 12, 1983

## FEDERAL TEST METHOD STANDARD

### TEST PROCEDURES FOR PACKAGING MATERIALS

The following changes, which form a part of FEDERAL TEST METHOD STD. No. 101C, dated March 13, 1980, were approved by the Assistant Administrator, Office of Federal Supply and Services, General Services Administration, for the use of all Federal agencies:

1. Remove from Section 2: Pages 7 through 18 of Change Notice 1  
Add to Section 2: Pages 7 through 18 of Change Notice 2
2. Remove from Section 3: Pages 19 through 24 of Change Notice 1  
Add to Section 3: Pages 19 through 24 of Change Notice 2
3. Remove from Section 4: Pages 25 through 32 of Change Notice 1  
Add to Section 4: Pages 25 through 31 of Change Notice 2  
and Page 32 of Change Notice 1
4. Remove from Section 5: Pages 33 through 46 of Change Notice 1  
Add to Section 5: Pages 33 through 40 of Change Notice 2,  
Page 41 of Change Notice 1, Pages 42  
through 46 of Change Notice 2
5. Remove Methods: 1002, 2001, 2003, 2004, 2006, 2008, 2009, 2010,  
2011, 2012, 2018, 2020, 2021, 2022, 2023, 2027,  
2028, 2029, 2030, 2034, 2039, 2045, 2046, 2047,  
2049, 3001, 3002, 3006, 3007, 3009, 3010, 3011,  
3013, 3018, 3019, 3021, 3023, 3025, 3029, 3031,  
4001, 4005, 4006, 4009, 4010, 4012, 4013, 4014,  
4015, 4016, 4017, 4019, 4020, 4023, 4024, 4030,  
4032, 4039, 4040, 4041, 4043, 4044, 4045, 5001,  
5002, 5003, 5006, 5025, 5026, 5027, 6003, 6004,  
6007, 6010, 6011, 6014, 6017, 6018, 6019, 6020,  
6021, 6023

Military Interest:

Civil Agency Coordinating Activity:  
GSA

Custodians:

Army - SM  
Navy - AS  
Air Force - 69

Preparing Activity:  
Navy - AS  
DOD Project PACK-0735

Review Activities:

Army - GL, MI, AR, ME, MR, EA  
Navy - OS, SH, SA, YD  
Air Force - 99

User Activities:

Army - AL, CR, AV  
Navy - EC, MC, CG

RETAIN THIS CHANGE AND INSERT BEFORE THE TABLE OF CONTENTS

AREA PACK



CHANGE NOTICES ARE NOT CUMULATIVE  
AND SHALL BE RETAINED UNTIL SUCH  
TIME AS THE STANDARD IS REVISED

FED. TEST METHOD STD. NO. 101C  
MARCH 13, 1980  
CHANGE NOTICE 3  
14 OCTOBER 1988

FEDERAL TEST METHOD STANDARD

TEST PROCEDURES FOR PACKAGING MATERIALS

The following changes, which form a part of FEDERAL TEST METHOD STD. No. 101C, dated March 13, 1980, were approved by the Assistant Administrator, Office of Federal Supply and Services, General Services Administration, for the use of all Federal agencies:

1. Remove from Section 2: Pages 9 through 18 of Change Notice 2.  
Add to Section 2: Pages 9 through 18 of Change Notice 3.
2. Remove from Section 3: Pages 19 through 24 and Pages 24A, 24B, 24C and 24D of Change Notice 2.  
Add to Section 3: Pages 19 through 24 and Pages 24A, 24B and 24C of Change Notice 3 and Page 24D of Change Notice 2.
3. Remove from Section 4: Pages 25 through 31 of Change Notice 2 and Page 32 of Change Notice 1.  
Add to Section 4: Pages 25 through 31 of Change Notice 3 and Page 32 of Change Notice 1.
4. Remove from Section 5: Pages 33 through 40 of Change Notice 2, Page 41 of Change Notice 1 and Pages 42 through 46 of Change Notice 2.  
Add to Section 5: Pages 33 through 45 of Change Notice 3 and Page 46 of Change Notice 2.
5. Remove Methods: 1001, 2002, 2005, 2013.1, 2017, 2025, 2033, 2035.1, 2037, 2043, 2044, 2051, 2052, 2054, 2056, 2057, 2059, 2060, 2071, 3004, 3014.1, 3015.1, 3016, 3017, 3020, 4002, 4007.1, 4008, 4011, 4018, 4035, 4047, 4048, 4049, 5009.2, 5013, 5015, 5024 and 6022.  
Add Methods: 2017.1, 3015.2 and 5009.3.

Military Interest:

Civil Agency Coordinating Activity:  
GSA

Custodians:

Army - SM  
Navy - AS  
Air Force - 69

Preparing Activity:  
Navy - AS  
DOD Project PACK-0845

Review Activities:

Army - GL, MI, AR, ME, MR, EA  
Navy - OS, SH, SA, YD  
Air Force - 99

User Activities:

Army - AL, CR, AV  
Navy - EC, MC, CG

RETAIN THIS CHANGE AND INSERT BEFORE THE TABLE OF CONTENTS

AMSC N/A

AREA PACK

DISTRIBUTION STATEMENT A: Approved for public release; distribution is unlimited.



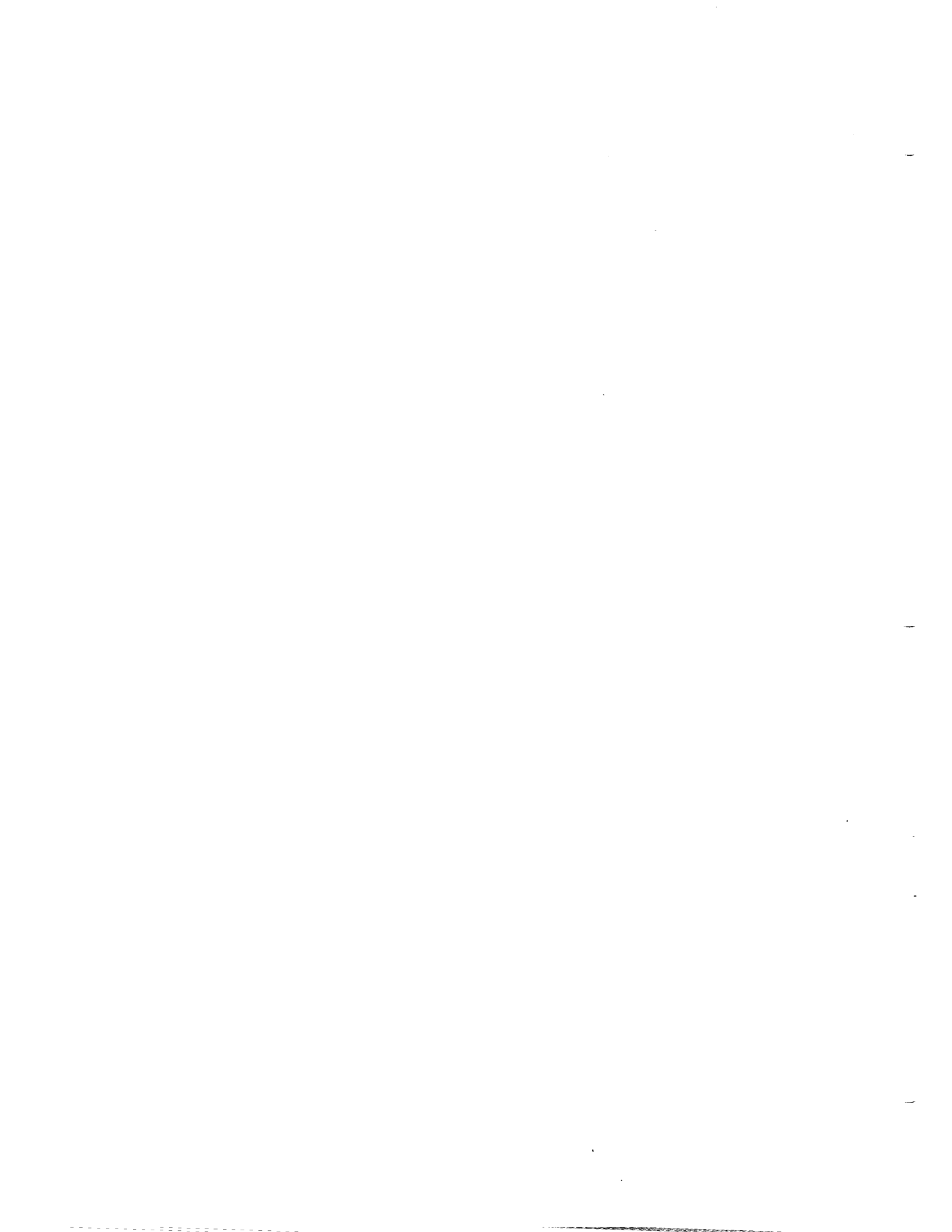

FEDERAL TEST METHOD STANDARD

TEST PROCEDURES FOR PACKAGING MATERIALS

This standard is approved by the Commissioner, Federal Supply Service, General Services Administration for the use of all Federal agencies.

SECTION 1

SCOPE AND CONTENTS

1. SCOPE

1.1 This standard covers the general physical and chemical testing procedures for determining the ability of preservation and packing to protect items during shipment and storage and for determining the conformance of materials and containers with the requirements of specifications used by acquisitioning activities of the United States Government. This standard was prepared in order to eliminate unnecessary or undesirable variations in the general testing procedures, and to provide comparable measurements of the characteristics of different materials.

1.1.1 In case of conflict between the provisions of these methods and the individual test procedures in specifications for particular materials, the latter shall take precedence.

1.2 New methods and revisions. The methods in this standard are prepared in looseleaf form for convenience in adding new and revised methods.

1.2.1 Each method is assigned a whole number and when it is necessary to correct or change an existing method, it is rewritten, a decimal number added to the whole number to indicate the revision, and the date changed to the current effective date. For example, if it should be necessary to rewrite method 2001 on Adhesion of Barrier Materials, dated January 15, 1969, the date would be changed accordingly and the numerical designation would become 2001.1. The decimal number indicates the first revision.

1.2.2 When referencing a test method in a detail specification or in another test method, the whole number only, without any decimal number that may appear in its current numerical designation, should be specified, with the intent that the latest revision in effect on date of invitation to bid will be used to conduct the test. For example, if the method for determining Tearing Resistance were currently designated as 2060.2, it should be specified as method 2060, but method 2060.2 would be used to conduct the test.

1.2.3 New, revised, and superseded methods may be obtained from the source listed for Federal Standardization Documents in Note 2, Section 6.

Supersedes unnumbered page of March 13, 1980

1.3 Index system.

1.3.1 Numerical index. The first part of the numerical index in section 2 lists the test methods with the former three digit code in the first column, the four digit code, introduced in revision "B" in the second column, revision "C" in the third column and the superseding ASTM standards in the fourth column. The second part of the numerical index lists the test method codes in the reverse order with revision "C" first and the former three digit code last. The numerical index allows for complete numerical cross referencing. Some former methods have been deleted or consolidated with other methods. New methods have been added as required.

1.3.2 Alphabetical index. In the alphabetical index of section 3, each method is listed by title, alphabetically. After each title the new four digit number is listed. All test methods that have been deleted or superseded by an ASTM standard are noted.

1.3.3 Group index. The introduction of the four digit test method code allowed for the assignment of codes according to the scopes of the test methods. The scopes were grouped into the measurements, properties or chemical analyses of packaging materials. The group index of section 4, as shown in (a) below, lists the test methods according to group number and scope. Superseding ASTM standards and titles of the test methods are noted.

(a) Groups:

- 1000 Dimensional measurements.
- 2000 Strength and elastic properties of materials.
- 3000 Resistance properties of materials.
- 4000 General physical properties.
- 5000 Properties of containers, packages, and packs.
- 6000 Chemical analyses.

1.3.4 Volume index. A new index has been added (section 5). This index organizes the test methods into volumes as shown in (a) below. Each volume deals with specific materials or test objective. All methods that have been superseded by an ASTM standard are noted.

(a) Volumes:

Volume I Tests for packaging materials.

- A. Corrugated paper and paperboard
- B. Cushioning materials

- C. Plastic, rigid, sheet film form
- D. General material tests
- E. Tapes

Volume II - Environmental Resistance Tests.

Volume III - Package and Product Performance.

1.4 Cross reference to ASTM or TAPPI. Many of the methods in this standard reference an ASTM standard, Technical Association of Pulp and Paper Industry (TAPPI) or other federal test methods rather than duplicate this method. In many cases the test methods in this standard are similar to, or contain applicable portions of the ASTM or TAPPI methods. (Referenced or superseding documents shall be those issues in effect on date of the latest revision to this standard.) Users of this standard must be cautioned that any variations between the ASTM or TAPPI methods and the methods contained herein will be resolved in favor of this standard where tests are being run on Government purchases, unless the method has been noted as being superseded by an ASTM standard.

2. CONTENTS

2.1 The contents of this standard are as follows:

Sections:	Page
1. Scope and contents . . . . .	3
2. 3-digit number replacements . . . . .	7
3. Alphabetical index of test methods . . . . .	19
4. Numerical index of test methods. . . . .	25
5. Volume index of test methods . . . . .	33
6. Notes . . . . .	47

Test methods:

In numerical order.

Supersedes unnumbered page of March 13, 1980

FED. TEST METHOD STD. NO. 101C  
March 13, 1980  
CHANGE NOTICE 1  
October 8, 1982

Supersedes unnumbered page of March 13, 1980

SECTION 2

Cross references of corresponding methods in FED. Test Method Std. No. 101A and 101B and 101C relative to the old 3 digit number of 101A and to new 4 digit number of 101B and 101C.

101A Method No.	101B Method No.	101C Method No.	Superseding ASTM Method No.
100	Deleted	Deleted	
101	Deleted	Deleted	
102	Deleted	Deleted	
103	Deleted	Deleted	
104	Deleted	Deleted	
105	Deleted	Deleted	
106	3029	Deleted	D 724
107	2048	Deleted	
108	Deleted	Deleted	
109	Deleted	Deleted	
110	2027	Deleted	
111	Deleted	Deleted	
112	2031	2031	
113	Deleted	Deleted	
114	Deleted	Deleted	
115	Deleted	Deleted	
116	Deleted	Deleted	
117	Deleted	Deleted	
118	Deleted	Deleted	
119	Deleted	Deleted	
120	Deleted	Deleted	
121	Deleted	Deleted	
122	Deleted	Deleted	
123	4029	Deleted	
124	Deleted	Deleted	
125	3021	Deleted	
126	6007	Deleted	
127	6023	Deleted	
128	6003	Deleted	
129	6003	Deleted	
130	Deleted	Deleted	
131	4015	Deleted	
132	Deleted	Deleted	
133	4040	Deleted	
134	4030	Deleted	
135	6004	Deleted	
136	Deleted	Deleted	
137	Deleted	Deleted	
138	Deleted	Deleted	
139	Deleted	Deleted	
140	Deleted	Deleted	

March 13, 1980

CHANGE NOTICE 2

September 12, 1983

SECTION 2 (Continued)

Cross references of corresponding methods in FED. Test Method Std. No. 101A and 101B and 101C relative to the old 3 digit number of 101A and to new 4 digit number of 101B and 101C.

101A Method No.	101B Method No.	101C Method No.	Superseding ASTM Method No.
141	Deleted	Deleted	
142	Deleted	Deleted	
143	Deleted	Deleted	
144	6010	Deleted	
145	Deleted	Deleted	
146	Deleted	Deleted	
147	Deleted	Deleted	
148	Deleted	Deleted	
149	Deleted	Deleted	
150	Deleted	Deleted	
151	Deleted	Deleted	
152	Deleted	Deleted	
153	Deleted	Deleted	
154	Deleted	Deleted	
155	2029	Deleted	
156	Deleted	Deleted	
157	6012	Deleted	
158	2049	Deleted	
159	Deleted	Deleted	
160	2001	Deleted	
161	Deleted	Deleted	
162	2004	Deleted	
163	3011	Deleted	
164	Deleted	Deleted	
165	2014	Deleted	
166	Deleted	Deleted	
167	3013	Deleted	
168	5004	Deleted	
169	Deleted	Deleted	
170	2022	Deleted	D 1238
171	Deleted	Deleted	
172	Deleted	Deleted	
173	4024	Deleted	
174	4019	Deleted	
175	Deleted	Deleted	
176	Deleted	Deleted	
177	4013	Deleted	
178	Deleted	Deleted	
179	Deleted	Deleted	
180	Deleted	Deleted	

SECTION 2 (Continued)

Cross references of corresponding methods in FED. Test Method Std. No. 101A and 101B and 101C relative to the old 3 digit number of 101A and to new 4 digit number of 101B and 101C.

101A Method No.	101B Method No.	101C Method No.	Superseding ASTM Method No.
181	Deleted	Deleted	
182	Deleted	Deleted	
183	2015	2015.1	
184	Deleted	Deleted	
185	4043	Superseded	C 177
186	Deleted	Deleted	
187	3018	Deleted	
188	Deleted	Deleted	
189	Deleted	Deleted	
190	Deleted	Deleted	
191	Deleted	Deleted	
192	3009	Deleted	
193	Deleted	Deleted	
194	Deleted	Deleted	
195	Deleted	Deleted	
196	Deleted	Deleted	
197	Deleted	Deleted	
198	Deleted	Deleted	
199	Deleted	Deleted	
200	Deleted	Deleted	
201	Deleted	Deleted	
202	Deleted	Deleted	
203	6002	Deleted	
204	5022	5022.1	
205	5024	Deleted	
206	6005	Deleted	
207	6006	Deleted	
208	5027	Deleted	
209	5016	5016.1	
210	5017	5017	
211	5023	5023	
212	5012	5012	
213	5008	5008.1	
214	5005	5005.1	
215	5018	5018	
216	5007	5007.1	
217	5001	Deleted	
218	2047	Deleted	
219	4002	Deleted	
220	4018	Superseded	E462, E619

\* Comparable test methods; not DOD adopted  
Supersedes page 9 of September 12, 1983



SECTION 2 (Continued)

Cross references of corresponding methods in FED. Test Method Std. No. 101A and 101B and 101C relative to the old 3 digit number of 101A and to new 4 digit number of 101B and 101C.

101A Method No.	101B Method No.	101C Method No.	Superseding ASTM Method No.
221	6017	Deleted	
222	4010	Deleted	
223	3003	3003	
224	2043	Deleted	
225	2041	Deleted	
226	2045	Deleted	
227	2044	Superseded	*D3953
228	2042	Deleted	
229	3008	Deleted	
230	2005	Deleted	
231	2006	Deleted	
232	6018	Deleted	
233	3020	Deleted	
234	2034	Deleted	
235	4014	Deleted	
236	5011	5011.1	
237	6011	Deleted	
238	1001	Deleted	
239	5015	Deleted	
240	5014	5014	
241	5009	5009.2	
242	2023	Deleted	
243	5013	Deleted	
244	2003	Deleted	
245	2040	Superseded	D 638
246	2038	2038	
247	2039	Deleted	
248	2037	Deleted**	
249	6013	Superseded	D 1030
250	2007	2007.1	
251	6019	Deleted	
252	5021	Superseded	D 1008, D 895
253	6001	Deleted	
254	3001	Deleted	
255	2002	Deleted	
256	4006	Deleted	
257	4011	Deleted	
258	Deleted	Deleted	
259	2024	2024	
260	3015	3015.2	
261	3016	Deleted	

\* Comparable test methods; not DoD adopted

\*\* Use FED-STD-191, Methods 5100 or 5102  
Supersedes page 10 of September 12, 1983

SECTION 2 (Continued)

Cross references of corresponding methods in FED. Test Method Std. No. 101A and 101B and 101C relative to the old 3 digit number of 101A and to new 4 digit number of 101B and 101C.

101A Method No.	101B Method No.	101C Method No.	Superseding ASTM Method No.
262	3017	Deleted	
263	4020	Deleted	
264	5026	Deleted	
265	2030	Superseded	D 3499, D 3500, D 3501, D 3502, D 3503
266	3019	Deleted	
267	4025	Deleted	
268	3024	Deleted	
269	3023	Deleted	
270	3022	Superseded	D 779
271	4037	Deleted	
272	4038	Deleted	
273	4041	Deleted	
274	3025	Deleted	
275	4042	Deleted	
276	4044	Deleted	
277	4045	Superseded	D 1003
278	5019	5019.1	
279	5020	5020.1	
280	4032	Superseded	D 1545, D 562
281	4033	Deleted	
282	4034	4034	
283	4035	Deleted	
284	4036	Superseded	D 570
285	3027	3027	
286	3030	3030.1	
287	4001	Superseded	*D 4157, *D 4158
288	6009	Deleted	
289	4003	Deleted	
290	4004	4004	
291	4005	Superseded	D 1894
292	2008	Superseded	F 36
293	2009	Deleted	
294	2010	Deleted	
295	5003	Superseded	D 642
296	2011	Deleted	
297	2012	Superseded	D 695
298	4007	Deleted	
299	3007	Deleted	
300	2013	Superseded	D 2221

\*Comparable test methods; not DOD adopted.

Supersedes page 11 of September 12, 1983

SECTION 2 (Continued)

Cross references of corresponding methods in FED. Test Method Std. No. 101A and 101B and 101C relative to the old 3 digit number of 101A and to new 4 digit number of 101B and 101C.

101A Method No.	101B Method No.	101C Method No.	Superseding ASTM Method No.
301	4008	Deleted	
302	5006	Deleted	
303	4009	Superseded	D 1531
304	2016	Deleted	
305	3010	Deleted	
306	3014	Superseded	D 568
307	4012	Superseded	D 1310
308	2017	2017.1	
309	2018	Superseded	D 1098
310	2019	Superseded	D 790
311	2020	Superseded	D 3499, D 3500, D 3501, D 3502, D 3503
312	2021	Superseded	D 1037
313	2025	Deleted	
314	5010	Deleted	
315	4016	Deleted	
316	1002	Deleted	
317	4017	Superseded	*D 87
318	6014	Deleted	
319	5025	Superseded	D 2016
320	4023	Superseded	C 148
321	2032	Superseded	D 781
322	4026	Superseded	B 117
323	4027	Deleted	
324	6020	Superseded	D 549
325	4039	Deleted	
326	2035	Deleted	
327	2036	Superseded	*Tappi T 414
328	2046	Superseded	D 1004
329	3026	Deleted	
330	6021	Superseded	A 90
331	6022	Deleted	
332	1003	1003.2	
333	3031	Deleted	
334	Deleted	Deleted	
335	5002	Deleted	
336	Deleted	Deleted	
337	3002	Deleted	
338	3005	3005	
339	3006	Deleted	

\* Comparable test method; not DoD adopted

Supersedes page 12 of September 12, 1983

SECTION 2 (Continued)

Cross references of corresponding methods in FED. Test Method Std. No. 101A and 101B and 101C relative to the old 3 digit number of 101A and to new 4 digit number of 101B and 101C.

101A Method No.	101B Method No.	101C Method No.	Superseding ASTM Method No.
340	2028	Deleted	
341	3004	Deleted	
342	Deleted	Deleted	
343	Deleted	Deleted	
344	4031	4031	
345	3028	3028	
346	Deleted	Deleted	
347	4046	4046.1	
348	2033	Superseded	*D 2808
349	Deleted	Deleted	

Cross references of corresponding methods in Fed. Test Method Std. No. 101C, 101B and 101A relative to the new 4 digit number of 101B and 101C to the old 3 digit number of 101A.

101C Method No.	Superseding ASTM Method No.	101B Method No.	101A Method No.
1001 Deleted		1001	238
1002 Deleted		1002	316
1003.2		1003	332
1004 Superseded	D 3652	--	--
2001 Deleted		2001	160
2002 Deleted		2002	255
2003 Deleted		2003	244
2004 Deleted		2004	162
2005 Deleted		2005	230
2006 Deleted		2006	231
2007.1		2007	250
2008 Superseded	F 36	2008	292
2009 Deleted		2009	293
2010 Deleted		2010	294
2011 Deleted		2011	296
2012 Superseded	D 695	2012	297
2013.1 Superseded	D 2221	2013	300
2014 Deleted		2014	165
2015.1		2015	183
2016 Deleted		2016	304
2017.1 Changed		2017	308
2018 Superseded	D 1098	2018	309

\* Comparable test method; not DOD adopted  
Supersedes page 13 of September 12, 1983

SECTION 2 (Continued)

Cross references of corresponding methods in Fed. Test Method Std. No. 101C, 101B and 101A relative to the new 4 digit number of 101B and 101C to the old 3 digit number of 101A.

101C Method No.	Superseding ASTM Method No.	101B Method No.	101A Method No.
2019 Superseded	D 790	2019	310
2020 Superseded	D 3499, D 3500, D 3501, D 3502, D 3503	2020	311
2021 Superseded	D 1037	2021	312
2022 Superseded	D 1238	2022	170
2023 Deleted		2023	242
2024 Deleted		2024	259
2025 Deleted		2025	313
2027 Deleted		2027	110
2028 Deleted		2028	340
2029 Deleted		2029	155
2030 Superseded	D 3499, D 3500, D 3501, D 3502, D 3503	2030	265
2031 Deleted		2031	112
2032 Superseded	*Tappi T 803	2032	321
2033 Superseded	*D 2808	2033	348
2034 Deleted		2034	234
2035.1 Deleted		2035	326
2036.1 Superseded	*Tappi T 414	2036	327
2037 Deleted**		2037	248
2038 Deleted		2038	246
2039 Deleted		2039	247
2040 Superseded	D 638	2040	245
2041 Deleted		2041	225
2042 Deleted		2042	228
2043 Deleted		2043	224
2044 Superseded	*D 3953	2044	227
2045 Deleted		2045	226
2046.1 Superseded	D 1004	2046	328
2047 Deleted		2047	218
2048 Deleted		2048	107
2049 Deleted		2049	158
2050 Superseded	D 3330		
2051 Superseded	D 3889		
2052 Deleted			
2053 Superseded	D 3813		
2054 Superseded	D 3654		
2055 Superseded	D 3654		
2056 Deleted			

\* Comparable test method; not DOD adopted

\*\* Use FED-STD-191, Methods 5100 or 5102, as applicable  
Supersedes page 14 of September 12, 1983

SECTION 2 (Continued)

Cross references of corresponding methods in Fed. Test Method Std. No. 101C, 101B and 101A relative to the new 4 digit number of 101B and 101C to the old 3 digit number of 101A.

101C Method No.	Superseding ASTM Method No.	101B Method No.	101A Method No.
2057 Deleted			
2058 Superseded	D 3662		
2059 Deleted			
2060 Deleted			
2061 Superseded	D 3759		
2062 Superseded	D 3759		
2063 Superseded	D 3759		
2064 Superseded	D 3811		
2065.1			
2071 Deleted			
3001 Deleted		3001	254
3002 Deleted		3002	337
3003		3003	223
3004 Deleted		3004	341
3005		3005	338
3006 Deleted		3006	339
3007 Deleted		3007	299
3008 Deleted		3008	229
3009 Deleted		3009	192
3010 Deleted		3010	305
3011 Deleted		3011	163
3013 Deleted		3013	167
3014.1 Superseded	D 568	3014.1	306
3015.1 Changed		3015	260
3016 Deleted		3016	261
3017 Deleted		3017	262
3018 Deleted		3018	187
3019.1 Deleted		3019	266
3020 Deleted		3020	233
3021 Deleted		3021	125
3022 Superseded	D 779	3022	270
3023 Deleted		3023	269
3024 Deleted		3024	268
3025 Deleted		3025	274
3026 Deleted		3026	329
3027		3027	285
3028		3028	345
3029 Superseded	D 724	3029	106
3030.1		3030	286

FED. TEST METHOD STD. NO. 101C  
 MARCH 13, 1980  
 CHANGE NOTICE 3  
 14 OCTOBER 1988

SECTION 2 (Continued)

Cross references of corresponding methods in Fed. Test Method Std. No. 101C, 101B and 101A relative to the new 4 digit number of 101B and 101C to the old 3 digit number of 101A.

101C Method No.	Superseding ASTM Method No.	101B Method No.	101A Method No.
3031 Deleted		3031	333
3032 Supeseded	D 3816		
3033 Superseded	D 3833		
4001 Superseded	*D 4157, *D 4158	4001	287
4002 Deleted		4002	219
4003 Deleted		4003	289
4004		4004	290
4005 Superseded	D 1894	4005	291
4006 Deleted		4006	256
4007.1 Deleted		4007	298
4008 Deleted		4008	301
4009 Superseded	D 1531	4009	303
4010 Deleted		4010	222
4011 Deleted		4011	257
4012 Superseded	D 1310	4012	307
4013 Deleted		4013	177
4014 Deleted		4014	235
4015 Deleted		4015	131
4016 Deleted		4016	315
4017 Superseded	*D 87	4017	317
4018 Superseded	E 462, E 619	4018	220
4019 Deleted		4019	174
4020 Deleted		4020	263
4023 Superseded	C 148	4023	320
4024 Deleted		4024	173
4025 Deleted		4025	267
4026 Superseded	B 117	4026	322
4027 Deleted		4027	323
4029 Deleted		4029	123
4030 Deleted		4030	134
4031		4031	344
4032 Superseded	D 1545, D 562	4032	280
4033 Deleted		4033	281
4034		4034	282
4035 Deleted		4035	283
4036 Superseded	D 570	4036	284
4037 Deleted		4037	271
4038 Deleted		4038	272
4039 Deleted		4039	325

\* Comparable test methods; not DOD adopted  
 Supersedes page 16 of September 12, 1983

SECTION 2 (Continued)

Cross references of corresponding methods in Fed. Test Method Std. No. 101C, 101B and 101A relative to the new 4 digit number of 101B and 101C to the old 3 digit number of 101A.

101C Method No.	Superseding ASTM Method No.	101B Method No.	101A Method No.
4040 Deleted		4040	133
4041 Deleted		4041	273
4042 Deleted		4042	275
4043 Superseded	C 177	4043	185
4044 Deleted		4044	276
4045 Superseded	D 1003	4045	277
4046.1		4046	347
4047 Superseded	D 3611		
4048 Deleted			
4049 Deleted			
4050 Superseded	D 3815		
5001 Deleted		5001	217
5002 Deleted		5002	335
5003 Superseded	D 642	5003	295
5004 Deleted		5004	168
5005.1		5005	214
5006 Deleted		5006	302
5007.1		5007	216
5008.1		5008	213
5009.2 Changed		5009	241
5010 Deleted		5010	314
5011.1		5011	236
5012		5012	212
5013 Deleted	*D 782	5013	243
5014		5014	240
5015 Deleted		5015	239
5016.1		5016	209
5017		5017	210
5018		5018	215
5019.1		5019	278
5020.1		5020	279
5021 Superseded	D 1008, D 895,	5021	252
5022.1	*Tappi T 410	5022	204
5023		5023	211
5024 Deleted	*Tappi T 400, T 412, T 484	5024	205
5025 Superseded	D 2016	5025	319
5026 Deleted		5026	264
5027 Deleted		5027	208
6001 Deleted		6001	253

\* Comparable test method; not DOD adopted  
Supersedes page 17 of September 12, 1983



FED. TEST METHOD STD. NO. 101C  
MARCH 13, 1980  
CHANGE NOTICE 3  
14 OCTOBER 1988

SECTION 2 (Continued)

Cross references of corresponding methods in Fed. Test Method Std. No. 101C, 101B and 101A relative to the new 4 digit number of 101B and 101C to the old 3 digit number of 101A.

101C Method No.	Superseding ASTM Method No.	101B Method No.	101A Method No.
6002 Deleted		6002	203
6003 Deleted		6003	129
6004 Deleted		6004	135
6005 Deleted		6005	206
6006 Deleted		6006	207
6007 Deleted		6007	126
6009 Deleted		6009	288
6010 Deleted		6010	144
6011.1 Deleted		6011	237
6012 Deleted		6012	157
6013 Superseded	D 1030	6013	249
6014 Deleted		6014	318
6017 Deleted		6017	221
6018 Deleted		6018	232
6019 Deleted		6019	251
6020 Superseded	D 549	6020	324
6021 Superseded	A 90	6021	330
6022 Deleted		6022	331
6023 Deleted		6023	349

Supersedes page 18 of September 12, 1983

SECTION 3

ALPHABETICAL INDEX OF TEST METHODS

Title	101C Method No.	Superseding ASTM Method No.
Abrasion Test .....	Superseded	*D 4157, *D 4158
Abrasive, Test for .....	Deleted	
Absorption of Rust-Preventive Compound by Wood ...	Deleted	
Absorption of Water Vapor and Dimensional Change in Packaging Materials .....	Deleted	
Absorption (Penetration) Test of Ink, Paint, etc .	Deleted	
Accelerated Aging of Pressure-Sensitive Packaging Tapes (Heat and Humidity, or Heat Only) .....	Superseded	D 3611
Acidity, Alkalinity, and Hydrogen Ion Concentration (pH) .....	Deleted	
Activity of Synthetic Detergent in Cleaning Compound .....	Deleted	
Adhesion of Barrier Materials .....	Deleted	
Adhesion of Fabrics, Coated and Laminated .....	Deleted	
Adhesion of Labels .....	Deleted	
Adhesion of Pressure-Sensitive Tapes .....	Superseded	D 3330
Adhesion of Pressure-Sensitive Tapes to Paper at Low Temperature .....	Superseded	D 3889
Adhesion Strength: Primer-Sensitive Tape .....	Deleted	
Adhesiveness of Gummed Paper Tapes to Paper .....	Deleted	
Adhesive Shear Test of Glued Lap Joints in Packaging Materials .....	Deleted	
Adsorption Capacity of Desiccant in Bags .....	Deleted	
Analytical Tests for Barrier Material, Coating Compound, Strippable, (Sprayable) .....	Deleted	
Appearance and Pour Compounds .....	Deleted	
Ash and Loss on Ignition of Solid Materials .....	Deleted	
Ash Content of Liquid Samples .....	Deleted	
Asphalt Content of Paper, Asphalt Impregnated ...	Deleted	
Asphalt Content of Paper, Duplex, and Asphalt Impregnated .....	Deleted	
Assembly and Disassembly Test of Containers or Complete Packs .....	Deleted	
Basis Weight of Paper and Asphalt in Barrier Material .....	Deleted	
Basis Weight of Paper and Paperboard .....	5022.1	*Tappi T 410
Bending Test of Packaging Materials .....	Deleted	
Bleeding of Packaging Materials .....	Deleted	
Bleed-Through or Smearing .....	Deleted	
Blocking Resistance of Packaging Materials .....	3003	
Boiling Nitric Acid Test .....	Deleted	
Boiling Test of Bottles, Gas .....	Deleted	

\* Comparable test method, not DOD adopted  
Supersedes page 19 of September 12, 1983

ALPHABETICAL INDEX OF TEST METHODS (Continued)

Title	101C Method No.	Superseding ASTM Method No.
Bonding Range: Primer, Pressure-Sensitive Tape .....	Deleted	
Bridging Qualities of Cocooning Materials .....	Deleted	
Brittleness of Nonstrippable Coatings (Knife Test) .....	Deleted	
Brittleness of Strippable Coating Compounds .....	Deleted	
Brushing Properties .....	Deleted	
Bursting Strength of Corrugated and Solid Fiberboard .....	Deleted	
Bursting Strength of Paper, Linerboard, Corrugated and Solid Fiberboard .....	Deleted	
Bursting Strength of Sheet Materials .....	2007.1	
Cap Seal Test for Drums, Steel .....	Deleted	
Cleanliness .....	4004	
Cleanliness Degradation of Critically Clean Products in Packages .....	Deleted	
Closure of Fiber Containers for Power and Explosives .....	Deleted	
Closure Test of Drums, Steel .....	Deleted	
Coating Weight of Thickness of Coating, Exterior for Tinned Food Cans .....	Deleted	
Coefficient of Friction of Film (Slip) .....	Superseded	D 1894
Cohesion, Low Temperature, of Compound, Dipcoat Sealing .....	Deleted	
Color and Sensitivity of Spots on Card Indicator, Humidity .....	Deleted	
Color Test for Humidity Indicators .....	Deleted	
Compatibility Test of Materials .....	Deleted	
Compressibility and Recovery Test for Gasket Materials .....	Superseded	F 36
Compression Set After Constant Deformation .....	Deleted	
Compression Set After Cycling .....	Deleted	
Compression Test for Shipping Containers .....	Superseded	D 642
Compressive Force-Displacement Characteristics of Cushioning Materials .....	Deleted	
Compressive Properties of Rigid Plastics .....	Superseded	D 695
Conditioning (Environments and Exposures) .....	Deleted	
Conditioning of Paper .....	Deleted	
Contact Corrosivity Test of Solid Materials in Flexible, Rigid, or Granular Forms .....	3005	
Continuity of Nonconductive Lining of a Metal Container .....	Deleted	

Supersedes page 20 of September 12, 1983

ALPHABETICAL INDEX OF TEST METHODS (Continued)

Title	101C Method No.	Superseding ASTM Method No.
Contraction on Solidification of Compound, Sealing, Dipcoating .....	Deleted	
Cornerwise-Drop (Rotational) Test .....	5005.1	
Corrosion Inhibiting Ability of V.C.I. Vapors ....	4031	
Corrosion Resistance Test of Coatings .....	Deleted	
Corrosion Test of Container Components .....	Deleted	
Creep Properties of Package Cushioning Materials Under Compression .....	Superseded	D 2221
Creep Properties of Pressure-Sensitive Plastic Film Tape .....	Deleted	
Curling and Twisting on Unwind or Pressure- Sensitive Tapes .....	Superseded	D 3813
Curling and Twisting Tendencies of Barrier Materials .....	2015.1	
Density and Specific Gravity .....	Deleted	
Dent Resistance .....	Deleted	
Deterioration Resistance of Materials in Soil ....	Deleted	
Determination of Gaseous Oxygen in Hermetically Sealed Containers .....	Deleted	
Determining Effectiveness of Descaling Process Applied to Steel Drums .....	Deleted	
Dielectric Constant and Dissipation Factor .....	Superseded	D 1531
Dilution of Compound, Waterproofing .....	Deleted	
Drop Test (Free Fall) .....	5007.1	
Drying Time Test .....	Deleted	
Ductility (Cupping) .....	Deleted	
Durability of Bags With Activated Desiccants .....	Deleted	
Dust Forming Characteristics of Cleaning Compound, Alkali Type .....	Deleted	
Dustiness .....	Deleted	
Dye, Identification, of Compound, Corrosion- Preventive .....	Deleted	
Edgewise-Drop (Rotational) Test .....	5008.1	
Effect of a Preservative Compound on the Color- Indicating Property of Cobalt Chloride Impregnated Desiccant .....	Deleted	
Effect of Protective Coatings in Painted Surfaces .....	Deleted	
Electrostatic Properties of Metal .....	4046.1	
Etching Properties of Metal Conditioners .....	Deleted	
Examination for Compatibility of Containers for Liquids With Their Contents .....	Deleted	
Exudation of Strippable Protective Compounds .....	Deleted	

Supersedes page 21 of September 12, 1983

ALPHABETICAL INDEX OF TEST METHODS (Continued)

Title	101C Method No.	Superseding ASTM Method No.
Fiber Identification and Content .....	Superseded	D 1030
Filling Plug Clearance of Can, Gasoline .....	Deleted	
Fingerprint Suppression of Compound, Corrosive- Preventive, Fingerprint Remover .....	Deleted	
Fit of Covers on Telescope-Style Containers .....	Deleted	
Flammability of Flexible Barrier Material .....	Superseded	D 568
Flash and Fire Point Tests (Flammability) .....	Superseded	D 1310
Flat Crush of Corrugated Fiberboard .....	Deleted	
Flexing Procedure for Barrier Materials .....	2017.1	
Flexural Properties of Corrugated Paperboard .....	Superseded	D 1098
Flexural Properties of Plastics .....	Superseded	D 790
Flexural Properties of Veneer, Paper-Overlaid Veneer, Plywood and Other Glued Veneer Constructions .....	Superseded	D 3499, D 3500, D 3501, D 3502, D 3503
Flexural Properties of Wood-Base Fiber and Particle Panel Materials .....	Superseded	D 1037
Flow Rate (Melt Index) of Thermoplastics Including Polyethylene, Polypropylene, Polystyrene, Nylon, etc .....	Superseded	D 1238
Foaming Separation Properties of Metal Conditioners .....	Deleted	
Folding Endurance Test .....	Deleted	
Free Alkali Present in Wax Emulsions (Rust Inhibiting) .....	Deleted	
Gumminess of Oil, Lubricating, Preservative .....	Deleted	
Hardness .....	Deleted	
Heat Resistance of Fabric for Waterproof Bags ....	Deleted	
Heat-Sealed Seam Test .....	2024	
Holding Power of Pressure-Sensitive Tapes .....	Superseded	D 3654
Holding Power Test for Filament (Lineally and Multi-Directional) Tapes .....	Superseded	D 3654
Humidity Control by Desiccant .....	Deleted	
Impact Puncture Resistance of Films and Barriers .	Deleted	
Impact Resistance of Polyethylene Films by Free Falling Dart Method .....	Deleted	
Impact Resistance Test for Filament (Lineally and Multi-Directional) Reinforced Tapes .....	Deleted	
Incline-Impact Test .....	5023	
Joint Test (Metal End to Fiber Tube) .....	Deleted	
Knife Test of Compound, Waterproofing .....	Deleted	
Lateral-Resistance Test for Fasteners .....	Deleted	

Supersedes page 22 of September 12, 1983

ALPHABETICAL INDEX OF TEST METHODS (Continued)

Title	101C Method No.	Superseding ASTM Method No.
Leakage of Gaskets for Floating Bag Barriers .....	Deleted	
Leakage Resistance of Disposable Bags .....	Deleted	
Leaks in Containers .....	5009.2	
Liquid Capacity and Outage of Containers for Liquids .....	Deleted	
Load Deflection Characteristics of Resilient Cushioning Materials (Static Indentation Method) .....	Deleted	
Loss-on-Ignition of Dynamic Dehumidification Desiccants .....	Deleted	
Low Temperature Flexibility of Asphalt Laminated Textile and Paper Material .....	Deleted	
Marking Characteristics of Ink .....	Deleted	
Measurement of Length and Width of Specimens of Cushioning Materials .....	Deleted	
Mechanical Handling Test .....	5011.1	
Melting Point of Wax .....	Superseded	*D 87
Moisture Content of Barrier Material, Grease-proofed Flexible .....	Deleted	
Moisture Content of Desiccant .....	Deleted	
Moisture Content of Paper and Paperboard .....	Deleted	*Tappi T 400, T 412, T 484 D 2016
Moisture Content of Wood .....	Superseded	
Moisture Retention of Fiberboard, Solid, Dunnage	Deleted	
Neutralization, Hydrobromic Acid, on Corrosion-Preventive Compounds .....	Deleted	
Nonvolatile Content Test .....	Deleted	
Odor Test .....	Superseded	E 46, E 619
Oil Film (Slick) of Compound, Corrosion-Preventive .....	Deleted	
Oil Resistance of Heat-Sealable Films and Barriers .....	3015.2	
Oil Resistance of Pressure-Sensitive Tapes .....	Deleted	
Oil Transmission Test for Packaging Materials ....	Deleted	
Opacity .....	Deleted	
Opacity of Thin Sheets .....	Deleted	
Opacity (Photometer or Densitometer Method) .....	Deleted	
Organic Solvent in Rust Removing Compounds .....	Deleted	
Outage of Bottles and Carboys .....	Deleted	
Oxidation Substances in Tricresyl Phosphate Used in Oil, Hydraulic Preservative .....	Deleted	
Package Cushioning Materials Testing .....	Deleted	
Paintability, Drying Time, and Surface Deposits of Wood Preservative, Water Repellent .....	Deleted	
Paraffin in Paper (Wax Content) .....	Deleted	
Pendulum-Impact Test .....	5012	

\* Comparable test methods; not DOD adopted  
Supersedes page 23 of September 12, 1983

ALPHABETICAL INDEX OF TEST METHODS (Continued)

Title	101C Method No.	Superseding ASTM Method No.
Penetration of Packaging Materials by Water .....	Deleted	
Penetration Test of Water Repellent Wood Preservative .....	Deleted	
Performance of a Package Window Assembly in a Flexible Barrier Material .....	Deleted	
Performance of Indicator, Corrosion Control .....	Deleted	
Permanency of Marking of Ampoules, Glass, Flame-Sealed .....	Deleted	
Phenols, Free, in Tricresyl Phosphate Used in Oil, Hydraulic, Preservation .....	Deleted	
Phosphite in Tricresyl Phosphate Used in Oil, Hydraulic, Preservative .....	Deleted	
Pigments and Lead Content of Pigments in Compounds, Rust-Preventive .....	Deleted	
Plasticity and Recovery of Strippable Preservative Compounds .....	Deleted	
Pliability of Barrier Material .....	Deleted	
Plywood Glue Shear Test .....	Superseded	D 3499, D 3500, D 3501, D 3502, D 3503
Polariscopic Examination for Annealing of Glass ..	Superseded	C 148
Preservative Retention of Preservative Compounds .	Deleted	
Puncture Resistance .....	2031	
Puncture Resistance and Elongation Test (1/8 Inch Radius Probe Method) .....	2065.1	
Puncture Resistance (Beach, or G.E., Test) .....	Superseded	*Tappi T 803
Puncture Resistance of Fiberboard Drums .....	Deleted	
Qualitative Determination of Copper Content of Paper or Paperboard .....	Deleted	
Rate of Penetration of Packaging Materials by Water .....	Deleted	
Reflectance .....	Deleted	
Resistance to Creep of Pressure-Sensitive Plastic-Backed Tapes .....	Deleted	
Resistance of Packaging Materials to Fungi .....	Deleted	
Resistance of the Coating of Steel Shipping Pails to Liquids .....	Deleted	
Resistance of Sheet Materials to Penetration by Water .....	Superseded	D 779
Resistance to Boiling Water .....	Deleted	
Resistance to Color Bleeding of Barrier Material, Waterproof, Flexible .....	Deleted	
Revolving Hexagonal Drum Test .....	Deleted	
Rollover Test .....	5014	

\*Comparable test methods; not DOD adopted.

Supersedes page 24 of September 12, 1983

ALPHABETICAL INDEX OF TEST METHODS (Continued)

Title	101C Method No.	Superseding ASTM Method No.
Rust Removability (Metal Conditioning) Properties of Corrosion Preventive Compound, Oil, Metal Conditioning .....	Deleted	
Salt Spray Test .....	Superseded	B 117
Sedimentation in Compounds .....	Deleted	
Self-Heating .....	Deleted	
Sensitivity of Photographic Film to Packaging Materials .....	Deleted	
Shear Strength of Water Resistant Adhesive .....	Deleted	
Shear Strength-Plywood, Metal-Bonded .....	Deleted	
Shipping Test .....	Deleted	
Shock Test Bottles, Glass .....	Deleted	
Short Column Test of Corrugated Fiberboard in the Cross-Machine Direction .....	Superseded	*D 2808
Shrinkage of Pressure-Sensitive Tape .....	Deleted	
Shrinkage of Tapes With Plastic Backing .....	Deleted	
Silver-Tarnishing Test .....	Deleted	
Size of Desiccant Particles .....	Deleted	
Sizing (Rosin) in Paper and Paperboard .....	Superseded	D 549
Sludging of Wood Preservative .....	Deleted	
Softening Point of Compound, Sealing, Dipcoating .	Deleted	
Solubility in Oil of Compounds, Corrosion Preventive .....	Deleted	
Solubility of Solid Substance in Water and Organic Solvents .....	Deleted	
Solubility of Wax, Petroleum .....	Deleted	
Solvent Content of Cleaning Compound .....	Deleted	
Specular Gloss .....	Deleted	
Spot Test of Naphtha, Aliphatic .....	Deleted	
Spot Weld Strength of Cans .....	Deleted	
Sprayability and Delivery Rate .....	Deleted	
Sprayability of Coating Compounds .....	Deleted	
Springback (Fold Retention) .....	Deleted	
Strain Test for Compounds, Corrosion Preventive ..	Deleted	
Stiffness (Bending Resistance) of Wrapping Material .....	Deleted	
Strength of Desiccant Particles .....	Deleted	
Strength of Tape Backing: Diaphragm Bursting Method .....	Superseded	D 3662
Strippability of Coating Materials .....	Deleted	
Stripping Metal End, of Fiber Tubes and Cans .....	Deleted	
Submersion Test of Materials for Absorption of Liquid and Dimensional Stability .....	Deleted	
Superimposed-Load Test (Stackability, With Dunnage) .....	5016.1	

\* Comparable test method; not DOD adopted  
Supersedes page 24A, September 12, 1983



ALPHABETICAL INDEX OF TEST METHODS (Continued)

Title	101C Method No.	Superseding ASTM Method No.
Superimposed-Load Test (Uniformly Distributed, Without Dunnage) .....	5017	
Surface Condition of Dry-Annealed Aluminum Foil ..	Deleted	
Surface Wax in Paper .....	Deleted	
Tearing Resistance (Elmendorf) .....	Superseded	*Tappi T 414
Tearing Resistance (Internal) of Tapes .....	Deleted	
Tearing Resistance of Tapes With Plastic Backing ..	Deleted	
Tensile Breaking Strength and Elongation of Cloth, Coated Cloth, and Similar Sheet Materials .....	Deleted**	
Tensile Breaking Strength and Elongation of Paper and Paperboard .....	2038	
Tensile Breaking Strength and Elongation of Thread, Twine, and Small Cords .....	Deleted	
Tensile Properties of Plastics .....	Superseded	D 638
Tensile Properties of Pressure-Sensitive Tapes ...	Deleted	
Tensile Strength (Breaking Strength) and Elongation and Filament (Lineally and Multi-Directional) Reinforced Pressure-Sensitive Tapes .....	Superseded	D 3759
Tensile Strength (Breaking Strength) and Elongation of Pressure-Sensitive Tapes (Other Than Filament (Lineally and Multi-Directional) Reinforced .....	Superseded	D 3759
Tensile Strength (Breaking Strength), Elongation, and Stretch Force of Pressure-Sensitive Tapes ..	Superseded	D 3759
Tensile Strength (Minimum) of Cushioning Material for Packaging .....	Deleted	
Tensile Strength of Strapping (With or Without Joints) .....	Superseded	*D 3953
Tensile Strength and Ultimate Elongation of Soft Vulcanized Rubber Compounds and Similar Rubber-Like Materials .....	Deleted	
Tensile Strength, Yield Point, and Elongation of Sheet Steel for Containers .....	Deleted	
Tensile Tear Test of Plastic Film and Thin Sheet ..	Superseded	D 1004
Test for Cracking Caused by Protective Organic Coatings .....	Deleted	
Test for Quality of Glue Applications .....	Deleted	
Test for Quantity of Zinc Coating .....	Superseded	A 90
Test for Weight of Phosphate Coating .....	Deleted	
Thermal Conductivity of Cushioning Material .....	Superseded	C 177
Thermal Shock Test .....	Deleted	
Thickness Measurements of Nonrigid Specimens .....	1003.2	

\*Comparable test methods; not DOD adopted.

\*\* Use FED-STD-191, Methods 5100 or 5102 as applicable  
Supersedes page 24B, September 12, 1983

ALPHABETICAL INDEX OF TEST METHODS (Continued)

Title	101C Method No.	Superseding ASTM Method No.
Thickness of Tapes .....	Superseded	D 3652
Tipover Test .....	5018	
Torque Test-Container, Spirally Wound .....	Deleted	
Torsion Test for Internally Threaded Collars or Flanges (for Plug Closures) Attached to Drums or Cans .....	Deleted	
Torsion Test for Threads of Protective Caps and Plugs .....	Deleted	
Total Luminous Transmittance .....	Superseded	D 1003
Unit Weight and Absorption Capacity of Desiccants .....	Deleted	
Unrolling Properties of Pressure-Sensitive Tape ..	Deleted	
Unwind Pressure-Sensitive Tapes .....	Superseded	D 3811
Vacuum Retention of Packages .....	Deleted*	
Vibration (Repetitive Shock) Test .....	5019.1	
Vibration (Sinusoidal Motion) Test .....	5020.1	
Vibratory Flexing Properties of Barrier Materials ..	Deleted	
Viscosity Test .....	Superseded	D 1545, D 562
Visual Examination for Color, Color Fasteners, and Gloss .....	Deleted	
Visual Examination for Transparency or Opacity ...	4034	
Volume of a Desiccant Unit .....	Deleted	
Water Absorption by Cushioning Materials .....	Deleted	
Water Absorption Test of Plastics (Other Than Cushioning Materials) .....	Superseded	D 570
Water Repellency of Wood Preservative .....	Deleted	
Water Resistance of Markings .....	3027	
Water Resistance of Packaging Materials (Ply Separation) .....	3028	
Water Run-Off Test of Paper .....	Superseded	D 724
Water-Penetration Rate Off Pressure-Sensitive Tapes .....	Superseded	D 3816
Water Solubility of Pressure-Sensitive Tapes .....	Deleted	
Water Vapor Permeability Test of Containers or Packages .....	Superseded	D 1008, D 895
Water Vapor Permeability Test of Packaging Materials (Water Vapor Transmission Rate Test) ..	3030.1	
Water-Vapor Transmission Rate of Pressure-Sensitive Tapes .....	Superseded	D 3883
Wax Transfer of Paper .....	Deleted	
Weatherometer Aging of Pressure-Sensitive Tapes ..	Superseded	D 3815
Workability of Coating Material After Application ..	Deleted	
Working Properties of Compound, Non-Oxidizing, Rust-Preventive .....	Deleted	

\*Incorporated in Test Method 5009.1, Leaks in Containers

Supersedes page 24C, September 12, 1983

FED. TEST METHOD STD. NO. 101C  
MARCH 13, 1980  
CHANGE NOTICE 3  
14 OCTOBER 1988

THIS PAGE INTENTIONALLY LEFT BLANK

Added page 24D, September 12, 1983

SECTION 4

NUMERICAL INDEX OF TEST METHODS

1000 Group-Dimensional Measurements

101C Method No.	Superseding ASTM Method No.	Title
1001 Deleted		Fit of Covers on Telescope-Style Containers
1002 Deleted		Measurement of Length and Width of Specimens of Cushioning Materials
1003.2		Thickness Measurements of Nonrigid Specimens
1004 Superseded	D 3652	Thickness of Tapes

2000 Group-Strength and Elastic Properties of Materials

101C Method No.	Superseding ASTM Method No.	Title
2001 Deleted		Adhesion of Barrier Materials
2002 Deleted		Adhesive Shear Test of Glued Lap Joints in Packaging Materials
2003 Deleted		Bending Test of Packaging Materials
2004 Deleted		Bridging Qualities of Cocooning Materials
2005 Deleted		Brittleness of Nonstrippable Coatings (Knife Test)
2006 Deleted		Brittleness of Strippable Coating Compounds
2007.1		Bursting Strength of Sheet Materials
2008 Superseded	F 36	Compressibility and Recovery Test for Gasket Material
2009 Deleted		Compression Set After Constant Deformation
2010 Deleted		Compression Set After Cycling
2011 Deleted		Compressive Force-Displacement Character- istics of Cushioning Materials
2012 Superseded	D 695	Compressive Properties of Rigid Plastics
2013.1 Superseded	D 2221	Creep Properties of Package Cushioning Materials Under Compression
2015.1		Curling and Twisting Tendencies of Barrier Materials
2017.1		Flexing Procedure for Barrier Materials
2018 Superseded	D 1098	Flexural Properties of Corrugated Paperboard
2019 Superseded	D 790	Flexural Properties of Plastics
2020 Superseded	D 3499, D 3500, D 3501, D 3502, D 3503	Flexural Properties of Veneer, Paper Overlaid Veneer, Plywood, and Other Glued Veneer Constructions

FED. TEST METHOD STD. NO. 101C  
MARCH 13, 1980  
CHANGE NOTICE 3  
14 OCTOBER 1988

NUMERICAL INDEX OF TEST METHODS (Continued)

2000 Group—Strength and Elastic Properties of Materials

101C Method No.	Superseding ASTM Method No.	Title
2021 Superseded	D 1037	Flexural Properties of Wood-Base Fiber and Particle Panel Materials
2022 Superseded	D 1238	Flow Rate (Melt Index) of Thermoplastics Including Polyethylene, Polypropylene, Polystyrene, Nylon, etc.
2023 Deleted		Folding Endurance Test
2024 Deleted		Heat-Sealed Seam Test
2025 Deleted		Impact Puncture Resistance of Films and Barriers
2027 Deleted		Lateral-Resistance Test for Fasteners
2028 Deleted		Load Deflection Characteristics of Resilient Cushioning Materials (Static Indentation Method)
2029 Deleted		Plasticity and Recovery of Strippable Preservative Compounds
2030 Superseded	D 3499, D 3500, D 3501, D 3502, D 3503	Plywood Glue Shear Test
2031 Deleted		Puncture Resistance
2032 Superseded	D 781	Puncture Resistance (Beach, or G.E., Test)
2033 Superseded	*D 2808	Short Column Test of Corrugated Fiberboard in the Cross-Machine Direction
2034 Deleted		Springback (Fold Retention)
2035.1 Deleted		Stiffness (Bending Resistance) of Wrapping Material
2036.1 Superseded	D 689	Tearing Resistance (Elmendorf)
2037 Deleted		Tensile Breaking Strength and Elongation of Cloth, Coated Cloth, and Similar Sheet Materials
2038 Deleted		Tensile Breaking Strength and Elongation of Paper and Paperboard
2039 Deleted**		Tensile Breaking Strength and Elongation of Thread, Twine, and Small Cords
2040 Superseded	D 638	Tensile Properties of Plastics
2043 Deleted		Tensile Strength (Minimum) of Cushioning Material for Packaging
2044 Superseded	*D 3953	Tensile Strength of Strapping (With or Without Joints)
2045 Deleted		Tensile Strength, Yield Point, and Elongation of Sheet Steel for Containers

\* Comparable test method, not DOD adopted

\*\* Use FED-STD-191, Methods 5100 or 5102 as applicable  
Supersedes page 26 of September 12, 1983

NUMERICAL INDEX OF TEST METHODS (Continued)

2000 Group—Strength and Elastic Properties of Materials (Continued)

101C Method No.	Superseding ASTM Method No.	Title
2046.1 Superseded	D 1004	Tensile Tear Test of Plastic Film and Thin Sheet
2047 Deleted		Torsion Test for Threads of Protective Caps and Plugs
2049 Deleted		Vibratory Flexing Properties of Barrier Materials
2050 Superseded	D 3330	Adhesion of Pressure-Sensitive Tapes
2051 Superseded	D 3889	Adhesion of Pressure-Sensitive Tapes to Paper at Low Temperature
2052 Deleted		Adhesiveness of Gummed Paper Tapes to Paper
2053 Superseded	D 3813	Curling and Twisting on Unwind of Pressure-Sensitive Tapes
2054 Superseded	D 3654	Holding Power of Pressure-Sensitive Tapes
2055 Superseded	D 3654	Holding Power Test for Filament (Lineally and Multi-Directional) Tapes
2056 Deleted		Impact Resistance Test for Filament (Lineally and Multi-Directional) Reinforced Tapes
2057 Deleted		Resistance to Creep of Pressure-Sensitive Plastic-Backed Tapes
2058 Superseded	D 3662	Strength of Tape Backing: Diaphragm Bursting Method
2059 Deleted		Tearing Resistance (Internal) of Tapes
2060 Deleted		Tearing Resistance of Tapes With Plastic Backing
2061 Superseded	D 3759	Tensile Strength (Breaking Strength) and Elongation of Filament (Lineally and Multi-Directional) Reinforced Pressure-Sensitive Tapes
2062 Superseded	D 3759	Tensile Strength (Breaking Strength) and Elongation of Pressure-Sensitive Tapes (Other Than Filament (Lineally and Multi-Directional) Reinforced)
2063 Superseded	D 3759	Tensile Strength (Breaking Strength), Elongation, and Stretch Force of Pressure-Sensitive Tapes
2064 Superseded	D 3811	Unwind of Pressure-Sensitive Tapes
2065.1		Puncture Resistance and Elongation Test (1/8 Inch Radius Probe Method)
2071 Deleted		Pliability of Barrier Materials

NUMERICAL INDEX OF TEST METHODS (Continued)

3000 Group-Resistance Properties of Materials

101C Method No.	Superseding ASTM Method No.	Title
3001 Deleted		Absorption of Water and Dimensional Change in Packaging of Materials
3002 Deleted		Bleed-Through or Smearing
3003		Blocking Resistance of Packaging Materials
3004 Deleted		Compatibility Test of Materials
3005		Contact Corrosivity Test of Solid Materials in Flexible, Rigid, or Granular Forms
3006 Deleted		Corrosion Resistance Test of Coatings
3007 Deleted		Corrosion Test of Container Components
3009 Deleted		Effect of a Preservative Compound on the Color-Indicating Property of Cobalt Chloride Impregnated Desiccant
3010 Deleted		Effect of Protective Coatings on Painted Surfaces
3011 Deleted		Etching Properties of Metal Conditioners
3013 Deleted		Exudation of Strippable Protective Compounds
3014.1 Superseded	D 568	Flammability of Flexible Barrier Material
3015.2		Oil Resistance of Heat-Sealable Films and Barriers
3016 Deleted		Oil Resistance of Pressure-Sensitive Tapes
3017 Deleted		Oil Transmission Test for Packaging Materials
3018 Deleted		Performance of a Package Window Assembly in a Flexible Barrier Material
3019.1 Deleted		Rate of Penetration of Packaging Materials by Water
3020 Deleted		Resistance of Packaging Materials to Fungi
3021 Deleted		Examination for Compatibility of Containers for Liquids With Their Contents
3022 Superseded	D 779	Resistance of Sheet Materials to Penetration by Water
3023 Deleted		Resistance of the Coating of Steel Shipping Pails to Liquids
3025 Deleted		Submersion Test of Materials for Absorption of Liquid and Dimensional Stability
3027		Water Resistance of Markings
3028		Water Resistance of Packaging Materials (Ply Separation)
3029 Superseded	D 724	Water Run-Off Test of Paper
3030.1		Water Vapor Permeability Test of Packaging Materials (Water Vapor Transmission Rate Test)
3031 Deleted		Workability of Coating Material After Application
3032 Superseded	D 3816	Water-Penetration Rate of Pressure-Sensitive Tapes
3033 Superseded	D 3833	Watervapor Transmission Rate of Pressure-Sensitive Tapes

Supersedes page 28 of September 12, 1983

NUMERICAL INDEX OF TEST METHODS (Continued)

4000 Group-General Physical Properties

101C Method No.	Superseding ASTM Method No.	Title
4001 Superseded	*D 4157, *D4158	Abrasive, Test
4002 Deleted		Abrasive, Test for
4004 Deleted		Cleanliness
4005 Superseded	D 1894	Coefficients of Friction of Film (Slip)
4006 Deleted		Color Test for Humidity Indicators
4007.1 Deleted		Conditioning (Environments and Exposures)
4008 Deleted		Density and Specific Gravity
4009 Superseded	D 1531	Dielectric Constant and Dissipation Factor
4010 Deleted		Drying Time Test
4011 Deleted		Dustiness
4012 Superseded	D 1310	Flash and Fire Point Tests (Flammability)
4013 Deleted		Foaming and Separation Properties of Metal Conditioners
4014 Deleted		Hardness
4015 Deleted		Humidity Control by Desiccant
4016 Deleted		Marking Characteristics of Ink
4017 Superseded	*D 87	Melting Point of Wax
4018 Superseded	E 462, E 619	Odor Test
4019 Deleted		Opacity (Photometer or Densitometer Method)
4020 Deleted		Opacity
4023 Superseded	C 148	Polarscopic Examination for Annealing of Glass
4024 Deleted		Leakage of Gaskets for Floating Bag Barriers
4026 Superseded	B 117	Salt Spray Test
4030 Deleted		Size of Desiccant Particles
4031 Deleted		Corrosion Inhibiting Ability of V.C.I. Vapors
4032 Superseded	D 1545, D 562	Viscosity Test
4034 Deleted		Visual Examination for Transparency or Opacity
4035 Deleted		Water Absorption by Cushioning Materials
4036 Superseded	D 570	Water Absorption Test of Plastics (Other Than Cushioning Materials)
4039 Deleted		Sprayability and Delivery Rate
4040 Deleted		Strength of Desiccant Particles
4041 Deleted		Strippability of Coating Materials
4043 Superseded	C 177	Thermal Conductivity of Cushioning Materials
4044 Deleted		Thermal Shock Test
4045 Superseded	D 1003	Total Luminous Transmittance
4046.1 Deleted		Electrostatic Properties of Materials
4047 Superseded	D 3611	Accelerated Aging of Pressure-Sensitive Packaging Tapes (Heat and Humidity, or Heat Only)
4048 Deleted		Shrinkage of Tapes With Plastic Backing
4049 Deleted		Water Solubility of Pressure-Sensitive Tapes
4050 Superseded	D 3815	Weatherometer Aging of Pressure-Sensitive Tapes

\* Comparable test methods; not DOD adopted  
Supersedes page 29 of September 12, 1983



NUMERICAL INDEX OF TEST METHODS (Continued)

5000 Group-Properties of Containers, Packages, Packs,  
and Packaging Materials

101C Method No.	Superseding ASTM Method No.	Title
5001 Deleted		Assembly and Disassembly Test of Containers of Complete Packs
5002 Deleted		Cleanliness Degradation of Critically Clean Products in Packages 5003 Superseded
D 642		Compression Test for Shipping Containers
5005.1		Cornerwise-Drop (Rotational) Test
5006 Deleted		Dent Resistance
5007.1		Drop Test (Free Fall)
5008.1		Edgewise-Drop (Rotational) Test
5009.2		Leaks in Containers
5011.1		Mechanical Handling Test
5012		Pendulum-Impact Test
5013 Superseded	*D 782	Revolving Hexagonal Drum Test
5014		Rollover Test
5015 Deleted		Shipping Test
5016.1		Superimposed-Load Test (Stackability, With Dunnage)
5017		Superimposed-Load Test (Uniformly Distributed, Without Dunnage)
5018		Tipover Test
5019.1		Vibration (Repetitive Shock) Test
5020.1		Vibration (Sinusoidal Motion) Test
5021 Superseded	D 1008, D 895	Water Vapor Permeability of Containers or Packages
5022.1	*Tappi T 410	Basis Weight of Paper and Paperboard
5023		Incline-Impact Test
5024 Deleted	*Tappi T 400, T 412, T 484	Moisture Content of Paper and Paperboard
5025 Superseded	D 2016	Moisture Content of Wood
5026 Deleted		Penetration of Packaging Materials by Water
5027 Deleted		Penetration Test of Water Repellant Wood Preservative

\* Comparable test methods; not DOD adopted  
Supersedes page 30 of September 12, 1983

NUMERICAL INDEX OF TEST METHODS (Continued)

6000 Group-Chemical Analyses

101C Method No.	Superseding ASTM Method No.	Title
6001 Deleted		Absorption (Penetration) Test of Ink, Paint, etc.
6002 Deleted		Acidity, Alkalinity, and Hydrogen Ion Concentration (pH)
6003 Deleted		Unit Weight and Absorption Capacity of Desiccants
6004 Deleted		Absorption Capacity of Desiccant in Bags
6005		Ash and Loss on Ignition of Solid Materials
6006		Ash Content of Liquid Samples
6007 Deleted		Asphalt Content of Paper, Duplex, and Asphalt Impregnated
6009 Deleted		Boiling Nitric Acid
6010 Deleted		Qualitative Determination of Copper Content of Paper or Paperboard
6011.1 Deleted		Determination of Gaseous Oxygen in Hermetically Sealed Containers
6012 Deleted		Determining Effectiveness of Descaling Process Applied to Steel Drums
6013 Superseded	D 1030	Fiber Identification and Content
6014 Deleted		Moisture Content of Desiccant
6017 Deleted		Nonvolatile Content Test
6018 Deleted		Paraffin in Paper (Wax Content)
6019 Deleted		Silver-Tarnishing Test
6020 Superseded	D 549	Sizing (Rosin) in Paper and Paperboard
6021 Superseded	A 90	Test for Quantity of Zinc Coating
6022 Deleted		Test for Weight of Phosphate Coating
6023 Deleted		Volume of a Desiccant Unit

FED. TEST METHOD STD. NO. 101C  
MARCH 13, 1980  
CHANGE NOTICE 3  
14 OCTOBER 1988

THIS PAGE INTENTIONALLY LEFT BLANK

Supersedes unnumbered page of March 13, 1980

SECTION 5

INDEX OF TEST MATERIALS ACCORDING TO SPECIFIC  
MATERIALS OR TEST REQUIREMENTS  
ALPHABETICAL

Volume I - Tests for Packaging Materials

A. Corrugated, Paper & Paperboard

Title	101C Method No.	Superseding ASTM Method No.
Asphalt Content of Paper, Duplex and Asphalt Impregnated	6007 Deleted	
Basis Weight of Paper and Paperboard	5022.1	*Tappi T 410
Bursting Strength of Sheet Material	2007.1	
Flexural Properties of Corrugated Paperboard	2018 Superseded	D 1098
Flexural Properties of Veneer, Paper-Overlaid Veneer and Other Glued Constructions	2020 Superseded	D 3499, D 3500, D 3501, D 3502, D 3503
Flexural Properties of Wood-Base Fiber and Particle Panel Materials	2021 Superseded	D 1037
Fiber Identification and Content	6013 Superseded	D 1030
Folding Endurance Test	2023 Deleted	
Moisture Content of Paper and Paperboard	5024 Deleted	*Tappi T 400, T 412, T 484
Paraffin in Paper (Wax Content)	6018 Deleted	
Puncture Resistance	2031	
Puncture Resistance (Beach or G.E. Test)	2032 Superseded	*Tappi T 803

\* Comparable test methods; not DOD adopted  
Supersedes page 33 of September 12, 1983

SECTION 5 (Continued)

Volume I - Tests for Packaging Materials (Continued)

A. Corrugated, Paper & Paperboard (Continued)

Title	101C Method No.	Superseding ASTM Method No.
Qualitative Determination of Copper Content of Paper or Paperboard	6010 Deleted	
Short Column Test of Corrugated Fiberboard in the Cross-Machine Direction	2033 Superseded	*D 2808
Sizing (Rosin) in Paper and Paperboard	6020 Superseded	D 549
Submersion Test of Materials for Absorption of Liquid and Dimensional Stability	3025 Deleted	
Tearing Resistance (Elmendorf)	2036.1 Superseded	*Tappi T 414
Tensile Breaking Strength and Elongation of Paper and Paperboard	2038	
Water Run-Off Test of Paper	3029 Superseded	D 724

B. Cushioning Material

Title	101C Method No.	Superseding ASTM Method No.
Compressive Force-Displacement Characteristics of Cushioning Materials	2011 Deleted	
Creep Properties of Package Cushioning Materials Under Compression	2013.1 Superseded	D 2221
Load Deflection Characteristics of Resilient Cushioning Materials (Static Indentation Method)	2028 Deleted	

\* Comparable test method; not DOD adopted  
Supersedes page 34 of September 12, 1983

SECTION 5 (Continued)

Volume I - Tests for Packaging Materials (Continued)

A. Cushioning Material (Continued)

Title	101C Method No.	Superseding ASTM Method No.
Measurement of Length and Width of Specimens of Cushioning Materials	1002 Deleted	
Tensile Strength (Minimum) of Cushioning Materials for Packaging	2043 Deleted	
Thickness Measurements of Nonrigid Specimens	1003.2	
Thermal Conductivity of Cushioning Materials	4043 Superseded	C 177
Water Absorption by Cushioning Materials	4035 Deleted	

C. Plastics - Rigid, Sheet, Film Form

Title	101C Method No.	Superseding ASTM Method No.
Compressive Properties of Rigid Plastics	2012 Superseded	D 695
Coefficients of Friction of Film (Slip)	4005 Superseded	D 1894
Flammability of Flexible Barrier Material	3014.1 Superseded	D 568
Flexural Properties of Plastics	2019 Superseded	D 790
Flow Rate (Melt Index) of Thermoplastics Including Polyethylene, Polypropylene, Polystyrene, Nylon, etc.	2022 Superseded	D 1238
Plasticity and Recovery of Strippable Preservative Compound	2029 Deleted	

Supersedes page 35 of September 12, 1983

SECTION 5 (Continued)

Volume I - Tests for Packaging Materials (Continued)

A. Plastics - Rigid, Sheet, Film Form (Continued)

Title	101C Method No.	Superseding ASTM Method No.
Total Luminous Transmittance	4045 Superseded	D 1003
Tensile Properties of Plastics	2040 Superseded	D 638
Tensile Tear Test of Plastic Film and Thin Sheet	2046.1 Superseded	D 1004
Water Absorption Test of Plastics (Other Than Cushioning Materials)	4036 Superseded	D 570

D. General Materials

Title	101C Method No.	Superseding ASTM Method No.
Abrasion Test	4001 Superseded	*D 4157, *D 4158
Abrasive, Test for	4002 Deleted	
Absorption Capacity of Desiccant in Rags	6004 Deleted	
Adhesion of Barrier Material	2001 Deleted	
Adhesive Shear Test of Glued Lap Joints in Packaging Materials	2002 Deleted	
Bending Tests of Packaging Materials	2003 Deleted	
Blocking Resistance of Packaging Materials	3003	
Bridging Qualities of Cocooning Materials	2004 Deleted	

Supersedes page 36 of September 12, 1983

SECTION 5 (Continued)

Volume I - Tests for Packaging Materials (Continued)

B. General Materials (Continued)

Title	101C Method No.	Superseding ASTM Method No.
Brittleness of Nonstrippable Coatings (Knife Test)	2005 Deleted	
Brittleness of Strippable Coating Compounds	2006 Deleted	
Compressibility and Recovery Test for Gasket Material	2008 Superseded	F 36
Compression Set After Constant Deformation	2009 Deleted	
Compression Set After Cycling	2010 Deleted	
Cleanliness	4004	
Curling and Twisting Tendencies of Barrier Material	2015.1	
Delamination Resistance of Heat-Seal	3015.2 Changed	
Density and Specific Gravity	4008 Deleted	
Dielectric Constant and Dissipation Factor	4009 Superseded	D 1531
Drying Time Test	4010 Deleted	
Dustiness	4011 Deleted	
Effect of a Preservative Compound on the Color-Indicating Property of Cobalt Chloride Impregnated Desiccant	3009 Deleted	
Electrostatic Properties of Materials	4046.1	
Flash and Fire Point Tests (Flammability)	4012 Superseded	D 1310
Flexing Procedure for Barrier Materials	2017.1 Changed	



SECTION 5 (Continued)

Volume I - Tests for Packaging Materials (Continued)

D. General Materials (Continued)

Title	101C Method No.	Superseding ASTM Method No.
Foaming and Separation Properties of Metal Conditioners	4013 Deleted	
Hardness	4014 Deleted	
Heat Sealed Seam Test	2024	
Impact Puncture Resistance of Films and Barriers	2025 Deleted	
Marking Characteristics of Ink	4016 Deleted	
Melting Point of Wax	4017 Superseded	*D 87
Moisture Content of Desiccant	6014 Deleted	
Nonvolatile Content Test	6017 Deleted	
Odor Test	4018 Superseded	E 462, E 619
Opacity (Photometer or Densitometer Method)	4019 Deleted	
Opacity	4020 Deleted	
Plywood Glue Shear Test	2030 Superseded	D 3499, D 3500, D 3501, D 3502, D 3503
Pliability of Barrier Materials	2071 Deleted	
Polarscopic Examination for Annealing of Glass	4023 Superseded	C 148

\* Comparable test methods; not DOD adopted  
Supersedes page 38 of September 12, 1983

SECTION 5 (Continued)

Volume I - Tests for Packaging Materials (Continued)

D. General Materials (Continued)

Title	101C Method No.	Superseding ASTM Method No.
Puncture Resistance and Elongation Test (1/8 Inch Radius Probe Method)	2065.1	
Silver Tarnishing Test	6019 Deleted	
Size of Desiccant Particles	4030 Deleted	
Sprayability and Delivery Rate	4039 Deleted	
Springback (Fold Retention)	2034 Deleted	
Stiffness (Bending Resistance of Wrapping Material)	2035.1 Deleted	
Strength of Desiccant Particles	4040 Deleted	
Strippability of Coating Materials	4041 Deleted	
Tensile Breaking Strength and Elongation of Cloth, and Similar Sheet Materials	2037 Deleted**	
Tensile Breaking Strength and Elongation of Thread, Twine and Small Cords	2039 Deleted	
Tensile Strength of Strapping (With or Without Joints)	2044 Superseded	D 3953
Tensile Strength, Yield Point, and Elongation of Sheet Steel for Containers	2045 Deleted	
Test for Quantity of Zinc Coating	6021 Superseded	A 90
Test for Weight of Phosphate Coating	6022 Deleted	

\*\* Use FED-STD-191 Methods 5100 or 5102, as applicable  
Supersedes page 39 of September 12, 1983

SECTION 5 (Continued)

Volume I - Tests for Packaging Materials (Continued)

D. General Materials (Continued)

Title	101C Method No.	Superseding ASTM Method No.
Torsion Test for Threads of Protective Caps and Plugs	2047 Deleted	
Unit Weight and Absorption Capacity of Desiccants	6003 Deleted	
Vibratory Flexing Properties of Barrier Materials	2049 Deleted	
Viscosity Test	4032 Superseded	D 1545, D 562
Volume of a Desiccant Unit	6023 Deleted	
Water Vapor Permeability Test of Packaging Materials (Water Vapor Transmission Rate Test)	3030.1	

E. Tapes

Title	101C Method No.	Superseding ASTM Method No.
Accelerated Aging of Pressure-Sensitive Packaging Tapes (Heat and Humidity or Heat Only)	4047 Superseded	D 3611
Adhesion of Pressure-Sensitive Tapes	2050 Superseded	D 3330
Adhesion of Pressure-Sensitive Tapes to Paper at Low Temperature	2051 Superseded	D 3889
Adhesiveness of Gummed Paper Tapes to Paper	2052 Deleted	
Curling and Twisting on Unwind of Pressure-Sensitive Tapes	2053 Superseded	D 3813

Supersedes page 40 of September 12, 1983

SECTION 5 (Continued)

Volume I - Tests for Packaging Materials (Continued)

E. Tapes (Continued)

Title	101C Method No.	Superseding ASTM Method No.
Holding Power of Pressure-Sensitive Tapes	2054 Superseded	D 3654
Holding Power Test for Filament (Lineally and Multi-Directional) Tapes	2055 Superseded	D 3654
Impact Resistance Test for Filament (Lineally and Multi-Directional) Reinforced Tapes	2056 Deleted	
Resistance to Creep of Pressure-Sensitive Plastic-Backed Tapes	2057 Deleted	
Shrinkage of Tapes With Plastic Backing	4048 Deleted	
Strength of Tape Backing Diaphragm Bursting Method	2058 Superseded	D 3662
Tearing Resistance (Internal) of Tapes	2059 Deleted	
Tearing Resistance of Tapes With Plastic Backing	2060 Deleted	
Tensile Strength (Breaking Strength) and Elongation of Filament (Lineally and Multi-Directional) Reinforced Pressure-Sensitive Tapes	2061 Superseded	D 3759
Tensile Strength (Breaking Strength) and Elongation of Pressure-Sensitive Tapes [(Other than Filament (Lineally and Multi-Directional) Reinforced)]	2062 Superseded	D 3759
Tensile Strength (Breaking Strength), Elongation, and Stretch Force of Pressure-Sensitive Tapes	2063 Superseded	D 3759
Thickness of Tapes	1004 Superseded	D 3652
Unwind of Pressure-Sensitive Tapes	2064 Superseded	D 3811

Supersedes page 41 of October 8, 1982

SECTION 5 (Continued)

Volume I - Tests for Packaging Materials (Continued)

E. Tapes (Continued)

Title	101C Method No.	Superseding ASTM Method No.
Water-Penetration Rate of Pressure Sensitive Tapes	3032 Superseded	D 3816
Water Solubility of Pressure-Sensitive Tapes	4049 Deleted	
Water-Vapor Transmission Rate of Pressure-Sensitive Tapes	3033 Superseded	D 3833
Weatherometer Aging of Pressure-Sensitive Tapes	4050 Superseded	D 3815

VOLUME II - Conditioning, Accelerated Weather and Environmental Resistance Tests

Title	101C Method No.	Superseding ASTM Method No.
Absorption of Water Vapor and Dimensional Changed in Packaging Material	3001 Deleted	
Bleed-Through or Smearing	3002 Deleted	
Cleanliness Degradation of Critically Clean Products in Packages	5002 Deleted	
Color Test for Humidity Indicators	4006 Deleted	
Compatibility Tests of Materials	3004 Deleted	
Contact Corrosivity Test of Solid Materials in Flexible, Rigid or Granular Forms	3005	
Conditioning (Environments and Exposures)	4007.1 Deleted	
Corrosion Inhibiting Ability of V.C.I. Vapors	4031	

Supersedes page 42 of September 12, 1983

SECTION 5 (Continued)

Volume II - Conditioning, Accelerated Weather and  
Environmental Resistance Tests (Continued)

Title	101C Method No.	Superseding ASTM Method No.
Corrosion Resistance Test of Coatings	3006 Deleted	
Corrosion Tests of Container Components	3007 Deleted	
Determination of Gaseous Oxygen in Hermetically Sealed Containers	6011.1 Deleted	
Effect of Protective Coatings on Painted Surfaces	3010 Deleted	
Etching Properties of Metal Containers	3011 Deleted	
Exudation of Strippable Protective Compounds	3013 Deleted	
Humidity Control by Desiccant	4015 Deleted	
Leaks in Containers	5009.3 Changed	
Moisture Content of Wood	5025 Superseded	D 2016
Oil Resistance of Heat Sealable Films and Barriers	3015.2	
Oil Resistance of Pressure-Sensitive Tapes	3016 Deleted	
Oil Transmission Test for Packaging Materials	3017 Deleted	
Penetration of Packaging Materials by Water	5026 Deleted	
Penetration Test for Water Repellent Wood Preservative	5027 Deleted	
Performance of a Package Window Assembly in Flexible Barrier Material	3018 Deleted	

SECTION 5 (Continued)

Volume II - Conditioning, Accelerated Weather and  
Environmental Resistance Tests (Continued)

Title	101C Method No.	Superseding ASTM Method No.
Puncture Resistance and Elongation Test (1/8 Inch Radius Probe Method)	2065.1	
Rate of Penetration of Packaging Materials by Water	3019.1 Deleted	
Resistance of Packaging Materials to Fungi	3020 Deleted	
Examination for Compatibility of Containers for Liquids With Their Contents	3021 Deleted	
Resistance of Sheet Materials to Penetra- tion by Water	3022 Superseded	D 779
Resistance of the Coating of Steel Ship- ping Pails to Liquids	3023 Deleted	
Salt Spray Test	4026 Superseded	B 117
Thermal Shock Test	4044 Deleted	
Water Resistance of Markings	3027	
Water Resistance of Packaging Materials (Ply Separation)	3028	
Water Vapor Permeability of Containers or Packages	5021 Superseded	D 1008, D 895
Workability of Coating Materials After Application	3031 Deleted	

SECTION 5 (Continued)

Volume III - Package and Product Performance

Title	101C Method No.	Superseding ASTM Method No.
Assembly and Disassembly Test of Containers or Complete Packs	5001 Deleted	
Compression Test for Shipping Containers	5003 Superseded	D 642
Cornerwise Drop (Rotational) Test	5005.1	
Dent Resistance	5006 Deleted	
Drop Test (Free Fall)	5007.1	
Edgewise Drop (Rotational Test)	5008.1	
Incline-Impact Test	5023	
Fit of Covers on Telescope-Style Containers	1001 Deleted	
Lateral Resistance Test for Fasteners	2027 Deleted	
Leakage of Gaskets for Floating Bag Barriers	4024 Deleted	
Mechanical Handling Test	5011.1	
Pendulum Impact Test	5012	
Revolving Hexagonal Drum Test	5013 Superseded	*D 782
Rollover Test	5014	
Shipping Test	5015 Deleted	
Superimposed-Load Test (Stackability, With Dunnage)	5016.1	
Superimposed-Load Test (Uniformly Distributed, Without Dunnage)	5017	

\* Comparable test method; not DOD adopted  
Supersedes page 45 of September 12, 1983



FED. TEST METHOD STD. NO. 101C  
MARCH 13, 1980  
CHANGE NOTICE 3  
14 OCTOBER 1988

SECTION 5 (Continued)

Volume III - Package and Product Performance (Continued)

Title	101C Method No.	Superseding ASTM Method No.
Tipover Test	5018	
Vibration (Repetitive Shock) Test	5019.1	
Vibration (Sinusoidal Motion) Test	5020.1	

Supersedes page 46 of October 8, 1982

## SECTION 6

### NOTES

#### 1. DETAILED SPECIFICATIONS

Specifications should give the method number, and procedure letter and option, if any, of the test method to be used to determine a particular property. When necessary, special requirements, such as conditioning procedures or testing conditions different than those specified in the method, also should be given in the specification or in accompanying procurement documents.

#### 2. SOURCES OF FEDERAL STANDARDIZATION DOCUMENTS

(Those outside the Federal Government may obtain copies of Federal specifications and standards as stated in the Index of Federal Specifications, Standards and Commercial Item Descriptions. The Index, including cumulative supplements issued during the year, is sold on subscription by the Superintendent of Documents, U.S. Government Printing Office, Washington, DC 20402.

(Single copies of Federal specifications and standards required for bidding purposes are available from the General Services Administration Business Service Centers in Boston, MA; New York, NY; Atlanta, GA; Chicago, IL; Kansas City, MO; Fort Worth, TX; Denver, CO; San Francisco, CA; Los Angeles, CA; and Seattle, WA, or from the General Services Administration Supply Distribution Facility Franconia - Building A, Loisdale Road, Franconia, VA 22105.

(Federal Government activities may obtain copies of Federal Specifications and Standards from established distribution points in their agencies.)

#### 3. SOURCES OF AMERICAN SOCIETY FOR TESTING AND MATERIALS STANDARDS

(Federal Government activities may obtain copies of accepted American Society for Testing and Materials Standards from the Naval Publications and Forms Center, Philadelphia, PA 19120. Activities outside the Federal Government are to obtain copies directly from the American Society for Testing and Materials, 1916 Race Street, Philadelphia, PA 19103.)

#### 4. SOURCES OF INFORMATION

The methods in this standard are based upon methods, information, comments, suggestions, and laboratory data from many sources including Government, industrial and private laboratories; the American Society for Testing and Materials; the Aerospace Industries Association; the

National Security Industrial Association; the Technical Association of the Pulp and Paper Industry; the National Flexible Packaging Association; Pressure-Sensitive Tape Council; and various other technical committees and private individuals. The consolidation of all available information has been essentially determined by a Department of Defense Task Committee for Development of Packaging Test Methods.

5. METRIC EQUIVALENTS

When laboratory apparatus is calibrated in accordance with the metric system, metric units may be substituted in those methods which specify only English units. Conversion to metric equivalents should be made in accordance with the ASTM E380-76 Standard for Metric Practice published by the American Society for Testing and Materials, 1916 Race Street, Philadelphia, Pa. 19103.

6. REFEREE TESTS

6.1 Conditioning. In any of the procedures in this standard, where results are dependent upon moisture conditions of specimens, the following conditions will apply:

$73^{\circ} \pm 2^{\circ}\text{F.}$   
 $50 \pm 2$  percent relative humidity.

Military Interest:

Civil Agency Coordinating Activity:  
GSA

Custodians:

Army - SM  
Navy - AS  
Air Force - 69

Preparing Activity:  
Navy - AS  
DOD Project PACK-0693

Review Activities:

Army - GL, MI, AR, ME, MR, EA  
Navy - OS, SH, SA, YD  
Air Force - 99

User Activities:

Army - AL, CR, AV  
Navy - EC, MC, CG

Supersedes unnumbered page of March 13, 1980

THICKNESS MEASUREMENTS OF NONRIGID SPECIMENS

PROCEDURE A

1. SCOPE

1.1 This procedure is intended for measuring specimen thickness with a dial micrometer to the nearest 0.001 inch.

1.2 This procedure is appropriate for products in film, sheet, pad or block form such as felt, fiberboard (corrugated or solid), bound fiber, fiberglass, synthetic fibers, plywood, cushioning materials, etc.

1.3 For measuring tape thickness use FED STD TEST METHOD 101/1004.

2. DEFINITIONS

2.1 Not applicable.

3. APPARATUS

3.1 A dial micrometer reading in 0.001 inch and calibrated to be accurate within one-half of 1 percent or one dial division, whichever is the greater tolerance.

3.2 Weights preferably in the form of flat plates to exert the specified bearing pressure when placed on the specimen. The weights (flat plates) shall be slightly larger than the test specimen in order to provide equal compression to the whole measuring surface of the specimen.

4. SPECIMENS

4.1 The specimens will be those used for other tests unless otherwise specified.

5. CONDITIONING

5.1 Unless otherwise specified, the specimens will be conditioned as required for the tests for which the specimens are intended.

6. PROCEDURE

6.1 Unless the use of only one or the other is specified (see 8.1.2), thickness measurements may be made using either a hand micrometer (6.1.1) or a dial micrometer on a stand (6.1.2).

6.1.1 When the hand micrometer composed of an anvil and micrometer mounted on a frame is used, first zero the dial, then place the specimen between the dial stem and the anvil, and read the dial to the nearest

0.001 inch. An appropriate anvil and dial stem attachment to provide the specified bearing area and pressure must be used throughout this procedure (see 6.1.3).

6.1.2 When the dial micrometer on a stand is used, first zero the dial against the appropriate plate (3.2), while it rests on the flat base of the stand. Then raise the plate, being careful not to disturb the zero setting; place the specimen centered beneath the dial and between the plate and the base; and gently lower the plate so it rests centered upon the specimen (see fig. 1). After the specified time interval under the weight of the plate, read and record the center thickness measurement to the nearest 0.001 inch (see 6.1.3).

6.1.3 If the range of the dial in either 6.1.1 or 6.1.2 is less than the specimen thickness, the zero setting shall be made with a standard gage block of appropriate thickness in place of the specimen, and the thickness of the gage block shall be added to each dial reading when measuring the thickness of specimens.

## 7. REPORT

7.1 Immediately following each test the report (official record) of the facts pertinent to the test shall be completed, and shall include the following:

7.1.1 A statement that the test was conducted in compliance with this procedure, or a description of the deviations from this procedure. Report all options selected and details of otherwise specified procedure that were followed as permitted in 3.2 and 6.1.

7.1.2 Identification of the specimen and the specific material tested.

7.1.3 Results of the test. Report the thickness to the nearest 0.001 inch and identify each point on the specimen where it was measured.

7.1.4 When the test is performed to check compliance with requirements, state that the specimen did or did not meet the requirements and give the source for the requirements.

7.1.5 When the test is conducted to evaluate or compare products or methods, the report shall include a statement of any observations that may lead to improvements.

## 8. NOTES

8.1 When specifying this method, the following additional information shall be supplied:

8.1.1 Mandatory information:

- a. Minimum diameters or areas of anvil and presser foot.
- b. Load (ounces, pounds, or grams) or pressure (p.s.i) to be exerted on the specimen (including the weight of 3.2 if used, and the spring pressure or dial stem weight load exerted by the instrument at the particular thickness).
- c. Length of time the pressure shall be exerted on the specimen before taking the reading.
- d. Description of specimen, with minimum distance from an edge at which measurements may be taken.

8.1.2 Optional information:

- a. The particular type of micrometer to be used (see 6.1) if required.
- b. Special conditioning (see 5.1), if required.

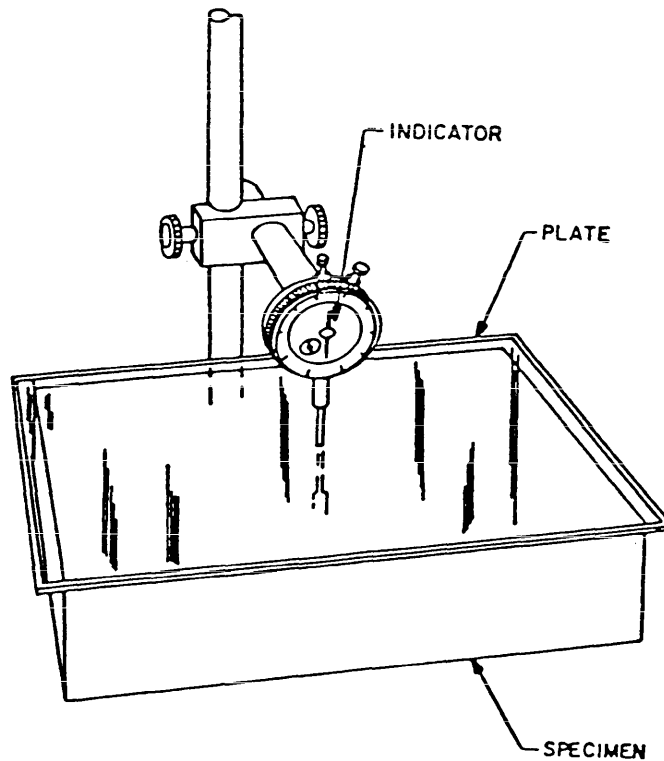

Figure 1. Thickness measurement apparatus.

METHOD 1003.2  
October 8, 1982  
CHANGE NOTICE 1

PROCEDURE B

TAPPI T 411 - THICKNESS (CALIPERS) OF PAPER AND PAPERBOARD

1. SCOPE

1.1 When specified in the commodity specification, contract or order, Procedure B may be used in lieu of Procedure A for paperboard products.

## BURSTING STRENGTH OF SHEET MATERIALS

### 1. SCOPE

1.1 This method covers two procedures for measuring the hydrostatic pressure in pounds per square inch required to produce rupture of a sheet material when increasing pressure is applied at a controlled rate through a rubber diaphragm to a circular area 1.2 inches in diameter of flat sheet rigidly held on the periphery of the test area. Method is not appropriate for materials that are more elastic than the rubber diaphragm.

1.2 Procedure A is the TAPPI standard T-403, which except as noted below may be used for paper and other sheet materials when the thickness does not exceed 0.025 inch and bursting strength values are less than 250 p.s.i. This procedure incorporates the essential requirements of the similar test appearing in ASTM D-774-67. Components of corrugated and solid fiberboard shall be tested in accordance with Procedure B.

1.3 When the thickness of the material for the test exceeds 0.025 inch or the range in bursting strength values is expected to exceed 250 p.s.i., procedure B which follows is applicable. Also, procedure B should be used to compare materials whenever values may include strengths greater than 250 p.s.i.

### 2. DEFINITIONS

2.1 Not applicable.

### 3. APPARATUS

3.1 The apparatus shall have:

3.1.1 Means for clamping the test specimen without slippage between two annular, plane unpolished surfaces which may have fine, concentric tool marks not over 0.002 inch deep. The upper clamping surface shall have an outside diameter of  $3.83 \pm 0.02$  inches and an inside diameter of  $1.245 \pm 0.005$  inches with all edges relieved of sharpness (0.025-inch radius). The lower clamping surface shall be formed of a plate  $0.225 \pm 0.015$  inch thick and shall have an outside diameter of  $3.88 \pm 0.02$  inches and an inside diameter of  $1.25 \pm 0.01$  inches, and the lower edge of the opening shall be rounded off to a radius of 0.125 inch to prevent it from cutting the rubber diaphragm when pressure is applied. The lower surface of the plate shall have a raised circular rib of semicircular cross section (0.06 inch in height, 0.12 inch in width, and 2.75 inches in diameter) to facilitate holding the rubber diaphragm in place. The upper clamping ring shall be connected to the clamping mechanism through



a swivel joint to insure even clamping pressure. During tests, the circular edges of the openings in the two clamping plates shall be substantially concentric, with no overlapping at any point. The clamping faces shall be flat and parallel. The apparatus shall be equipped with a device to indicate the clamping pressure in pounds per square inch applied to the specimen. One satisfactory device is illustrated in figure 1.

3.1.2 A rubber diaphragm clamped between the lower clamping plate and the rest of the apparatus, so that, before the diaphragm is stretched by pressure underneath it, the center of the upper surface is even with the plane of the clamping surface. A pressure of 40 to 45 p.s.i. should be capable of distending the diaphragm to a height of 1.8 centimeters above the clamping plate.

3.1.3 Means for applying controlled increasing hydraulic pressure to the underside of the diaphragm until the specimen bursts. This pressure shall be generated by a motor-driven piston forcing a liquid (glycerin) into the pressure chamber of the apparatus at a rate of  $170 \pm 15$  milliliters per minute.

3.1.4 A maximum-reading pressure gage, graduated to indicate bursting pressure in pounds per square inch with an accuracy of 0.25 percent of full scale or 1 percent of a given scale reading, whichever is the greater tolerance.

#### 4. SPECIMENS

4.1 Each test specimen shall be an area of the material at least 6 by 6 inches, and shall be representative of the sample. Not less than 10 specimens shall be tested to establish the bursting strength.

#### 5. CONDITIONING

5.1 The surfaces of each specimen shall have free access to the conditioning atmosphere. Unless otherwise specified, the specimens shall first be dried at room temperature with relative humidity not greater than 35 percent, and then conditioned in an atmosphere uniformly maintained at  $73^{\circ} \pm 3.5^{\circ}\text{F}$  and  $50 \pm 5$  percent relative humidity, for a period not less than required for the specimen to attain a temperature and a moisture content in equilibrium with the conditioning environment. A period of 24 hours shall be considered adequate for this purpose.

#### 6. PROCEDURE

6.1 The tests shall be made in the conditioning atmosphere  $73^{\circ} \pm 3.5^{\circ}\text{F}$  and  $50 \pm 5$  percent relative humidity.

6.2 Specimens shall be clamped at a clamping pressure sufficient to prevent slippage of the specimen. Record the clamping pressure applied. (Recommended clamping pressure for corrugated fiberboard is 20 p.s.i., but should approach the flat crush strength of the fiberboard.)

6.3 Apply the hydrostatic pressure until rupture occurs and record the maximum registered by the pressure gage.

6.4 Make an equal number of tests but not less than five on each side of the material.

## 7. REPORT

7.1 Immediately following each test the report (official record) of the facts pertinent to the test shall be completed, and shall include the following:

7.1.1 A statement that the test was conducted in compliance with this procedure, or a description of the deviations from this procedure. Report all options selected and details of otherwise specified procedure that were followed as permitted in selection of Procedure A or B, and in 3.1.4 (indicate gage range), 4.1, and 5.1.

7.1.2 Identification of each specimen and the specific material tested.

7.1.3 Results of the test. Report the bursting strength of each specimen and the average for each direction through the material to the nearest p.s.i.

7.1.4 When the test is performed to check compliance with requirements, state that the specimen did or did not meet the requirements and give the source for the requirements.

7.1.5 When the test is conducted to evaluate or compare products or methods, the report shall include a statement of any observations that may lead to improvements.

## 8. NOTES

8.1 Details are given with the qualification, "unless otherwise specified," in the paragraphs regarding: Specimens (4.1), Conditioning (5.1).

8.2 The standard test procedure A incorporates the essential requirements of the similar test appearing in ASTM D 774-67 and in UU-P-31b as method 112. For many materials method 112 of UU-P-31b has been specified without regard to the limitations on thickness of material (0.025 inch) and strength (250 p.s.i.). Consequently, for thick

METHOD 2007.1  
March 13, 1980

or strong materials, method 112 of UU-P-31b may not actually be used when specified. Procedure B is included to provide for thicker or stronger materials.

Bursting strengths measured using the same procedure are comparable, but strengths measured by Procedure A are not comparable with those measured by Procedure B. Discard values obtained from bursts showing liner creases when computing the average. Also, disregard audible double bursts.

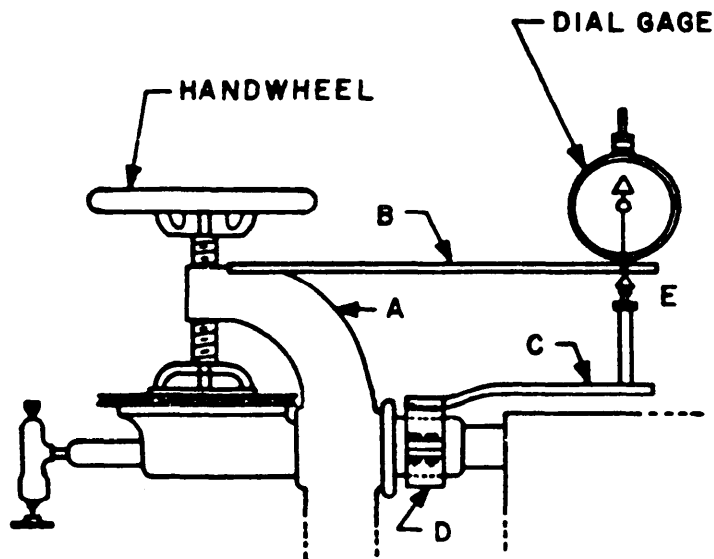

Key:

- A-Yoke of tester.
- B-Gage support rigidly secured to yoke near top.
- C-Arm welded to split ring.
- D-Split ring rigidly attached to housing.
- E-Contact surface.

Note: Calibrate dial gage in relation to clamping pressure applied to the specimen in pounds per square inch.

Figure 1. A device to indicate clamping pressure applied to bursting strength test specimen.

CURLING AND TWISTING TENDENCIES OF BARRIER MATERIALS

1. SCOPE

1.1 This test is used to determine the curling and twisting tendencies of barrier materials when exposed to normal or elevated temperature and relative humidity. (For tapes use FED STD TEST METHOD 101/2053).

2. DEFINITIONS. In a vertically suspended specimen:

2.1 Curl is defined as rotation (roll) about a horizontal axis that is parallel to the plane of the clamped edge of the specimen.

2.2 Twist is defined as rotation about an axis through the midpoints of the top and bottom edges of the specimens.

3. APPARATUS. The following equipment is required:

3.1 A horizontal platform and a suitable support bar from which to suspend specimens are required. A suitable means of clamping one end of specimens and allowing them to hang is required. A baseline shall be drawn on the platform, which is the vertical projection of the support bar centerline.

3.2 A chamber or room maintained at  $73 \pm 3.5^{\circ}\text{F}$  and  $50 \pm 5$  percent relative humidity in which to condition specimens and perform tests.

3.3 A drying oven maintained at a temperature of  $160 \pm 2^{\circ}\text{F}$ .

4. SPECIMENS

4.1 Specimens shall be selected at random and in sufficient number to represent adequately the variation of the material.

4.2 Each specimen shall be  $12 \pm 1/16$  inch by  $36 \pm 1/16$  inch. When hygroscopic material is being tested, measure and cut the specimens after conditioning (see 5.1). When the material being tested is orthotropic include in the tests, specimens cut with their length parallel to each principal direction.

5. CONDITIONING

5.1 Unless otherwise specified, condition the barrier materials from which specimens will be obtained to equilibrium in an atmosphere uniformly maintained at  $73 \pm 3.5^{\circ}\text{F}$  and  $50 \pm 5$  percent relative humidity.

6. PROCEDURE

6.1 Perform tests in an atmosphere maintained at  $73 \pm 3.5^{\circ}\text{F}$  and  $50 \pm 5$  percent relative humidity.

6.2 Clamp the 12-inch end of the specimen at a minimum of two points, and suspend the specimen so that clamped end is parallel to and  $36 \pm 1/16$  inch above the horizontal platform. Allow curling or twisting to proceed until the specimen is stable. Measure to the nearest  $1/16$  inch the vertical distance from the upper 12-inch end to the lowest portion of the specimen (see figure 1, dimension B). Estimate the extent of twist in degrees by observing the angle between the baseline (3.1) and the vertical (downward) projection, onto the horizontal platform, of the lower edge (end) of the specimen.

6.3 Transfer specimens (from 6.2) while still hanging from the support, to a forced draft oven maintained at a temperature of  $160 \pm 2^{\circ}\text{F}$ . Arrange the specimens in the oven to permit free circulation of air. Allow to remain for 168 hours. Remove the specimens from the oven and allow them to cool in the conditioning (5.1) atmosphere for 2 hours while still suspended from the support. Measure amount of curling and estimate extend of twist as described in 6.2.

6.4 Calculate percentage of curling as follows:

$$\text{curling percentage} = \frac{A-B}{A} \times 100$$

where:

A = actual length (in 36-inch direction) in inches of the specimen in the "flat" state

B = vertical distance, in inches, from the upper edge of the barrier material to the lowest portion of the suspended specimen.

7. REPORT

7.1 Immediately following the test, report (official record) the facts pertinent to the test including the following:

7.1.1 State that the test was conducted in compliance with this procedure or describe any deviations from this procedure. Report details of otherwise specified procedures that were followed as permitted in 5.1.

7.1.2 Identify the specimens and the specific material tested.

7.1.3 State the principal direction of the material with respect to the length of the specimen. State the percent curling as calculated in 6.4 and the approximate number of degrees of twisting (6.2) both when tested after conditioning and after exposure to high temperature aging described in 6.3.

7.1.4 When the test is performed to check compliance with requirements, state that the specimens did or did not meet the requirements, and give the source for the requirements.

7.1.5 When the test is conducted to evaluate or compare products or methods, include a statement of any observations that may lead to improvements.

8. NOTES. Not applicable.

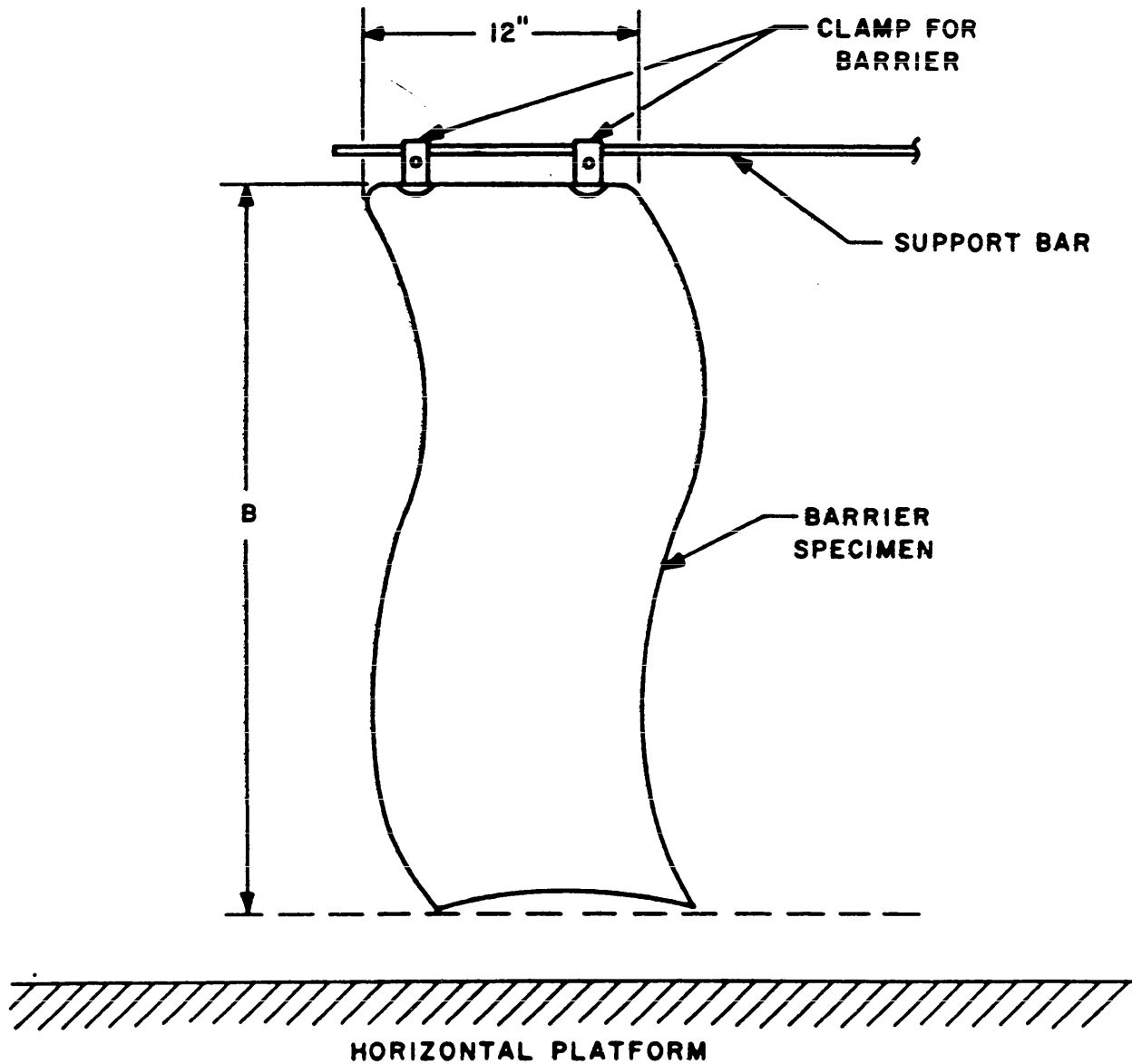

Figure 1. Apparatus and specimen for determining curling and twisting tendencies of barrier materials.

## FLEXING PROCEDURE FOR BARRIER MATERIALS

### 1. SCOPE

1.1 This procedure evaluates the effect of flexing or accelerated aging and flexing on barrier materials by determining the water vapor transmission rate after repeated flexing.

### 2. DEFINITIONS

2.1 Barrier. Any material limiting passage through itself of solids, liquids, semi-solids, gases, or forms of energy such as ultra-violet light.

2.2 Flexible. Easily hand-folded, flexed, twisted, and bent.

2.3 Seal. A continuous joint of two or more surfaces of sheet material such as made by fusion or adhesion.

### 3. APPARATUS

3.1 The Gelbo Flex-Tester or equivalent. The apparatus shall consist essentially of a 3-1/2-inch diameter stationary head and a 3-1/2-inch diameter movable head spaced at a distance of 7 inches from face-to-face at the starting position of the stroke. The specimen supporting shoulders on the heads are 1/2 inch wide. The motion of the movable head is controlled by a grooved shaft to which it is attached. For the full stroke operation, for use in testing some materials as specified, the groove is so designed as to give a twisting motion of 440° in the first 3-1/2 inches of the stroke of the movable head followed by a straight horizontal motion of 2-1/2 inches. The motions of the movable head are uniform except for that portion where the rotary motion is changing to straight translational motion. The motion of the machine is reciprocal, a full cycle consisting of the forward and return strokes. For the alternate short stroke operation, for use in testing other materials as specified, the movable head travels only 3-1/4 inches in each direction in such a manner that a twisting motion of only 400° is imparted to the material. The flexing for all materials shall be 40 cycles per minute. In the event an equivalent test is used, proof of the equivalence with the performance of the Gelbo Flex-Tester must be presented to the qualifying agency for their approval of the substitute equipment.

### 4. SPECIMENS

4.1 Not less than four 12- by 8-inch specimens shall be cut from the barrier material, two in each principal direction (machine and cross) unless otherwise specified. Unless otherwise specified, four additional 13- by 9-inch specimens shall be cut out, two in each principal direction, and shall



be aged by exposing the specimens in an atmosphere of 80 to 85 percent relative humidity at  $160^{\circ} \pm 2^{\circ}\text{F}$  for 72 consecutive hours. This relative humidity can be maintained at  $160^{\circ}\text{F}$  over a saturated solution of ammonium sulfate (85 grams per 100 ml water) in a closed vessel. At the completion of the aging exposure, the test specimens shall be returned to room conditions for 4 hours and then trimmed to produce four aged specimens each 12 by 8 inches. Each test specimen, unaged and aged, shall be prepared for flexing by heat sealing, or joining by more appropriate means, the two shorter edges of the sheet with 1/2-inch fintype seam, thus producing an approximate 3-1/2-inch diameter cylinder or sleeve 8 inches long.

## 5. CONDITIONING

5.1 The surfaces of each specimen shall have free access to the conditioning atmosphere. Unless otherwise specified, condition the specimens to equilibrium in an atmosphere uniformly maintained at  $73^{\circ} \pm 3.5^{\circ}\text{F}$  and  $50 \pm 5$  percent relative humidity, for a period not less than required for the specimen to attain a temperature and a moisture content in equilibrium with the conditioning environment. A period of 24 hours shall be considered adequate for this purpose.

## 6. PROCEDURE

6.1 Flexing procedure shall be performed in the conditioning atmosphere. The sleeve, in cylindrical form, shall be positioned on the circular heads of the flexing apparatus and secured tightly by adjusting clamps. The drive shaft of the Flex machine shall be at dead center (i.e., perfectly horizontal), before flexing is initiated. Each sample shall be flexed for 20 cycles using the motion specified in the reference to this procedure (see 8.1).

6.2 The water vapor transmission rate shall then be determined by forming the specimen into a pouch and testing according to Method 3030, procedure A(1).

## 7. REPORT

7.1 The report prepared according to Method 3030 shall include under 7.1.2 reference to this procedure and include a statement of any deviations from this procedure.

## 8. NOTES

8.1 For MIL-B-131, Class 1 materials, a flexing motion using the full stroke (6 inches) and  $440^{\circ}$  rotation in the first 3-1/2 inches of the stroke is specified, and for Class 2 materials only 3-1/4-inch stroke with a twisting motion of only  $400^{\circ}$  is specified. For other materials, the applicable alternative should be stated in the reference to this procedure.

8.2 Details of this flexing procedure are given with the qualification, "unless otherwise specified," in the paragraphs regarding:

Apparatus (3.1)  
Specimens and aging (4.1)  
Conditioning (5.1)  
Flexing procedure (6.1)



## HEAT-SEALED SEAM TEST

### 1. SCOPE

1.1 This procedure determines whether or not the strength of a heat-sealed seam is adequate to resist a dead weight load applied in a manner tending to open the seam. The test does not measure the tensile strength of the seam or indicate its efficiency in developing the strength of the material joined.

### 2. DEFINITIONS

2.1 Not applicable.

### 3. APPARATUS

3.1 Appropriate heat-sealing equipment with accurate controls of temperature, pressure, and time adjusted to fuse the material joined in the heat-sealed seam. The quality of seams should be reproducible.

3.2 A test frame with means to hold not more than 2 inches of the upper end of the specimen so that the rest of the specimen hangs free.

3.3 A weighted clamp 1 inch wide to suspend from the lower portion of the specimen. Unless otherwise specified, the total weight shall be 3-1/2 pounds (see notes).

### 4. SPECIMENS

4.1 Sheet materials. Unless otherwise specified, a representative 6- by 12-inch piece of the material shall be used to form the test specimens. Fold the piece in the middle and seal the 6-inch ends together on the heat-sealing equipment adjusted appropriately for the material. The edge of the heat-sealed area should be accurately marked while in the sealer. From the flattened tube so formed, cut perpendicularly to the seam to form three bands 1 inch wide but do not use the end strips. Cut each band on the fold line to form a 1-inch wide specimen with the heat-sealed seam extending across the specimen at midlength. The heat-sealed seams shall be permitted to cool at room temperature for 1 hour before cutting the test specimens.

4.2 Fabricated bags, pouches, etc. Unless otherwise specified, a representative fabricated item or items shall be used to form test specimens of each heat-sealed seam. Flatten the item with the test seam at one edge, and cut 1-inch wide strips perpendicular to the seam to form double thick strips 1 inch wide by a convenient length so that

**METHOD 2024**  
**March 13, 1980**

when the strip is extended the seam is crosswise in the specimen at midlength. Not less than three specimens from each typical heat-sealed seam shall be tested. The closure seam, or any others freshly formed, shall be permitted to cool at room temperature for 1 hour before cutting the test specimens.

**5.           CONDITIONING**

**5.1**           Unless otherwise specified, no special conditioning of the specimen is required.

**6.           PROCEDURE**

**6.1**           Unless otherwise specified, the test shall be performed at normal room conditions.

**6.2**           Fasten one end of the test specimen to the test frame and allow the rest of the specimen to hang free. Carefully and without impact loading, attach the weighted clamp to the lower end of the specimen so the weight is suspended by the specimen.

**6.3**           Unless otherwise specified, the weight shall remain freely suspended for 5 minutes. Then remove the weight and measure to 1/32 of an inch the extent to which the heat-sealed seam opened within the marked edges of the heat-sealed area. Record this and any other evidence of failure of the seam or the adjacent material affected by the seam.

**7.           REPORT**

**7.1**           Immediately following each test the report (official record) of the facts pertinent to the test shall be completed, and shall include the following:

**7.1.1**         A statement that the test was conducted in compliance with this procedure, or a description of the deviations from this procedure. Report all options selected and details of otherwise specified procedure that were followed as permitted in 3.1, 3.3, 4.1, 4.2, 5.1, 6.1, and 6.3.

**7.1.2**         Identification of the specimen and the specific material tested.

**7.1.3**         Results of the test. Report the extent to which the seam opened and any other evidence of failure of the specimen.

**7.1.4**         When the test is performed to check compliance with requirements, state that the specimen did or did not meet the requirements and give the source for the requirements.

7.1.5 When the test is conducted to evaluate or compare products or methods, the report shall include a statement of any observations that may lead to improvements.

8. NOTES

8.1 If other weights or environments are to be used to evaluate the heat-sealed seams, they should be specified in the cognizant document.



## PUNCTURE RESISTANCE

### 1. SCOPE

1.1 This test is used to measure the load required to puncture flexible sheet materials. A probe moved at a relatively slow speed by means of a pendulum-type tensile testing machine, is used to puncture the specimen.

### 2. DEFINITION

2.1 Not applicable.

### 3. APPARATUS (The following equipment is required:)

3.1 A chamber or room maintained at  $73^{\circ} + 3.5^{\circ}\text{F}$  and  $50 \pm 5$  percent relative humidity in which to condition specimens and perform tests.

3.2 A chamber maintained at a temperature of  $160^{\circ} + 5^{\circ}\text{F}$  and  $85 \pm 5$  percent relative humidity in which to expose specimens to "accelerated aging."

3.3 A pendulum-type tensile testing machine having the following features:

- (a) A means of moving the stressing clamp at a uniform rate of  $12 \pm 1$  inches per minute.
- (b) The capacity of the machine shall be such that puncture of the specimen occurs when the pendulum hangs between  $9^{\circ}$  and  $45^{\circ}$  from the vertical.

3.4 A puncture fixture as shown in figures 1, 2, and 3.

### 4. SPECIMENS

4.1 Select specimens at random and in sufficient number to represent adequately the variation of the material.

4.2 A specimen shall be 10 inches in length by 4 inches in width. When the material being tested is orthotropic, specimens cut with length parallel to each principal direction shall be included in the tests.



5.           CONDITIONING

5.1           Unless otherwise specified, condition the specimens to equilibrium in an atmosphere uniformly maintained at  $73^{\circ} \pm 3.5^{\circ}\text{F}$  and  $50 \pm 5$  percent relative humidity, for a period not less than required for the specimen to attain a temperature and a moisture content in equilibrium with the conditioning environment. A period of 24 hours shall be considered adequate for this purpose.

5.2           Unless otherwise specified, prior to conditioning as specified in 5.1, expose one-half of the specimens to "accelerated aging" as follows: Expose the specimens 72 hours in a chamber maintained at  $160^{\circ} \pm 2^{\circ}\text{F}$  and  $85 \pm 5$  percent relative humidity. During exposure, the specimens shall be positioned to allow free circulation of air around each specimen.

6.           PROCEDURE

6.1           Perform tests in an atmosphere maintained at  $73^{\circ} \pm 3.5^{\circ}\text{F}$  and  $50 \pm 5$  percent relative humidity.

6.2           Fasten the puncture fixture in the lower clamp of the testing machine. Bring the 4-inch-wide ends of the specimen together to form a loop. If the faces of the specimen are of different materials, place on the inside of the loop that face normally placed facing the packaged product. Fasten the ends in the upper clamp of the testing machine, so that the center of the looped specimen is directly below the point of the probe. Operate the testing machine at  $12 \pm 1$  inch per minute until the puncture head has ruptured (punctured) the specimen. Record the load required to puncture the specimen.

7.           REPORT

7.1           Immediately following each test, report (official record) the facts pertinent to the test including the following:

7.1.1         State that the test was conducted in compliance with this procedure or describe any deviations from this procedure. Report options selected and details of otherwise specified procedures that were followed as permitted in 5.1 and 5.2.

7.1.2         Identify the specimens and the specific material tested.

7.1.3         Results of the test, State the load at rupture as determined in 6.2 after conditioning only and after "accelerated aging."

7.1.4         When the test is performed to check compliance with requirements, state that the specimens did or did not meet the requirements, and give the source for the requirements.

7.1.5 When the test is conducted to evaluate or compare products or methods, include a statement of any observations that may lead to improvements.

8. NOTES

8.1 Not applicable.

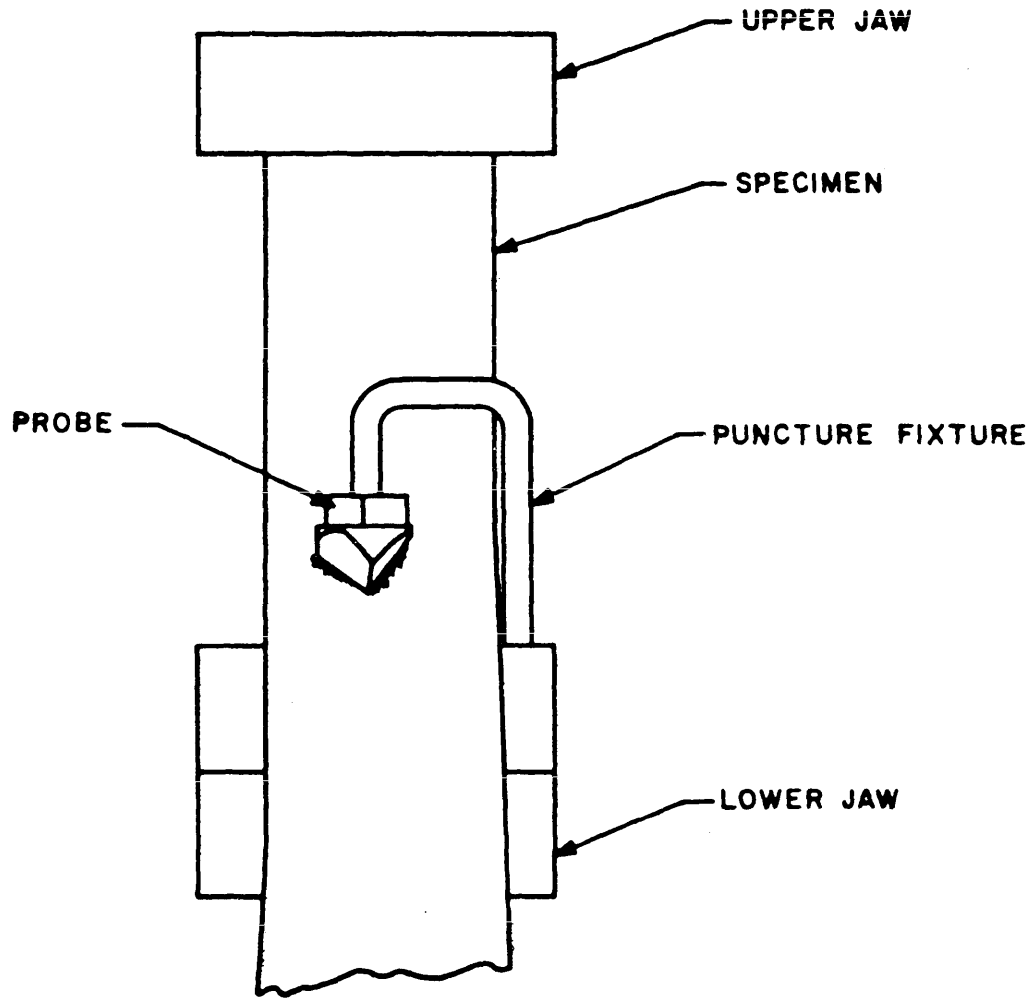
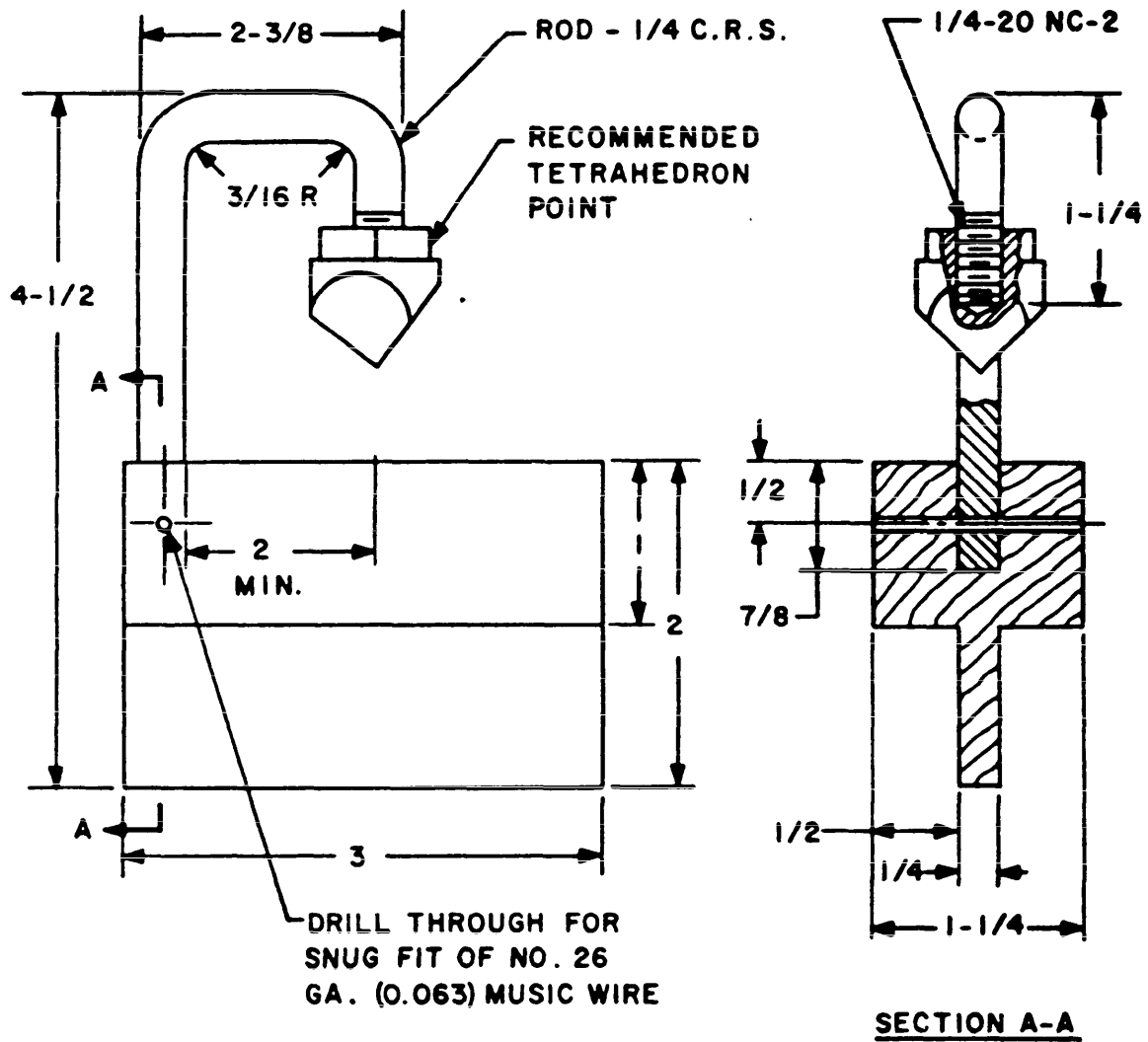
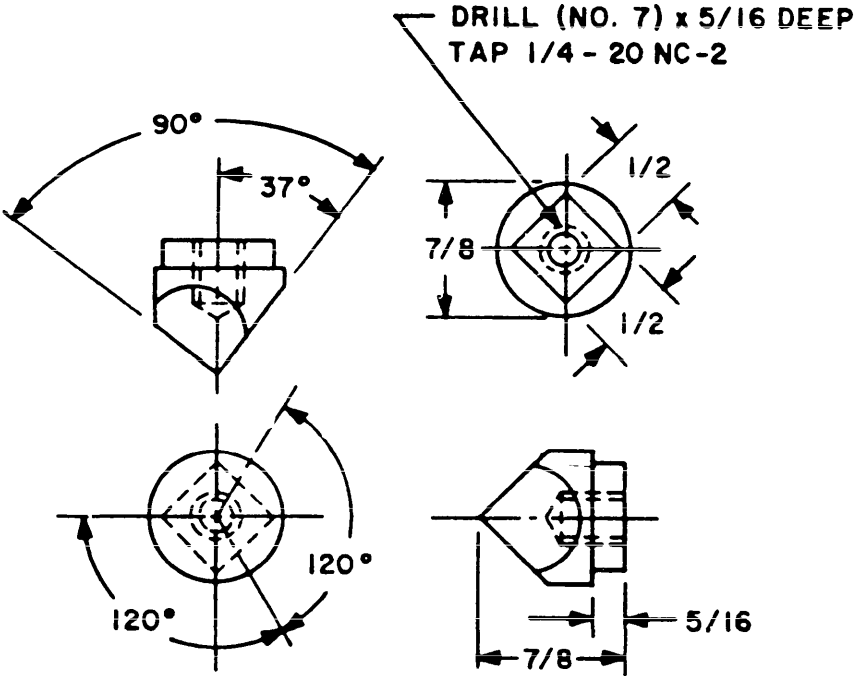

Figure 1. Puncture test assembly.



DIMENSIONS IN INCHES.

Figure 2. Puncture assembly.



DIMENSIONS IN INCHES.

Figure 3. Recommended tetrahedron point.

TENSILE BREAKING STRENGTH AND ELONGATION OF  
PAPER AND PAPERBOARD

NOTE: The test procedure TAPPI T-404-os-61 shall be used for determining the tensile breaking strength and, if required, the elongation of dry paper and paperboard. For wet paper and paperboard TAPPI T-456-m shall be used. A constant rate of movement of the loading clamps shall be maintained throughout the test of a specimen.



PUNCTURE RESISTANCE AND ELONGATION TEST  
(1/8 INCH RADIUS PROBE METHOD)

1. SCOPE
  - 1.1 This method is intended for use on flexible barrier materials, to determine their resistance to puncture (or rupture), and elongation, employing a 1/8 inch radius metal probe.
2. DEFINITIONS
  - 2.1 Not applicable.
3. APPARATUS
  - 3.1 Instron tensile tester equipped with compression head.
  - 3.2 Compression cells, C, D, E. Ranges 1 to 50 pounds, 20 to 1000 pounds, and 100 to 5000 pounds, respectively.
  - 3.3 Compression load cell table with accompanying adapter collar, size dependent upon compression cell range.
  - 3.4 Specimen cage (see figure 1), fabricated from four 4-inch threaded bolts and three 3-1/2 x 3-1/2 x 1/4 inch aluminum plates with 1/4 inch diameter hole drilled at each corner. The cage is assembled by inserting the bolts in the holes of one plate and anchoring them with a locking washer and nut. A one inch diameter hole is cut in the center of this plate to allow for attachment to the Instron tester crosshead by means of a threaded stud and metal disk. The remaining plates are anchored to the opposite ends of the bolts. A one inch diameter hole is cut in the center of these plates and two sheets of carborundum paper with corresponding one inch diameter holes in the center and with rough surfaces facing each other, are inserted between the two lower plates to hold the specimen during testing.
  - 3.5 A probe which is a 1/2 inch diameter, by five inches long, steel rod with one end tapered to a 1/8 inch radius on the end. The length of the taper is 2 inches. The probe is attached at its wider end to a 5-7/8 inch diameter aluminum plate (see figure 1) with 1/2 inch diameter hole drilled and threaded, in which the probe is mounted and secured with a nut. Two 1/8 inch diameter holes are drilled in the plate for attaching the probe assembly to the compression cell.
  - 3.6 A template, 2 inch by 2 inch for cutting test specimens.
  - 3.7 A dial gage or micrometer for measuring specimen thickness to nearest 0.0001 inch.



4. SPECIMENS

4.1 The specimens shall be selected from a representative area free of obvious flaws or defects. Specimens shall measure 2 by 2 inches.

5. CONDITIONING

5.1 Unless otherwise specified, condition the specimens for a minimum of 24 hours in an atmosphere maintained at  $73^{\circ} \pm 3.5^{\circ}\text{F}$  and  $50 \pm 5$  percent relative humidity. The surfaces of each specimen shall have access to the conditioning atmosphere.

6. PROCEDURE

6.1 Tests shall be conducted in an atmosphere as specified for conditioning.

6.2 Select a compression load cell covering the anticipated load required to puncture the test specimen. Lower the cell into the compression block with the power coupling side down. Based upon the load requirements, select the proper screw collar adapter to fit the cell and the compression table. Set the probe plate upon the compression table so that the holes are aligned and secure the plate and table together. Screw the probe into the probe plate and secure with a locking nut. Set the Instron Load Selector switch to the No. 5 position. With the load weighing system toggle switch in the "off" position connect the adapter wire first to the compression cell. Pass the wire up from behind the instrument and finally over the upper cross member for connection of the captive coupling to the load weighing system input connector. Energize the load weighing system, place the load selector switch to the No. 1 position for C compression cell operation, or to position 2 for D and E cell operation. Place the proper calibration weight on the probe plate, one, 10 or 25 pounds for Cell C, D and E respectively and proceed with instrument calibration. Deenergize the load weighing system. Return the load selector switch to position 5. Screw the connecting bolt on the top side of the specimen clamp assembly into the mating threaded hole in the center of the compression anvil located centrally and on the underside of the tester crosshead.

6.3 Determination of bursting strength

- (a) Using a dial gage, determine the specimen thickness at 5 pounds in the central 2-inch square area, and record the average thickness to within 0.00004 inch.
- (b) Loosen the 4 nuts on the periphery of the bird cage specimen holder and slip the specimen between the faces of the carborundum papers and hold down plates. Center the specimen in the clamping area so that it covers plate holes. Fix the specimen tightly into place by screwing down the nuts. Uniform tightening may be accomplished by progressive tightening of opposite pairs of nuts.

- (c) Using the crosshead down button, drive the crosshead to a point approximately 1 inch above the probe. Finally, using the manual positioning knob of the selsyn drive, adjust the crosshead such that the specimen test area and the probe tip are separated by 0.10 to 0.20 inch. Zero the gage length control dial.
- (d) Using a ruler, determine to the nearest 0.10 inch, the distance from the bottom flange of specimen clamp to the tip of the probe table. Set the gage length return dial to this distance in inches minus 0.2 inch. Set, to the left, and in the automatic return position, the toggle switch located directly below the red safety stop button and to the right of the traverse return button. Select the position of the selsyn drive gear box for the proper gear combination which, with the proper clutch level position, will provide a crosshead movement rate of 20 inches per minute.
- (e) Select and position in the chart drive gear box a gear combination to provide a chart speed of 20 inches per minute.
- (f) Record on the chart the average specimen thickness in inches, radius of the probe end in inches, crosshead and chart speeds in inches per minute.
- (g) Place the tester load selector switch in a position which will cover the anticipated load requirements and which, with the previously set chart speed, will provide a compression loading slope of approximately 45 degrees.
- (h) Activate the load weighing system. Energize the chart drive and simultaneously strike the crosshead down button.

CAUTION: Keep the test under constant surveillance to be certain first that the compression load is not being exceeded and secondly that the specimen clamp bed plate does not make direct contact with the compression cable.

- (i) When the specimen has been punctured, return the crosshead to its preset gage length point. Deactivate the load weighing and chart drive system. Loosen the nuts and remove the spent specimen. Place a new specimen in the specimen holder. Adjust the chart speed and load range, if required, to provide the desired slope on the records. Repeat the test procedure until five specimens have been tested.

6.4 From the records which have been stripped from the recorder, determine the maximum force in pounds, to the nearest 0.1 pound, required to puncture each specimen, and determine the elongation by measuring the distance to travel from the beginning of contact of probe with specimen to the puncture point to the nearest .01 inch.

7. REPORT

7.1 Immediately following each test, the report (official record) of the facts pertinent to the test shall be completed and shall include the following:

7.1.1 A statement that the test was conducted in compliance with this procedure, or a description of the deviations from this procedure. Report all options selected and details of otherwise specified procedure that were followed.

7.1.2 Identify the specimen and specific material tested and the average thicknesses.

7.1.3 Give results of test. Report the probe end diameter, force required for each determination as well as the average force for five determinations. Also, if required, report the corresponding elongation for each specimen and the average for the specimens.

7.1.4 When the test is performed to check compliance with requirements, state that the specimen did or did not meet the requirements, and give the source for the requirements.

7.1.5 When the test is conducted to evaluate or compare products or methods, include in the report any observations that may lead to improvements.

8. NOTES

8.1 Not applicable.

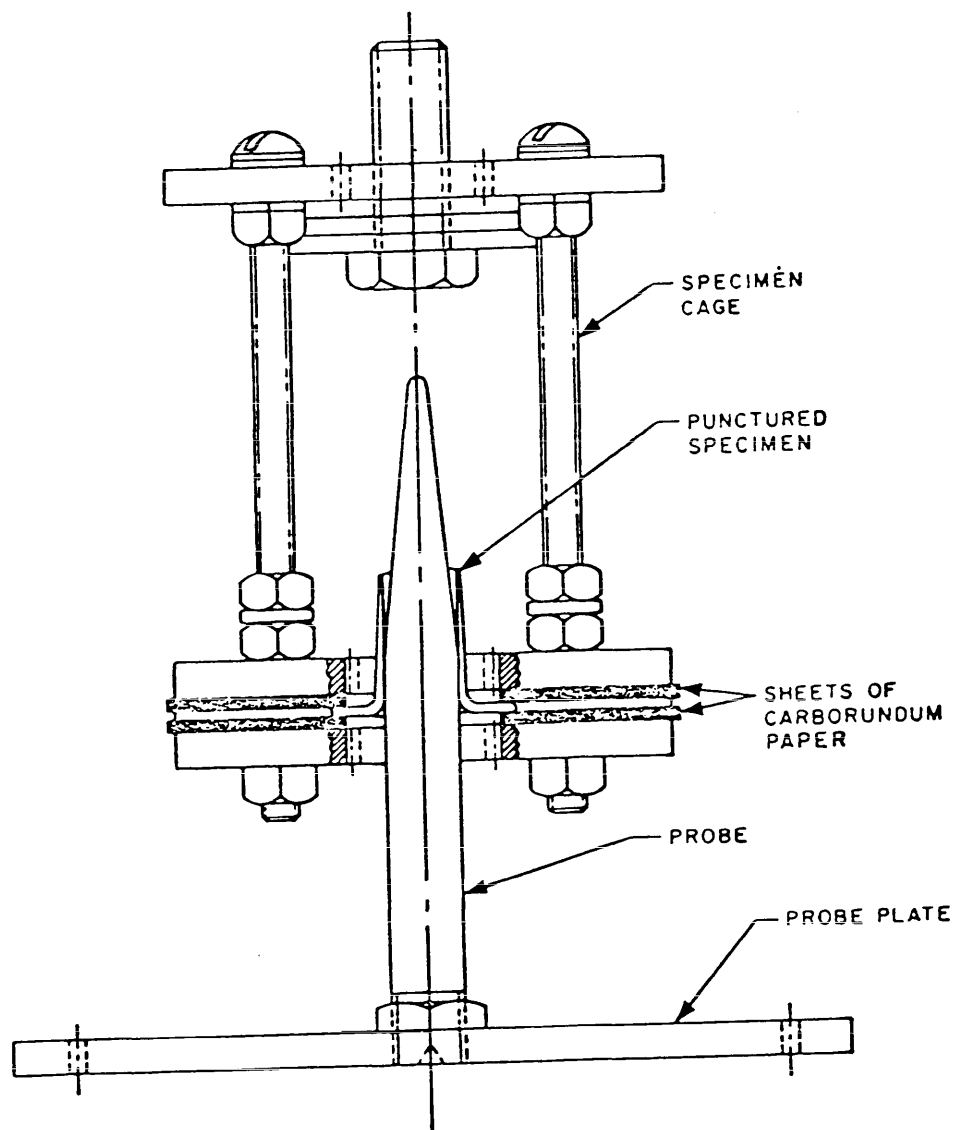

Figure 1. Puncture resistance and elongation test fixture.



## BLOCKING RESISTANCE OF PACKAGING MATERIALS

### 1. SCOPE

1.1 This method of test includes procedures for determining the blocking resistance of packaging materials, including (A) films and papers; impregnated, coated, laminated, or coated and laminated combinations of paper with metallic foils and synthetic films; (B) gummed paper labels, (C) tapes including those with filament reinforcement but not including pressure-sensitive tape; and (D) pouches.

1.2 Procedure A is a general method applicable to those packaging materials other than gummed labels and tapes where blocking may be detrimental. This method provides for a range of standard conditions of temperature and relative humidity to simulate the varying climatic conditions which the materials might encounter during manufacture, storage, transportation, or use.

1.3 Procedure B is designed specifically for gummed labels to ascertain if blocking will occur between the adhesive and paper.

1.4 Procedure C is designed for gummed tapes to determine if blocking will occur between the adhesive and adjacent tape backing.

1.5 Procedure D is designed for pouches of the materials that are commonly fabricated or stocked in the form of pouches.

### 2. DEFINITIONS

2.1 Blocking is defined as cohesion or adhesion between contiguous layers of similar or dissimilar materials in roll or sheet form which interferes with the satisfactory and efficient use of the material.

2.2 Blocking resistance is defined as the ability of a given material to resist the blocking effects of temperature, pressure, and relative humidity.

2.3 Equilibrium. The specimen shall be considered at equilibrium when the change in weight during a 1-hour or longer period of conditioning does not exceed 0.02 percent of the specimen's weight at the end of the period.

### 3. APPARATUS

3.1 The general apparatus shall consist of the following:

**METHOD 3003**  
**March 13, 1980**

3.1.1 A constant temperature oven with provisions for air circulation that can be maintained at selected temperatures between 100° and 160°F within  $\pm 2^\circ\text{F}$ .

3.1.2 A desiccator, for use as a humidity chamber, having a minimum inside diameter of 6 inches. Ground glass edges should be flat, clean, and freshly lubricated with a thin film of stopcock grease.

3.2 For procedures A and B special apparatus shall include:

3.2.1 A bottom supporting plate consisting of a 4- by 4-inch piece of plate glass or a corrosion-resistant metal plate with flat surfaces.

3.2.2 Pressure blocks. Four brass plates or weighted pieces of corrosion-resistant metal or plate glass having flat surfaces, with base dimensions equal to or slightly larger than the dimensions of the specimens. The weight of each block or weighted plate shall be such that it will provide a pressure on the bottom support surface equivalent to the specified pressure. Unless otherwise specified, base dimensions shall be  $1.50 \pm 0.01$  inches square and the weight shall be sufficient to create a uniform pressure of  $0.5 \pm 0.01$  p.s.i.

3.3 For Procedure A special apparatus shall include:

3.3.1 Sheets of thin hard surfaced paper or thin metal foil cut to the size of the specimen.

3.4 For Procedure B special apparatus shall include:

3.4.1 Sheets of bond paper conforming to type III of UU-P-121 cut to a size of 2 by 2 inches.

3.5 For Procedure C special apparatus shall include:

3.5.1 Two plane-surfaced corrosion-resistant metal blocks 1 by 4 by 1/2 inches.

3.6 For Procedure D special apparatus shall include:

3.6.1 Resilient pads 2 inches square and 1/8 inch thick.

3.6.2 Smooth, flat surfaced plates of glass or metal 5 inches square and weighing less than 1/4 pound.

3.6.3 The combined pressure of the plate and weights shall be 12 pounds.

#### 4. SPECIMENS

4.1 Unless otherwise specified, specimens shall be taken at random in sufficient number to adequately represent the variation within the material.

4.2 When the number and size of specimens are not otherwise specified, the specimens for each procedure shall consist of:

4.2.1 A representative piece of the sheet material approximately 1.5 inches square shall constitute a specimen. A group of eight specimens is required for one test. (This size permits four tests to be exposed simultaneously in a 6-inch-diameter desiccator. When tests do not involve a desiccator for humidity control, the specimen size may be larger.)

4.2.2 Procedure B: Twenty labels. If either dimension is larger than 2 inches, cut it to 2 inches.

4.2.3 Procedure C: Ten strips of tape, 4 inches long by 1 inch wide or less when the width of the roll of tape is narrower than 1 inch.

4.2.4 Procedure D: Pouches.

4.2.4.1 From sheet material four 5- by 10- inch sheets shall be cut out and subjected to the conditioning atmosphere prescribed in 5.3.1 for not less than 16 hours before fabrication into pouch specimens. Form each sheet into a 5- by 5-inch pouch by folding in half and, leaving one side open, seal along three sides with a seam 1/2 inch wide using the method contemplated for use of the material.

4.2.4.2 From pouches or bags submitted in the fabricated form, four representative pouches of the same size shall constitute the specimens for each test.

#### 5. CONDITIONING

5.1 The surfaces of specimens shall have unimpaired exposure to the conditioning environment or series of environments as specified.

5.2 Unless otherwise specified, the period of conditioning shall be not less than required for the specimen to attain a temperature and a moisture content in equilibrium with the conditioning environment (see 2.3).

5.3 Unless otherwise specified, the conditioning environment for each procedure shall be as follows:



METHOD 3003  
March 13, 1980

5.3.1 Procedures A and D:  $73^{\circ} \pm 3.5^{\circ}\text{F}$  and  $50 \pm 2$  percent relative humidity.

5.3.2 Procedures B and C:  $73^{\circ} \pm 3.5^{\circ}\text{F}$  and  $80 \pm 2$  percent relative humidity. The 80 percent relative humidity can be obtained with a saturated solution of ammonium sulfate in a desiccator at the specified temperature.

5.4 The paper sheets which are to be used as special apparatus in Procedures A and B shall also be conditioned as specified for the test specimens in the respective procedures.

6. PROCEDURE

6.1 Procedure A.

6.1.1 Procedure A consists of stacking the specimens and applying a pressure which is maintained while the stack is exposed to a controlled environment. After a period of exposure, the specimens are separated and rated for blocking resistance.

6.1.2 The exposure environment (temperature and relative humidity, and the pressure) shall be as specified for the determination of blocking resistance. If not specified, the selection of the test environment may be at the option of the testing activity (see 8.2).

6.1.3 The apparatus, including the desiccator containing the proper salt solution, the pressure blocks, supporting plates, and interleaving material shall be brought to the test temperature by heating them for at least 1 hour in the oven which previously has been adjusted to the exposure temperature. When the desiccator is warmed, open its lid for about 5 minutes and then close the lid until the specimens are ready for insertion.

6.1.4 Stack the conditioning test specimens and pressure media in the desiccator or in the oven in the following sequence:

Bottom supporting plate.  
Interleaving paper or foil.  
Four test specimens (stacked one on top of the other).  
Interleaving paper or foil.  
Four test specimens (stacked one on top of the other).  
Interleaving paper or foil.  
Pressure block.

6.1.5 If the faces of the test specimens are of different characteristics, the test specimens shall be stacked so that all three possible surface combinations - face to face, face to back and back to back - are tested. The following sequence shall be used:

Bottom supporting plate.  
Interleaving paper or foil.  
One specimen, face up.  
One specimen, face down.  
One specimen, face down.  
One specimen, face up.  
Interleaving paper or foil.  
One specimen, face up.  
One specimen, face down.  
One specimen, face down.  
One specimen, face up.  
Interleaving paper or foil.  
Pressure block.

6.1.6 A 6-inch-diameter desiccator will permit four stacks to be tested at one time. Locate each stack in a quarter section of the bottom supporting plate so that the individual stacks do not overlap or touch each other and so that the test areas are completely supported by the bottom plate. For exposure conditions involving dry heat, the stacks including the bottom plate can be placed directly on a shelf in the oven.

6.1.7 Place the desiccator containing the stacked test specimens or the stack of specimens (if dry heat is involved) in the oven. Let the lid of the desiccator remain partially open for 15 minutes, then slide it shut. Leave the desiccator or the stack of specimens in the oven at the exposure temperature for  $24 \pm 1$  hour unless otherwise specified.

6.1.8 Remove the desiccator or the stack of specimens from the oven and then carefully remove the pressure blocks from the stack of test specimens and take each stack from the desiccator.

6.1.9 Allow the stack of test specimens to stand in an atmosphere maintained at  $73^{\circ} \pm 3.5^{\circ}$  F and  $50 \pm 2$  percent relative humidity for a cooling period of at least 30 minutes.

6.1.10 After the cooling period the specimens shall be examined, by slipping or peeling the sheets apart, and rated for blocking resistance as follows:

Degree of blocking resistance	Description of blocking
No blocking	No adhesion or cohesion between contiguous surfaces, which slide freely upon one another. Surfaces of specimens are not marred.

METHOD 3003  
March 13, 1980

Degree of blocking resistance	Description of blocking
Slight blocking	Slight adhesion. Adjacent surfaces do not slide freely, but will with frictional pressure. Surface may or may not show a very slight evidence of marring. Include surfaces that may be easily separated with no evidence of delamination or rupture and show little or no evidence of marring, even though it may be difficult to cause the surfaces to slide.
Considerable blocking	Adhesion or cohesion of contiguous surfaces. Layers may be separated with difficulty. Surfaces will be marred or partially destroyed. Paper base materials will show loss of fiber. Synthetics may or may not display surface mar.
Complete blocking	Blocking to the extent of a complete seal or weld between adjacent surfaces which cannot be separated without destruction of the test specimen.

6.2 Procedure B (gummed labels).

6.2.1 Stack the conditioned specimens on a supporting plate evenly with each specimen one on top of the other and interleaved with a conditioned sheet of the bond paper.

6.2.2 The stack shall be weighted to a uniform pressure of  $0.5 \pm 0.01$  p.s.i. on the surface of the specimen.

6.2.3 The stack of assembled specimens shall be placed in the test atmosphere ( $73^{\circ} \pm 3.5^{\circ}\text{F}$  and  $80 \pm 2$  percent relative humidity) and retained therein for a 24-hour period.

6.2.4 The stack shall then be moved, with pressure still applied, into an atmosphere maintained at  $73^{\circ} \pm 3.5^{\circ}\text{F}$  and  $50 \pm 2$  percent relative humidity and retained therein for a period of at least 24 hours.

6.2.5 Then the stack shall be disassembled and the specimens examined for adherence of the adhesive on the label to the bond paper. When a label cannot be easily separated without removing fibers from the interleaving sheet, it shall be recorded as blocked.

7. REPORT

7.1 Immediately following each test the report (official record) of the facts pertinent to the test shall be completed, and shall include the following:

7.1.1 A statement that the test was conducted in compliance with this procedure, or a description of the deviations from this procedure. Report all options selected and details of otherwise specified procedure that were followed as permitted in 3.2.2, 4.1, 5.2, 5.3, 6.1.2, and 6.4.2.

7.1.2 Identification of the specimen and the specific material tested.

7.1.3 Results of the test. For Procedures A and D report the degree of blocking resistance and identify the surfaces rated. Include a brief description of any blocking found. For Procedure D also report, when the 200 gram weight is used to separate the interior surfaces, the period of time that the weight remained suspended. For Procedure B and C report for each specimen whether or not its adhesive was found blocked to adjacent material.

7.1.4 When the test is performed to check compliance with requirements, state that the specimen did or did not meet the requirements and give the source for the requirements.

7.1.5 When the test is conducted to evaluate or compare products or methods, the report shall include a statement of any observations that may lead to improvements.

8. NOTES

8.1 Details are given with the qualification, "unless otherwise specified," in the paragraph regarding:

Pressure blocks (3.2.2).  
Specimens (4.1 and 4.2).  
Conditioning (5.2 and 5.3).  
Exposure (6.1.2 and 6.4.2).

8.2 The temperatures and humidities required in current specification range from 100<sup>0</sup> to 180<sup>0</sup>F and from 0 to 75 percent relative humidity. Pressures are usually either 0.5 or 3 p.s.i. The periods of exposure range from 1/2 to 48 hours, but 24 hours is the most common. ASTM, TAPPI, and P.I. procedures state that one or more of the following sets of conditions shall be used to test for blocking.

**METHOD 3003**  
**March 13, 1980**

**6.3 Procedure C (gummed tapes).**

**6.3.1** The ten conditioned specimens shall be arranged adhesive side downward in a precise stack on one metal block, and the stack covered by the second metal block.

**6.3.2** The stack shall be weighted to a uniform pressure of  $0.5 \pm 0.01$  p.s.i. on the surface of the specimen.

**6.3.3** The stack of assembled specimens shall be placed in the test atmosphere ( $73^{\circ} \pm 3.5^{\circ}\text{F}$  and  $80 \pm 2$  percent relative humidity) and retained therein for a 24-hour period.

**6.3.4** After exposure to the test atmosphere, the top block shall be removed and the individual strips of tape separated and examined for blocking. When a tape specimen cannot be easily separated from another without removal of fibers or material from the backing of the adjacent strip, or delamination of the tape, it shall be recorded as blocked.

**6.4 Procedure D (pouches).**

**6.4.1** A 2- by 2- by 1/8 inch-thick resilient pad shall be placed on a smooth hard plate. A conditioned pouch specimen shall then be placed upon the pad so as to be centered thereover. Place three additional pouches centered upon the first pouch to build a stack of four pouches. Place a resilient pad centered upon the top pouch and cover with the smooth hard plate. Then add the weight to apply a uniform pressure of 3 pounds per square inch to the portion of each specimen between the two pads.

**6.4.2** The entire assembly shall then be placed in an oven maintained, unless otherwise specified, at  $160^{\circ} \pm 2^{\circ}\text{F}$  for 24 hours. Then the entire assembly shall be removed and allowed to come to room temperature.

**6.4.3** The assembly shall then be dismantled and the specimens shall be examined and rated as described in 6.1.10 for blocking, pouch to pouch. Then each pouch shall be examined by cutting away the seamed edges and determining the extent of blocking between interior surfaces of the pouch.

**6.4.4** If blocking is indicated by resistance to separation of the two interior surfaces, a free end of one surface shall be clamped so the blocked surface hangs down freely in a vertical position. A 200 gram weight shall then be gently attached to the corresponding free end of the opposite surface. Either determine the time that the weight is sustained until complete separation of the surfaces occurs, or if the time exceeds 2 minutes, report the specimens blocked. Visually inspect the separated surfaces for delamination or rupture of the material.



CONTACT CORROSIVITY TEST OF SOLID MATERIALS IN  
FLEXIBLE, RIGID, OR GRANULAR FORMS

1. SCOPE

1.1 This test method contains four procedures, each of which is intended to determine whether or not a packaging material while retained in intimate contact with a test surface induces corrosion of the test surface. The determination may be made for fresh material, or for material subjected to a prescribed procedure of conditioning before test.

2. DEFINITIONS

2.1 Corrosion. Deterioration of a material by chemical action, usually as a result of oxidation, galvanic, acid, or alkali action. In this test method a visible change in the surface finish such as pitting or etching or the formation of loose or granular particles shall constitute corrosion. Stain alone shall not be considered corrosion.

2.2 Stain. Color changes formed only on a surface without any evidence of rust, pitting, etching, or deterioration of the surface. In this test stain shall not be considered corrosion.

2.3 Test surface. A specially prepared surface of the material to be retained with the specimen in the test environment and subsequently examined for evidence of corrosion.

3. APPARATUS

3.1 A slow-speed grinding and polishing wheel and a supply of 240 grit aluminum oxide or silicon carbide abrasive.

3.2 Tanks for cleaning, rinsing solvents, and fingerprinting removal.

3.3 A ventilated drying oven with a temperature control or a bank of infrared lamps.

3.4 Desiccator with drying agent.

3.5 An exposure chamber with a temperature control and a system for controlling relative humidity, if required.

METHOD 3005  
March 13, 1980

3.6 Rectangular steel weights 1 by 1 by 3 inches weighing  $0.85 \pm 0.05$  pound unless otherwise specified.

3.7 For granular solids not bagged, a grinder capable of reducing the particle size of test material; two sieves, U.S. No. 40 and No. 80; and glass microslides, 1 by 3 inches.

3.8 Test surface.

3.8.1 Unless otherwise specified in the reference to this test method, the test surface shall be prepared as follows on a 1/8- by 2-by 4-inch panel of low carbon steel, QQ-S-698, condition 5. When aluminum is specified, use a 1/8- by 2- by 4-inch panel of aluminum alloy, 2024 bare, of QQ-A-250/4.

3.8.2 Test surface preparation. Each panel shall be ground to remove surface scale, pits, and other irregularities from all surfaces. One of the large flat surfaces of the panel shall then be finished with 240 grit aluminum oxide or silicon carbide abrasive to a surface roughness of 6 to 12 microinches (RMS) for the test surface. The use of iron oxide abrasives, and any abrasive paper that leaves residues not removable by the following cleaning method is prohibited. Some abrasive papers that are intended to be used dry or wet have been found to leave such residues. Each metal panel shall be wiped with surgical gauze and then scrubbed with a brush or gauze swab in a tank or container of hot mineral spirits conforming to grade 1 of TT-T-291. This shall be followed by successive immersions in hot mineral spirits, boiling 95 percent methanol and boiling absolute methanol, allowed to dry in clean air or placed in a ventilated clean drying oven; and then stored in a desiccator until ready for use.

CAUTION

Methanol vapor is harmful to personnel.  
Proper ventilation must be provided in  
work areas where it is used.

3.8.3 If the panels are stored in the desiccator for a period of more than 24 hours, the latter portion of the surface preparation shall be repeated starting with the 240 grit finishing.

CAUTION

During and after cleaning, the test panels  
shall be handled only with clean lint-free  
gloves, forceps, or other means to prevent  
contamination of the test surface.



4. SPECIMENS

4.1 Unless otherwise specified, specimen shall be selected at random and in sufficient number to adequately represent the material to be evaluated. Cautions shall be taken as necessary to prevent contamination of specimens.

4.2 Forms of material.

4.2.1 In flexible sheet form, a specimen shall be a piece of the material 2 by 3 inches.

4.2.2 In more rigid or solid form, such as cushioning or blocking, a specimen shall be rectangular with dimensions of a flat surface representative of the material not less than 1 by 3 inches.

4.2.3 In granular form, a specimen shall be about 20 grams of material ground so that it passes a U.S. No. 40 sieve but is retained on a U.S. No. 80 sieve. For bagged material such as desiccant, the specimen shall be a single unit bag of the material.

5. CONDITIONING

5.1 The surfaces of each specimen shall have free access to the conditioning atmosphere. Unless otherwise specified, condition the specimens to equilibrium in an atmosphere uniformly maintained at  $73^{\circ} \pm 3.5^{\circ}\text{F}$  and  $50 \pm 5$  percent relative humidity, for a period not less than required for the specimen to attain a temperature and a moisture content in equilibrium with the conditioning environment. A period of 24 hours shall be considered adequate for this purpose.

5.1.1 A desiccant specimen shall be conditioned at  $77^{\circ} \pm 2^{\circ}\text{F}$  and  $60 \pm 2$  percent relative humidity for not less than 24 hours.

6. PROCEDURE

6.1 The specimen shall be placed in intimate contact across a portion of the test surface (figure 1). The edges of the contact area shall be marked on the edges of the panel.

6.1.1 A 2- by 3-inch flexible sheet specimen shall be placed across the central portion of the test surface of the panel, as shown in figure 1a. A glass slide with a mounting bar superimposed and coinciding shall be centered on top of the specimen with the longitudinal centerline of the slide and bar coinciding with that of the film (figure 1b).

METHOD 3005  
March 13, 1980

6.1.2 A more rigid specimen, such as cushioning or blocking, shall be placed across the central portion of the test surface so that the specimen extends over the edges of the panel. Large specimens shall be placed off center so an area of the test surface not less than 2 by 2 inches shall remain uncovered. The steel weight (1 inch thick) shall be superimposed on the specimen.

6.1.3 A granular specimen shall be placed and leveled between parallel lines 1 inch apart across the central portion of the test surface of a panel. The specimen shall be covered with a glass slide, and the steel weight shall be placed upon the glass slide.

6.1.4 A specimen of bagged granular material shall be placed upon the test surface of a panel so that an area of the test surface not less than 2 by 2 inches shall remain uncovered. If necessary, a larger clean glass plate may be used to support the test surface panel and the overhanging portion of the bagged specimen.

6.2 The specimen and test surface arranged as prescribed in 6.1 then shall be retained in the exposure environment for the required period of time. Unless otherwise specified, the exposure shall be for 1/2 hour in air maintained at a temperature of  $150^{\circ} \pm 5^{\circ}\text{F}$  followed immediately by exposure in air at  $120^{\circ} \pm 2^{\circ}\text{F}$  and  $65 \pm 3$  percent relative humidity for either 20 hours if the test surface is steel or 72 hours if the test surface is aluminum (see note 8.1).

6.3 At the end of the exposure period, separate the specimens from the test surface and immediately examine the test surface for evidence of corrosion. Record for each area—the one covered by the specimen, and the other not covered—whether or not corrosion occurred and a description including the severity and distribution of any corrosion.

## 7. REPORT

7.1 Immediately following each test the report (official record) of the facts pertinent to the test shall be completed, and shall include the following:

7.1.1 A statement that the test was conducted in compliance with this procedure, or a description of the deviations from this procedure. Report all options selected and details of otherwise specified procedures that were followed as permitted in 3.6, 3.8, 4.1, 5.1 and 6.2.

7.1.2 Identification of the specimen, the specific material, and the face tested. Also identify the test surface material.

7.1.3 Results of the test. State whether or not the specimen induced corrosion of the test surface material.

7.1.4 When the test is performed to check compliance with requirements, state that the specimen either did or did not meet the requirements and give the source for the requirements.

7.1.5 When the test is conducted to evaluate or compare products or methods, the report shall include a statement of any observations that may lead to improvements.

## 8. NOTES

8.1 The given exposure environment and duration are such that corrosion will not be visible on unprotected clean steel or aluminum, but corrosion will be visible on the test surface if the material under test has a tendency to induce corrosion. When test surfaces are of other metals, the exposure should be specified. To establish whether or not a specimen induces corrosion of a test surface other than steel or aluminum, the severity of the test environment and duration of exposure thereto must be sufficient to closely approach incipient corrosive attack of the bare (control) specimen surface. This will require a preliminary test to establish the appropriate duration of exposure.

8.2 Details are given with the qualification, "unless otherwise specified," in the paragraphs regarding:

Weights (3.6).  
Test surface (3.8).  
Specimens (4.1).  
Conditioning (5.1).  
Exposure (6.2).

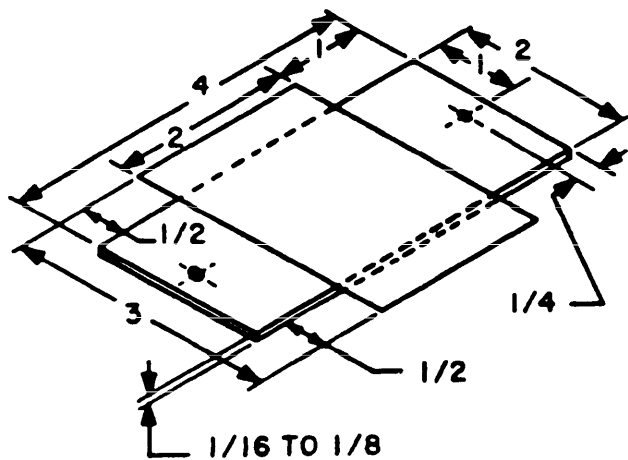

Figure 1a. Method of specimen application.

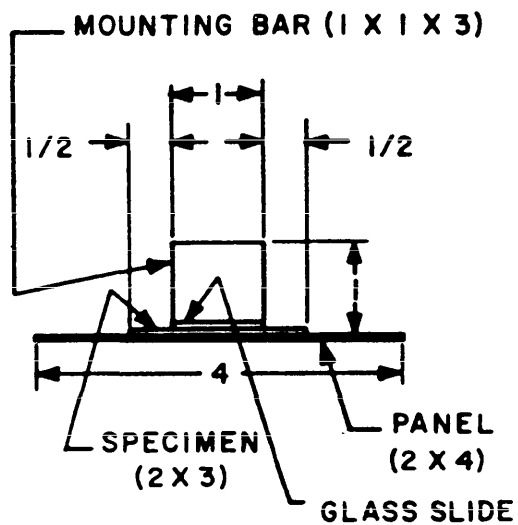

Figure 1b. Test assembly.

DIMENSIONS IN INCHES.

Figure 1. Contact corrosivity components.

DELAMINATION RESISTANCE OF HEAT-SEALABLE FILMS AND BARRIERS

PROCEDURE A

1. SCOPE

1.1 This method is designed to determine the resistance of a material to delaminate in the presence of oil.

2. DEFINITIONS

2.1 This test method shows the ability of a material to prevent oil leakage and to resist deterioration such as delamination, swelling, or embrittlement when the heat-sealable face is in contact with oil.

3. APPARATUS

3.1 The apparatus shall consist of the following:

3.1.1 A chamber or room maintained at  $73^{\circ} \pm 3.5^{\circ}\text{F}$  and  $50 \pm 5$  percent relative humidity.

3.1.2 An oven capable of maintaining a temperature of  $160^{\circ} \pm 2^{\circ}\text{F}$ .

3.1.3 Reagent. The type 6 oil specified in TT-S-735. (This is comparable to ASTM Oil No. 3.) Also when specified, di-2-ethylhexyl sebacate (C. P. Hall Company's MULTIPLEX DOS).

3.1.4 A metal pan or tray to catch the oil that might seep through the specimens during the test period.

3.1.5 Two 3- by 6-inch smooth flat metal sheets approximately 1/4 inch thick.

3.1.6 Two 18-pound weights.

3.1.7 A heat sealer equipped with controls for temperature, dwell time and pressure.

4. SPECIMENS

4.1 Unless otherwise specified, specimens shall be taken at random and in sufficient number to adequately represent the variation within the material. When the number and size of specimens are not otherwise specified, not less than five specimens, 3 by 6 inches, shall be used with each reagent.

## 5. CONDITIONING

5.1 The surfaces of specimens shall have unimpaired exposure to the conditioning environment or series of environments as specified.

5.2 Unless otherwise specified, the specimens shall be conditioned at  $73^{\circ} \pm 3.5^{\circ}\text{F}$  and  $50 \pm 5$  percent relative humidity for a period not less than required for the specimen to attain a temperature and a moisture content in equilibrium with the conditioning environment.

## 6. PROCEDURE

### 6.1 Pouch preparation.

6.1.1 Fold each test specimen in half, heat-sealable face to heat-sealable face, to give a 3- by 3-inch specimen.

6.1.2 Make a sharp crease in the specimen by placing the folded specimen between the two smooth flat metal plates and applying one of the 18-pound weights, exerting a pressure of approximately 6 pounds per inch of crease, on top of the fold for 30 seconds.

6.1.3 Unfold the specimen and recrease in a similar manner (heat-sealable face to heat-sealable face) at right angles to the first crease by placing the specimen between the two smooth flat plates again and applying both 18-pound weights side by side on top of the fold for 30 seconds.

6.1.4 Make a 3- by 3-inch pouch by folding the sample in half along the first crease and seal along the two sides, using a suitable temperature, dwell time, and pressure previously determined for the material. The seal shall be 1/2 inch in width, uniform and continuous.

### 6.2 Exposure to oil.

6.2.1 Pour into each pouch approximately 5 ml of oil, carefully keeping the sealing area free from oil and the enclosed air to a minimum, and seal the end of the pouch.

6.2.2 Promptly expose the pouches in the oven (maintained at  $160^{\circ} \pm 2^{\circ}\text{F}$ , unless otherwise specified) for 24 hours by hanging each pouch from the center of its sealed end. Place the pan or tray under the pouches to catch any possible oil seepage.

6.2.3 Remove the pouches from the exposure environment and allow them to come to room temperature. Examine the pouches for the sources of any oil leakage. If most of the oil in a pouch was lost through the heat-sealed joints during the exposure period, this fact shall be recorded, the pouch shall be discarded, and an additional pouch shall be prepared and tested.

### 6.3 Examination of material.

6.3.1 Cut off the three sealed edges, and remove the oil remaining in the pouch. Pull the sheet taut and examine for evidence of swelling,

delamination, embrittlement, or other visible defects. A test for delamination of the face film shall be conducted at midlength of the test specimen by placing the specimen between the thumbs and forefingers so that the thumbs rest on the heat-sealable face. The thumbs shall then be thrust forward and outward in a finger-snapping motion in such a manner that the heat-sealable face will delaminate if it is loosely bonded. Record any observed effects of the exposure to oil.

## 7. REPORT

7.1 Following the test, a report shall be written which shall include:

7.1.1 A statement that the test was conducted in compliance with this procedure or a description of the deviation from this procedure. Report all options selected and "otherwise specified" details that are followed as permitted in 4.1, 5.2 and 6.2.2.

7.1.2 Identify the specimens and the specific material represented by the specimens.

7.1.3 Report whether or not there was any leakage from the pouch (disregarding seepage through the heat-sealed joints), evidence of swelling, delamination, embrittlement, or other visible defects.

7.2 When a performance requirement is specified, state that the specified performance was attained, or state that the specified performance was not attained.

## 8. NOTES

8.1 When di-2-ethylhexyl sebacate is specified for testing the oil resistance of heat-sealable packaging materials, the test procedure shall be repeated and the di-2-ethylhexyl sebacate shall be used instead of the oil specified in 3.1.3. It may be obtained from C. P. Hall Company, Chicago, IL under the trade name of MULTIPLEX DOS.

METHOD 3015.2  
CHANGE NOTICE 3  
14 OCTOBER 1988

PROCEDURE B

ASTM F119-76 GREASE PENETRATION OF FLEXIBLE BARRIER MATERIALS

1. SCOPE

1.1 When specified in the commodity specification, contract or order, Procedure B may be used in lieu of Procedure A for heat-sealable films and barriers.



RATE OF PENETRATION OF PACKAGING MATERIALS  
BY WATER

1. SCOPE

1.1 This method determines the rate at which water passes through a sheet of material by sealing the material over a dish containing desiccant, submerging the dish in water, and determining the gain in weight during the time submerged.

1.2 This method makes no differentiation between water and water vapor that penetrates the material.

1.3 For determining the water-penetration rate of pressure-sensitive tapes use Fed Std Test Method 101/3032.

2. DEFINITIONS

2.1 Not applicable.

3. APPARATUS

3.1 Container with clean water in which the specimen dishes can be immersed so the test material is under 1 inch of water pressure.

3.2 Anhydrous calcium chloride desiccant. Reagent grade, Mesh No. 8.

3.3 Weighing balance accurate to 0.01 g.

3.4 Specimen dishes. Thwing-Albert Vapometer or similar specimen dishes to contain desiccant and to be closed by the test material. (See ASTM E96-53T.)

3.5 Wax for sealing sheet materials to dish. Mobilwax 2300 or 2305 made by Mobil Oil Company or equivalent wax is usually satisfactory. For tests at 100 F the wax shall have a melting point between 130° and 160 F. Beeswax is suitable.

4. SPECIMENS

4.1 Unless otherwise specified, specimens shall be taken at random and in sufficient number to adequately represent the variation within the material. Specimens of sheet materials shall be trimmed to fit the specimen dishes.

METHOD 3019.1  
March 13, 1980

4.1.1 Unless otherwise specified, a specimen of coating compound shall be a layer of the compound approximately 1/8 inch thick (wet) applied uniformly on a 6- by 6- inch sheet of grade 2, 80-pound basis weight kraft wrapping paper conforming to UU-P-268. After a 96-hour drying period, the coated sheet shall be trimmed to fit the specimen dish.

5. CONDITIONING

5.1 Unless otherwise specified, no special conditioning of the specimens is required.

6. PROCEDURE

6.1 Place not less than 20 g. of anhydrous calcium chloride desiccant in the test dish immediately before attaching the specimen. The desiccant shall fill the dish to a level about 1/8 inch below the level of the specimen.

6.2 Promptly after placing the desiccant in the dish, attach the specimen to the dish to seal the desiccant chamber.

6.2.1 For sheet materials use wax on the periphery of the specimen to exclude water from the cut edges and to insure an impervious seal to the dish. Wax shall not be permitted upon the area of the specimen that closes the opening to the dish. Weigh the assembly to 0.01 g. to establish its initial weight.

6.3 Submerge the specimen dishes so the test material is under 0.9 to 1.0 inch of water at the test temperature specified or, if not otherwise specified, at room temperature. (The water and container shall be preconditioned to the test temperature.) Maintain the test temperature of the specimen dishes and water within a maximum variation of  $\pm 3.5^{\circ}\text{F}$  throughout the immersion period. Unless otherwise specified, the immersion period shall be 48 hours for coated sheet materials. However, if during the immersion period the desiccant gains in weight more than its absorptive capacity at 20 percent relative humidity the test shall be repeated using either a shorter immersion period or a greater quantity of desiccant in a deeper dish.

6.4 Determine the weight gain during the immersion period. The specimen dish shall be removed from the water and the exterior surfaces (dish and test material intact) shall be gently wiped dry and further dried in an oven. After 30 minutes of drying at  $100^{\circ}\text{F}$  weigh the assembly. From this final weight subtract the initial weight to determine the weight gain during the period of immersion.

6.5 Observe the specimen and record any indications of degradation.

## 6.6 Computation

6.6.1 Compute the rate of water penetration in g. per 100 square inches per 24 hours by the following expression:

$$\text{Rate of water penetration} = \frac{\text{Weight gain (grams)} \times 2,400}{\text{Immersion period (hr.)} \times \text{area exposed (sq. in.)}}$$

Area is the surface of the desiccant chamber formed by the material under test (the dish opening diameter squared x 0.785).

## 7. REPORT

7.1 Immediately following each test the report (official record) of the facts pertinent to the test shall be completed, and shall include the following:

7.1.1 A statement that the test was conducted in compliance with this procedure, or a description of the deviations from this procedure. Report all options selected and details of otherwise specified procedure that were followed as permitted in 3.4, 3.5, 4.1.1, 5.1, and 6.3.

7.1.2 Identification of the specimen and the specific material tested.

7.1.3 Results of the test. State the rate of water penetration in grams per 100 square inches per 24 hours and the period and temperature of immersion.

7.1.4 When the test is performed to check compliance with requirements, state that the specimen did or did not meet the requirements and give the source for the requirements.

7.1.5 When the test is conducted to evaluate or compare products or methods, the report shall include a statement of any observations that may lead to improvements. Report extent of any degradation, or adhesive transfer from the test material.

## 8. NOTES

8.1 Results are affected by the time required for water or water vapor to penetrate from the outside to the inside of the test material, and by the rate at which water or water vapor moves through the material after penetration occurs. These may not be the same and no differentiation is made in this test procedure. To measure the rate of penetration of pressure-sensitive tapes use Fed Std Test Method 101/3032.



## WATER RESISTANCE OF MARKINGS

### 1. SCOPE

1.1 This method is appropriate for determining whether or not the markings on a package or packaging material appear adversely affected by exposure to water.

### 2. DEFINITIONS

2.1 Not applicable.

### 3. APPARATUS

3.1 Chemically pure water with a pH between 5.5 and 8.0.

3.2 A pan, tub, or other vessel of convenient size fitted with a means of circulating water and with racks or clips to hold the specimens submerged in the water. The holding device shall insure sufficient space between specimens so all markings will be exposed to the circulating water. Water shall be circulated across the markings at a velocity of about 1 foot per second.

### 4. SPECIMENS

4.1 The specimen shall be one complete set of identification markings applied using the surface, marking material, and method proposed for the specific application in packaging. The dimensions of the specimen shall be whatever are convenient, but not less than required for the set of markings prescribed.

### 5. CONDITIONING

5.1 The specimen shall be permitted to dry under ambient room conditions for not less than 1 hour after applying the marking.

### 6. PROCEDURE

6.1 Submerge the specimen in circulating water at ambient room temperature for not less than 2 hours. Remove the specimen and blot off the excess water. While still wet, examine the markings for clarity, legibility, and tendency to smear when lightly rubbed with one finger. Record any evidence of adverse effects of water on the markings.

6.2 Allow the specimen to dry at room temperature and then examine again, and record any evidence of adverse effects of water on the markings.

7. REPORT

7.1 Immediately following each test the report (official record) of the facts pertinent to the test shall be completed, and shall include the following:

7.1.1 A statement that the test was conducted in compliance with this procedure, or a description of the deviations from this procedure.

7.1.2 Identification of the specimen and the specific material tested.

7.1.3 Results of the test. State whether or not the markings appeared adversely affected by exposure to water.

7.1.4 When the test is performed to check compliance with requirements, state that the specimen did or did not meet the requirements and give the source for the requirements.

7.1.5 When the test is conducted to evaluate or compare products or methods, the report shall include a statement of any observations that may lead to improvements.

8. NOTES

8.1 Not applicable.

WATER RESISTANCE OF PACKAGING MATERIALS  
(PLY SEPARATION)

1. SCOPE

1.1 This method is appropriate for determining whether or not a packaging material appears adversely affected by exposure to water or water vapor. It provides seven different procedures applicable to materials such as plywood, paper-overlaid veneer, box-board, paper, laminated barrier material, and similar products.

1.2 These procedures do not determine water penetration, transmission, leakage, or the extent to which any specific property is affected by exposure to water other than the resistance of the material to ply separation and delamination (see Notes).

2. DEFINITIONS

2.1 Water resistance is defined as the ability to withstand exposure to water or water vapor without adverse effects.

3. APPARATUS

3.1 A pan, tub, or other vessel of convenient size fitted with racks or clips is required to hold the specimens during the exposure to water. The holding arrangement shall not prevent delamination or deterioration of the specimen. The vessel shall be capable of maintaining the specified conditions of exposure to water.

3.2 Laboratory tap water with a pH between 5.5 and 8.0 shall be used.

3.3 When specified, a drying oven or chamber capable of maintaining the specified drying conditions will be required.

3.4 To determine the extent of delamination, a ruler graduated to 1/32 inch or less, and a feeler gage 0.003 inch thick, about 3/8 inch wide and 2 inches long are needed.

3.5 When specified, a tensile testing machine capable of load application at rates of 600 to 1,000 pounds per minute and a capacity of 100 to 500 pounds will be required.

3.6 When specified, a vacuum-pressure chamber (see figure 1) capable of withstanding a vacuum of 25 inches of mercury and a pressure of 60 to 70 p.s.i. will be needed.

4. SPECIMENS

4.1 Specimens of panel, sheet, film, board, or similar materials shall be taken at random in sufficient number to adequately represent the variation within the material. When the number and size are not otherwise specified, not less than four specimens shall be tested and the size shall be as indicated in Table I or not less than 6 by 6 inches.

5. CONDITIONING

5.1 Unless otherwise specified, no special conditioning of the specimens is required.

6. PROCEDURE

6.1 Before exposure, examine each specimen and record any abnormal features of the specimen.

6.2 Expose the specimen to water or water vapor as specified or as indicated in Table I. After each test, or if applicable, after each cycle of a test, visually examine the specimen for delamination and any other defects resulting from the exposure. Record evidence of delamination and any other type of failure. If applicable, measure and record the extent of each area of delamination in terms of length measured along the edge of the specimen and maximum width measured by determining the distance a feeler gage can be pushed gently into the delamination. In addition, for specimens exposed according to 6.2.4 or 6.2.5 record the tensile load required to cause failure of each specimen and the percentage of the area of failure attributable to either wood or glue failure.

6.2.1 Procedure A. The specimen shall be submerged in fresh tap water maintained at a temperature of 68° to 85°F. It shall be supported on edge in a fixture in a manner allowing unrestricted movement of water around the specimen and unrestricted opportunity for the specimen to delaminate. The specimen shall be submerged so its upper edge is 1 inch below the water surface. In lieu of a specified immersion period, the immersion period shall be as indicated in Table I. After immersion, remove the specimens from the water, shake gently to remove droplets and blot with absorbent paper or towels to remove free water from the surface. Using thumb pressure sufficient only to overcome the surface tension of the water, flex the edges of the specimen. For the purpose of this test, glue failure only (rather than fiber failure adjacent to the glue line) should be considered. For referee purposes, a soaked specimen shall be laid on a table in 73° ± 5°F and 50 percent RH conditions, with air from an electric fan blowing across the top surface of the specimen until the specimen fails or reaches equilibrium.



TABLE I. Recommended exposure procedures to determine ply-separation qualities of some laminated materials

Material	Suggested exposure	Suggested specimen size	Notes
Fiberboard:		Inches	
Weather resistant	6.2.1	6 by 10	Immerse specimen 24 hours. Corrugated fiberboard shall have the corrugated openings along the 10-inch edges. The top 10-inch edge shall be horizontal and 1 inch below the water surface.
Multiwall paper sacks	6.2.1	8 by 8	Immerse specimen 6 hours.
Flexible barrier materials	6.2.6	6 by 8	Immerse specimen 48 hours.
Chipboard, paperboard	6.2.7	6 by 6	Expose specimen 72 hours.
Paper-overlaid veneer:			
Domestic	6.2.2	6 by 6	Three-cycle exposure.
Weather resistant	6.2.2	6 by 6	Ten-cycle exposure.
Plywood:			
Low moisture resistant	6.2.2 or 6.2.3	2 by 5	Two-cycle exposure.
High moisture resistant	6.2.2 or 6.2.3	2 by 5	Fifteen-cycle exposure.
Weatherproof	6.2.4 or 6.2.5	3-1/4 by 1	After exposure, specimen shall be stressed to failure.

6.2.2 Procedure B. The specimen shall be submerged in fresh tap water maintained at a temperature of  $68^{\circ}$  to  $85^{\circ}\text{F}$ . It shall be supported on edge in a fixture in a manner allowing unrestricted movement of water around the specimen and unrestricted opportunity for the specimen to delaminate. The specimen shall be submerged so its upper edge is 1 inch below the water surface. After 4 hours' submersion, the specimen shall be dried for 20 hours in an environment where the relative humidity is a maximum of 60 percent and the temperature is  $68^{\circ}$  to  $85^{\circ}\text{F}$ . The air movement across both surfaces of the specimen shall be maintained at a velocity of approximately 1 foot per second. Repeat the preceding soaking and drying cycle until failure (delamination) occurs or until completion of the specified number of cycles. In lieu of a specified number of cycles, the number of cycles shall be as indicated in Table I.

6.2.3 Procedure C. The specimen shall be placed in a vacuum chamber (figure 1) and submerged in water initially at  $100^{\circ} + 10^{\circ}\text{F}$ . A vacuum of 15 inches of mercury shall be drawn, maintained for 30 minutes, and then released. For 4-1/2 additional hours the specimen shall be soaked in the same water at atmospheric pressure. During the 30 minutes the specimen is exposed to the vacuum and during the 4-1/2 hour soaking period, control of the water temperature is unnecessary. After soaking, the specimen shall be dried for 15 hours in a drying oven maintained at  $150^{\circ} + 5^{\circ}\text{F}$ . While in the oven, unrestricted circulation of air around the specimen shall be provided.

6.2.4 Procedure D. A test specimen (figure 2) shall be submerged in boiling water for 4 hours, dried in an oven maintained at  $150^{\circ} + 5^{\circ}\text{F}$  for 20 hours, and then resubmerged in boiling water for 4 hours. While still wet, the ends of the specimen shall be gripped as shown in figure 3 or using other suitable grips that will cause failure mainly in shear and subjected to increasing tensile load until it fails. The load shall be applied at a rate of 600 to 1,000 pounds per minute.

6.2.5 Procedure E. A specimen (figure 2) shall be placed in a vacuum-pressure chamber (figure 1) and submerged in fresh, cool tap water. A vacuum of 25 inches of mercury shall be drawn, maintained for 30 minutes, and then released. Then, with the specimen still in the chamber, water pressure of 60 to 70 pounds per square inch shall be applied and maintained for 30 minutes. After removal and while still wet, the specimen shall be stressed to failure according to 6.2.4.

6.2.6 Procedure F. The specimen shall be immersed in fresh tap water maintained at a temperature of  $68^{\circ}$  to  $86^{\circ}\text{F}$  for a specified time period. In lieu of a specified time period, the specimen shall be immersed 48 hours, as indicated in Table I. While submerged, the specimen

shall be supported in a manner allowing unrestricted circulation of water around the specimen and an unrestricted opportunity for the specimen to delaminate. Then, for 24 hours, the specimen shall be exposed in a oven maintained at  $160^{\circ} \pm 2^{\circ}\text{F}$ . While in the oven, unrestricted air circulation around the specimen shall be provided. Prior to examining, the specimen shall be cooled to approximately  $70^{\circ}\text{F}$ .

6.2.7 Procedure G. The specimen shall be exposed in a atmosphere maintained at  $100^{\circ} \pm 5^{\circ}\text{F}$  and 90 percent relative humidity for a specified time period. In lieu of a specified time period, the specimen shall be exposed 72 hours, as indicated in Table I. It shall be supported in a manner allowing unrestricted circulation of the exposure atmosphere and unrestricted opportunity to delaminate. After exposure, the edges of areas bonded with adhesive shall be flexed with thumb pressure. For the purpose of this test, only glue failure (rather than fiber failure) shall be considered.

## 7. REPORT

7.1 Immediately following each test, the report (official record) of the facts pertinent to the test shall be completed, and shall include the following:

7.1.1 State that the test was conducted in compliance with this method, or give a description of the deviations from this method. Report all options selected and details of otherwise specified procedures that were followed, as permitted in 3.6, 4.1, 5.1, and 6.2 thru 6.2.7.

7.1.2 Identify the specimen and the specific material tested.

7.1.3 Give results of the test. Report the extent of delamination and any other evidence of failure if any occurred, or give evidence that demonstrated failure did not occur.

7.1.4 When the test is performed to check compliance with requirements, state that the specimen did or did not meet the requirements, and give the source for the requirements.

7.1.5 When the test is conducted to evaluate or compare products or methods, include in the report any observations that may lead to improvements.

## 8. NOTES

8.1 The ability of a material to withstand exposure to water or water vapor without adverse effects on the material cannot be completely evaluated by the simple methods of examination described in this test procedure. To determine the extent to which exposure to water affects a specific property, the property must be measured before and after exposure

METHOD 3028  
March 13, 1980

to water. Such test methods are identified in Fed. Test Method Std No. 101C by the property measured. Also, if the ability of a material to resist penetration by water is desired, it should be measured by the appropriate method given in Fed. Test Method Std. No. 101C for measuring water penetration or transmission characteristics of a material.

8.2 The qualification, "unless otherwise specified," appears in the paragraph regarding:

Apparatus (3.3, 3.5, 3.6).  
Specimen (4.1).  
Conditioning (5.1).  
Exposure (6.2, 6.2.1, 6.2.2, 6.2.6, and 6.2.7).

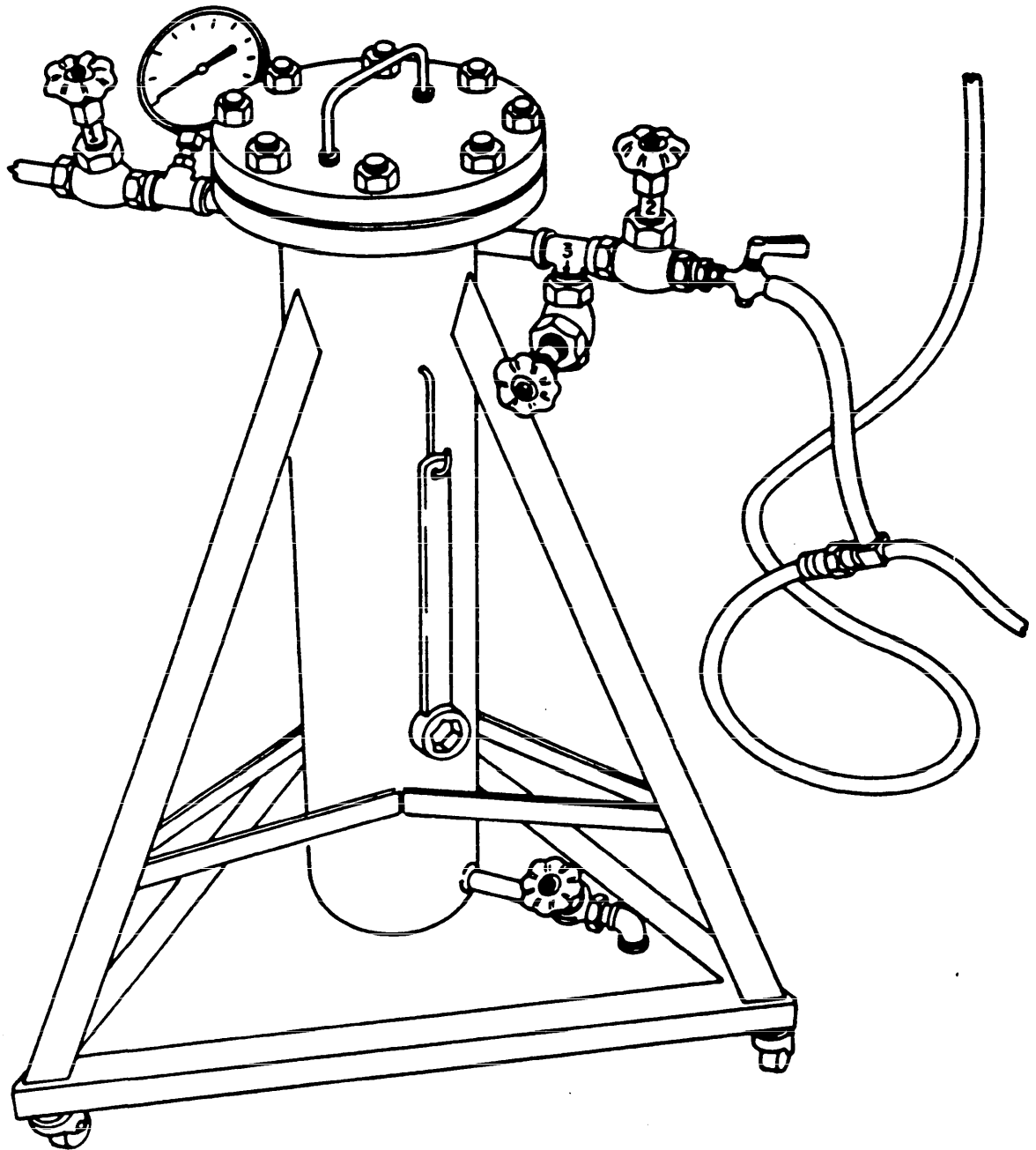
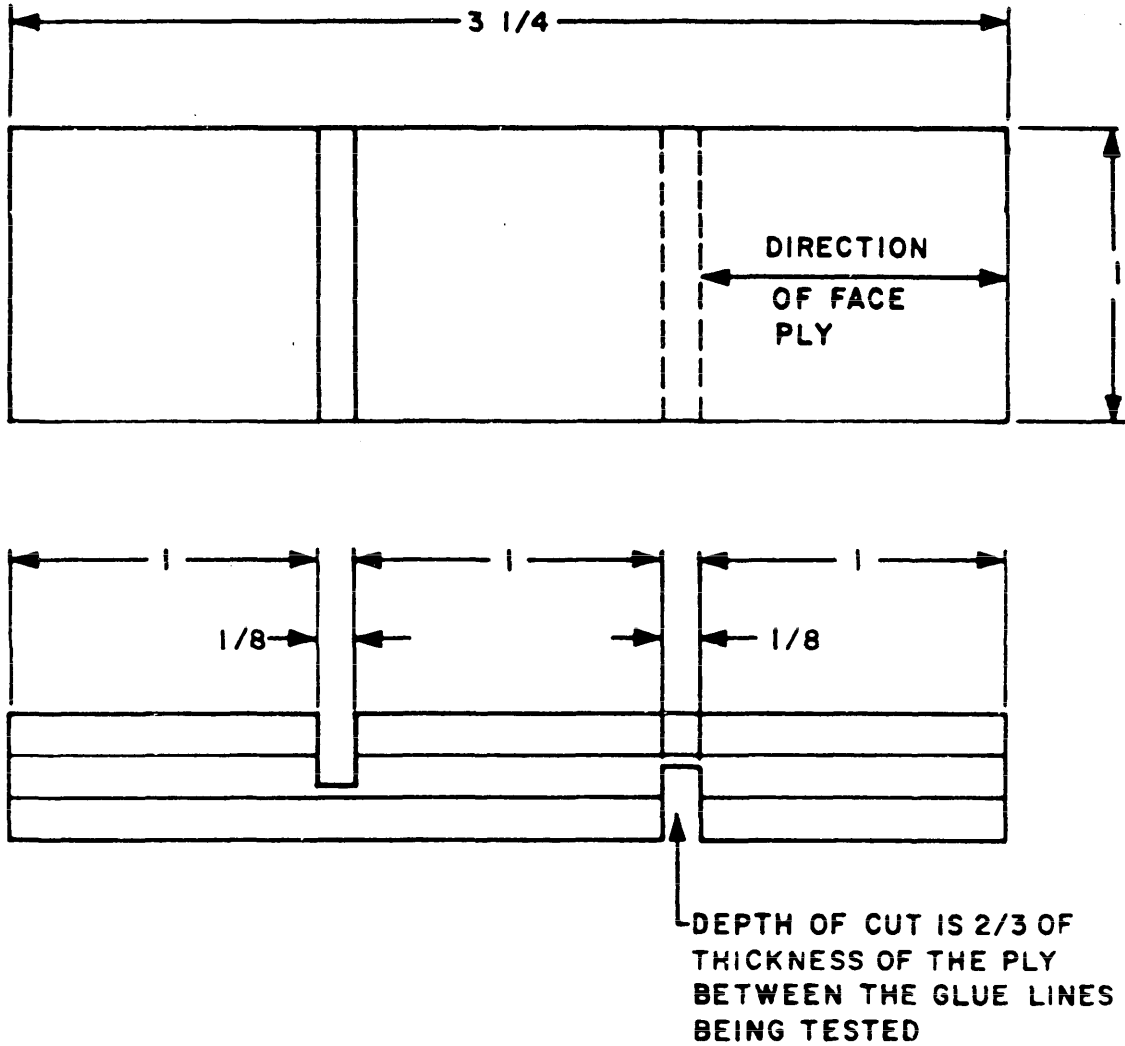

Figure 1. Vacuum pressure chamber.



DIMENSIONS IN INCHES.

Figure 2. Plywood delamination specimen.

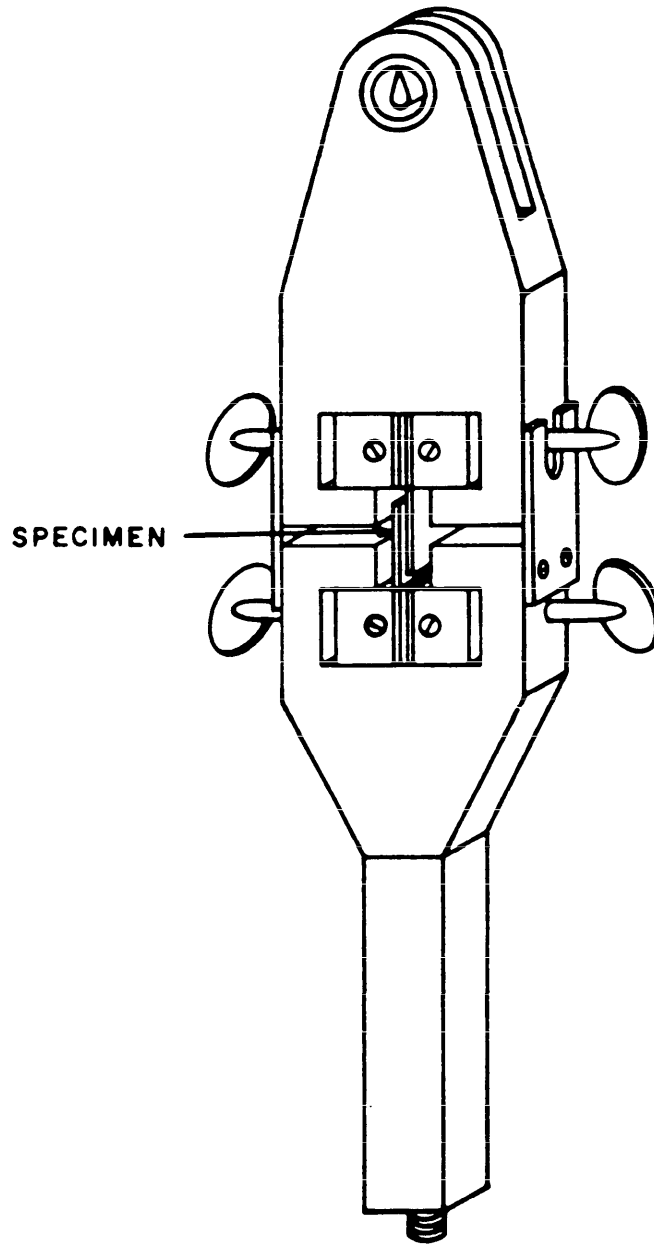

Figure 3. Jaws for shear test.





WATER VAPOR PERMEABILITY TEST OF PACKAGING MATERIALS  
(WATER VAPOR TRANSMISSION RATE TEST)

PROCEDURE A

1. SCOPE

1.1 This method provides two procedures for determining the water vapor permeability of materials. The method is applicable to sheet materials including paper, plastic or metallic films, sealing tapes, and coated, impregnated, or laminated materials. It provides for a range of conditions of temperature and relative humidity to simulate the atmospheric conditions which the materials might encounter in service. For determining the water vapor permeability of pressure-sensitive tape, use Fed Std Test Method 101/3033.

1.2 Procedure A involves sealing a membrane of the test material over a dish containing desiccant, and is designed for sheet materials in general, including heat-sealable material and sealing tapes, all tested in sheet form.

1.3 Procedure A(1) involves the fabrication of pouches and is designed specifically for relatively impervious heat-sealable materials that can be tested in the form of pouches.

1.4 The procedures may be applied to the material either as received or after creasing, flexing, aging, or other conditioning.

2. DEFINITION

2.1 Water vapor permeability (that is, water vapor transmission rate, WVTR) is defined for this method as the weight of water vapor transmitted through a given area of the test material in a given time when the test material is maintained at a constant temperature, and when one surface is exposed to very low relative humidity (that is, over a desiccant) and the other surface to a high relative humidity.

3. APPARATUS

3.1 The general apparatus shall consist of:

3.1.1 A test chamber or chambers capable of maintaining the environment at which the product is to be tested. (See 6.1.) The test chamber shall be provided with a suitable means for supporting each test assembly so as to afford free access of the conditioned air to the exterior surfaces of all specimens. For Procedure A, if possible, the test assembly should be weighed without removing it from the test environment.

3.1.2 Anhydrous calcium chloride, for use as a desiccant, in the form of small lumps that will pass a No. 8 (2,380 micron) sieve, but free of fines that will pass a No. 30 (590 micron) sieve. (Caution: Unused, fresh anhydrous calcium chloride must be provided.)

3.1.3 An analytical balance. For weighings outside the test atmosphere, an automatic balance is preferred.

3.2 For Procedure A, special apparatus shall include:

3.2.1 Open-mouth dishes of such size or shape that they can be readily accommodated on the pan of an analytical balance. The dishes shall be constructed of a corrosion-resistant impermeable material and as light as is consistent with the necessary rigidity. The area of the opening shall be as large as practicable; an area of at least 50 square centimeters is preferred. (This is equivalent to a circle about 3 inches in diameter.) The test dishes shall be of a design that the specimens can be sealed over the opening of the dishes in such a manner that their exposed area is well defined and the same on both sides, and that no leakage of water vapor can occur at or through the edges of the specimens. The exposed area of the specimens shall be not greater than the area of the desiccant in the test dish. There shall be no obstructions within the dish that would restrict the flow of water vapors between the specimen area and the desiccant in the dish. For examples of suitable dishes and methods of sealing the specimen to the test dishes, see ASTM E 96-66(1972).

3.2.2 A wax for use in sealing the specimen to the test dish which will cling tenaciously to both surfaces. It must not be brittle, must not check, crack, soften, or absorb moisture at the exposure conditions, and must be free of impurities of such size which would be retained on a 40-mesh screen. A mixture of 60 percent amorphous wax and 40 percent refined crystalline paraffin wax is suitable for exposures at room temperature or higher. Suitable amorphous waxes for mixing with the paraffin are grades Nos. 2300, 2305, and 2310 of the Socony Vacuum Oil Company, or equal. A satisfactory wax for exposures at low temperatures is Quaker State Cream Amo wax, melting point 130°F. obtainable from the Quaker State Oil Refining Corporation, Oil City, Pa., or equal.

3.3 For Procedure A(1), special apparatus shall include:

3.3.1 A heat sealer equipped with controls for temperature, dwell time, and pressure.

3.3.2 Porous heat-sealable tea bag stock for use in making bags for desiccant. A 14-pound Aldrite HS 24 manufactured by the Aldine Paper Company, Inc., 373-5 Fourth Avenue, New York, N.Y., or equal is appropriate.

#### 4. SPECIMENS

4.1 Unless otherwise specified, samples shall be taken at random in sufficient number to adequately represent the variation within the product. When the number and size of specimens are not otherwise specified, the specimens for each procedure shall consist of:

4.1.1 For each Procedure A, each specimen shall consist of a small sheet of the product under test. Dimensions shall be appropriate for the special apparatus provided under 3.2. At least three specimens shall be prepared for each test environment. However, if the two surfaces of a product are dissimilar, at least six specimens shall be prepared, three for testing with one surface exposed and three for testing with the other surface exposed to the test environment.

4.1.2 For Procedure A(1), each specimen shall consist of an 8-by 12-inch sheet of the product under test. At least four specimens, two with the length parallel to the machine direction and two with length perpendicular to the machine direction of the material, shall be prepared for each test environment.

#### 5. CONDITIONING

5.1 Unless otherwise specified, the specimens need not be conditioned prior to assembly to the test dishes or fabrication into pouches.

#### 6. PROCEDURE

6.1 Unless otherwise specified, the test environment shall be one or more of the following combinations of relative humidity and temperature, depending upon the end use of the material (see 1.3):

- (1)  $100^{\circ} \pm 2^{\circ}\text{F.}$ , 90 to 95 percent relative humidity.
- (2)  $73^{\circ} \pm 2^{\circ}\text{F.}$ ,  $50 \pm 2$  percent relative humidity.
- (3)  $40^{\circ} \pm 2^{\circ}\text{F.}$ ,  $80 \pm 2$  percent relative humidity.
- (4)  $0^{\circ} \pm 2^{\circ}\text{F.}$ ,  $95 \pm 2$  percent relative humidity.

#### 6.2 Procedure A (Sheet materials).

6.2.1 Place the desiccant uniformly distributed in the dish, allowing at least 2 millimeters of airspace between the desiccant and the test specimen. Seal the specimen to the opening of the dish in such a manner that leakage of water vapor at or through the edges will not occur. (For suitable methods of sealing, see ASTM E 96-66(1972).)

6.2.2 Weigh the assembly on the analytical balance, and then place the assembly upright in the test chamber in such a manner that the test material will have free access to the exposure environment.

6.2.3 Make successive weighings of the assembly at suitable intervals, depending upon the permeability of the material, and plot the weight change against time. All weighings shall preferably be made without removing the test assembly from the test chamber. In instances where this is not possible, the test assembly shall be removed (one at a time), weighed immediately, and then returned to the test chamber. If the weight will not remain constant during the weighing operation, after removal from the test chamber the specimen shall be placed in a suitable nonhygroscopic container that will maintain the test environment around the specimen during weighing. Continue the test until a constant rate of gain in weight is attained, as indicated by three successive plotted points in a straight line.

6.3 Procedure A(1) (pouches).

6.3.1 Fold the test specimen in half to 6 by 8 inches and form a pouch by making a continuous seal along the two 6-inch ends and one 8-inch side with the heat sealer, using a suitable temperature, dwell time, and pressure previously determined for the material. The seal shall be located a distance from each edge of the pouch such that the inside width of the pouch is  $5\frac{5}{16} \pm 1/16$  inches.

6.3.2 Form a bag to hold the desiccant by cutting a 3-1/2-inch wide by 10-1/2-inch long piece from the web of tea bag stock, fold in half to 3-1/2 by 5-1/4 inches, and form the bag by making a seal not more than 1/4 inch wide along the two sides and the folded edge with the heat sealer. Two such desiccant bags will be required for each test specimen.

6.3.3 Fill the desiccant bag with not less than 50 cubic centimeters of the desiccant, and make a closure seal not more than 3/8 inch wide.

6.3.4 Insert the desiccant bag into the test specimen pouch and make a closure seal with its inner edge not more than 3/8 inch from the edge so closed.

6.3.5 Place the test pouch in the exposure environment for the stabilization period designated in Table I.

TABLE I.

Exposure environment		Stabilization period for test pouch	Exposure period between weighings
Temperature, °F.	Relative humidity, percent		
Procedure A			
100 ± 2	90 to 95	24 to 72 hours <sup>1</sup>	24 hours <sup>2</sup>
73 ± 2	50 ± 2	24 to 72 hours <sup>1</sup>	24 hours <sup>2</sup>
40 ± 2	80 ± 2	7 days	3 to 4 days <sup>2</sup>
0 ± 2	95 ± 2	10 to 14 days	14 days <sup>2</sup>
Procedure A(1)			
100 ± 2	90 ± 2	16 hours	64 to 68 hours

6.3.6 After the stabilization period given in Table I, unless otherwise specified, remove the pouch from the chamber. Promptly open the pouch by accurately cutting off a 1/2-inch strip across one end, and remove the desiccant bag. Insert a weighed fresh desiccant bag containing anhydrous desiccant into the pouch and reseal the pouch as in 6.3.4. Immediately place the pouch in the chamber maintaining the exposure environment and observe the time, which is the start of the period of exposure. At the end of the period of exposure given in Table I, unless otherwise specified, the bag containing the desiccant shall be removed from the pouch and weighed immediately. (To avoid the possibility of moisture change while being weighed, the bag of desiccant should be weighed each time in an impervious container of known tare weight.)

<sup>1</sup> The short period (24 hours) for thin, single-ply materials and longer periods for materials of several plies laminated together.

<sup>2</sup> If a straight-line relationship is not established with this exposure period, test the specimen for leaks; and if leaks are found, repeat the test using a more carefully prepared specimen. If no leaks are found, repeat the test using a new specimen and a shorter exposure period between weighings.

6.3.6.1 For pouches of nonhygroscopic materials which will remain constant in weight during weighing, the following alternate simplified procedure may be used: After the stabilization period, immediately weigh the sealed pouch and promptly begin the exposure period. At the end of the period of exposure, again weigh the sealed pouch. The exposure period may be interrupted briefly (not more than 2 minutes) for interim weighings of the sealed pouch at 8-hour, or longer, intervals of exposure (see 8.2).

6.3.7 Record the observed weights and the times of weighings; also the times and dates at the start and the end of the conditioning period and the exposure period. After the test, flatten the pouch and measure along centerlines and record the inside length and width of the pouch.

## 7. REPORT

7.1 Following the completion of the test, a report shall be written which shall include:

7.1.1 A statement that the test was conducted in compliance with this procedure or a description of the deviation from it. Report all options selected and otherwise specified details that were followed, as permitted in paragraphs 4.1, 5.1, 6.1 and 6.3.6.

7.1.2 A description of the material tested including the average, minimum, and maximum thickness of the sheet on which the test was performed. Refer to any preceding tests or treatment of the specimens.

7.1.3 The temperature and relative humidity of the test environment and the time intervals between weighings used to establish the water vapor transmission rate.

7.1.4 The average water vapor transmission rate (to two significant figures) expressed as g. per square meter per 24 hours and calculated as follows:

$$WVTR = \frac{g \cdot 24}{a \cdot t}$$

where:

- g = weight gain or loss in grams,
- a = exposed area of specimen in square meters; for pouches, consider only the area between the inner edges of the seals,
- t = time, in hours, during which gain or loss in grams was observed. Two water vapor transmission rates shall be reported for samples having dissimilar materials on each side, designating the side exposed to the test environment.

To convert WVTR from grams per square meter per 24 hours to grams per 100 square inches per 24 hours, multiply by 0.0645.

8. NOTES

8.1 This method is designed primarily for relatively impervious materials, and the procedures are based upon establishing a definite constant relative humidity within the desiccant space. This situation will exist if the moisture is absorbed by the desiccant as fast as the moisture moves through the test material. When, during the period of exposure, successive interim weighings reveal a decreasing rate of weight gain, the constant relative humidity within the desiccant space probably is not being maintained; and data obtained under such conditions shall not be used to establish WVTR. When this occurs even with a shortened exposure period, the test report shall so state and the method assumed not applicable to the particular material.

8.2 Three methods for obtaining constant relative humidities by means of aqueous solutions are described in ASTM E 104-51.

METHOD 3030.1  
March 13, 1980

PROCEDURE B

ASTM E-96 - WATER VAPOR TRANSMISSION OF MATERIALS IN SHEET FORM

1. SCOPE

1.1 When specified in the commodity specification, contract or order, Procedure B may be used in lieu of Procedures A and A(1) except that levels of intensities shall be those specified in Procedure A and A(1).



## CLEANLINESS

### 1. SCOPE

1.1 This method is intended to indicate whether or not an item is clean by checking for evidence of contamination. Four techniques - (a) visual examination, (b) wiping, (c) checking for acidity or alkalinity, and (d) water break - are described; and one or more may be appropriate for a specific item. If no evidence of contamination is found, the results indicate but do not alone confirm that the specimen is clean.

1.2 This procedure does not apply to items processed in accordance with clean room requirements.

### 2. DEFINITIONS

2.1 Not applicable.

### 3. APPARATUS

3.1 Visual examination. A light source consisting of a fluorescent lamp, using a day-light tube of a minimum length of 18 inches and a minimum of 30 watts. The inside surface of the reflector shall be finished in white and have a high coefficient of reflection. The lamp shall be equipped with a ball and socket joint so that the light can be directed at any angle.

3.2 Wipe test.

3.2.1 Two lint-free clean cloth at least 12 inches square, one white and one dark colored.

3.2.2 The light source described in 3.1.

3.3 Check for acidity and alkalinity.

3.3.1 pH indicating papers and a supply of distilled water.

3.3.2 The light source described in 3.1.

3.4 Water break test. Apparatus consists of a supply of distilled water and a container for water to drain into.

### 4. SPECIMENS

4.1 The specimen shall be one cleaned item ready for packaging and preservation unless otherwise specified.

5.           **CONDITIONING**

5.1           Not applicable.

6.           **PROCEDURE**

6.1           **Visual examination.**

6.1.1        Carefully examine all surfaces, depressions, inside corners, and crevices on the specimen for dirt, corrosion, oil, grease, or similar foreign residues. While looking for foreign matter, use various angles of incident light. Record whether or not foreign matter was observed on the specimen.

6.2           **Wipe test.**

6.2.1        Wipe a portion or portions of the specimen with a clean, lint-free, white cloth, and examine the cloth for any foreign matter.

6.2.2        Wipe another portion or other portions of the specimen with a clean, lint-free, dark-colored cloth, and examine the cloth for any foreign matter.

6.2.3        Record that foreign matter either was or was not collected on the cloths.

6.3           **Check for alkalies and acids.**

6.3.1        Allow the specimen to dry after the final rinse, wet the specimen with a few drops of distilled water, and then wet the appropriate indicating paper with this liquid. Methyl red paper may be used to test for the lower pH limit; red litmus paper may be used to test for the upper pH limit; or universal pH indicating papers, such as those covered by O-P-94, may be used for both limits. Observe and record any change in the color of the papers. A red tint on the methyl red paper indicates too much acidity, and a blue tint on the litmus paper indicates too much alkalinity. For universal indicating paper, colors recording a pH below 6.4 or above 8.3 indicate excessive acidity or alkalinity, respectively. Record any evidence of excessive acidity or alkalinity.

6.4           **Water break test.**

6.4.1        The item shall be dipped in distilled water and allowed to drain. The water must flow evenly off the specimen without the film breaking. Formation of small droplets or breaking of the film indicates the presence of foreign matter. Record whether or not foreign matter

was detected by the test. For small items the distilled water is poured onto the item, or preferably dispensed from a chemist's flexible wash bottle, or atomized onto the surface using any small atomizing device. A water break free surface is attained when the droplets of water spread into a continuous film of water and form a lens. If water gathers into droplets or if the film or water breaks suddenly, then the surface is not water break free.

7. REPORT

7.1 Immediately following each test, the report (official record) of the facts pertinent to the test, shall be completed and shall include the following:

7.1.1 A statement that the test was conducted in compliance with this procedure, or a description of the deviations from this procedure. Report all options selected and details of otherwise specified procedure that were followed as permitted in 1.1 and 6.

7.1.2 Identification of the specimen tested.

7.1.3 Results of the test. State either no evidence of contamination, or specimen not clean and give evidence of contamination, including any excessive acidity or alkalinity.

7.1.4 When the test is performed to check compliance with requirements, state that the specimen did or did not meet the requirements and give the source for the requirements.

7.1.5 When the test is conducted to evaluate or compare products or methods, the report shall include a statement of any observations that may lead to improvements.

8. NOTES

8.1 To insure cleanliness of critical items, a positive test such as a compatibility or corrosion test may be essential.



## CORROSION INHIBITING ABILITY OF V.C.I. VAPORS

### 1. SCOPE

1.1 This test method provides two procedures which may be used to determine the corrosion inhibiting effectiveness of the vapors of VCI (volatile corrosion inhibitors) materials. Procedure A is for testing VCI materials in crystalline or liquid form. Procedure B is for testing VCI-coated or VCI-treated materials. Determinations may be made in the "as received" condition or on specimens that have been exposed to conditions causing accelerated exhaustion.

### 2. DEFINITIONS

2.1 Corrosion. Deterioration of a material by chemical action, usually as a result of oxidation, electrochemical, acid or alkali action. In this test method a visible change in the surface finish such as pitting or etching or the formation of loose or granular particles shall constitute corrosion. Stain alone shall not be considered corrosion.

2.2 Stain. Color changes formed only on a surface without any evidence of rust, pitting, etching, or deterioration of the surface.

2.3 Test surface. A specially prepared surface of the material to be retained with the specimen in the test environment and subsequently examined for evidence of corrosion.

### 3. APPARATUS

3.1 General. Applicable for both Procedures A and B.

3.1.1 A slow-speed grinding and polishing wheel and a supply of 240 grit aluminum oxide or silicon carbide abrasive.

3.1.2 Tanks for cleaning, rinsing solvents and fingerprinting removal.

3.1.3 A ventilated drying oven with a temperature control or a bank or infrared lamps.

3.1.4 Desiccator with drying agent.

3.1.5 An exposure chamber with a temperature control and a system for controlling relative humidity, if required.

3.1.6 When necessary for exhausting VCI materials, a device to regulate air flow is required.

3.2 Special apparatus required for Procedure A tests. The apparatus shown in figures 1 through 3 is used for testing materials in crystalline or liquid form. The test assembly is illustrated in figure 1. To assemble the components shown in figure 1, the aluminum tube is forced through the upper rubber stopper until the bottom of the stopper is 2-1/4 inches from the top end of the tube. The insulating sleeve is placed over the bottom end of the aluminum tube and caused to slide over the tube until contact is made with the base of the rubber stopper. This unit is placed through the center hole in the jar lid, and the stopper is forced tightly into the hole. The second rubber stopper is forced onto the aluminum tube until contact is made between the insulating sleeve and the base of the stopper. Lens paper is used in forcing the steel specimen into the rubber stopper. A dispenser (atomizer), figure 2, is used to introduce some types of VCI materials into the test assembly (figure 1). The glass vial attached to the atomizer shall be large enough to contain 1.0 gram of VCI material. A small inert vessel, 1-1/2 inches in diameter by 1/4 inch high, is suitable for introducing other grades of VCI materials into the test assembly. When liquid VCI is used, a cylindrical glass vessel, approximately 1.75 inches I.D. by 1.625 inches high is required. The apparatus shown in figure 3 is used for exhausting VCI in crystalline or liquid form.

3.3 Special apparatus required for Procedure B tests. The apparatus shown in figures 4 and 5 is used for testing VCI-coated or treated materials. Except for the parallel slots in the jar lid which are required to suspend impregnated or treated carrier samples in the test assembly, the test assembly shown in figure 4 is similar to that shown in figure 1. Shown in figure 5 is apparatus to exhaust VCI-treated or impregnated materials prior to testing. Specially treated paper clips used to hold the specimens during the exhaustion procedure are required. The recommended treatment consists of dipping the clips in resin coating conforming to MIL-R-3043 and then allowing them to air dry for 30 minutes followed by a baking period of 30 minutes at  $325^{\circ} \pm 5^{\circ}\text{F}$ . Paper clips treated with enamel or wax coatings are also satisfactory.

3.4 Test surface.

3.4.1 Unless otherwise specified, in the reference to this test method, the test surface shall be prepared on a plug of low carbon steel, QQ-S-698, condition 5.

3.4.2 Test surface preparation. A cold finished round bar of the metal 5/8-inch diameter, 1/2 inch long, shall be flat bottom drilled in the center of one end to form each plug. The hole shall have a depth of 3/8 inch and a diameter of 3/8 inch. The undrilled end shall be surface ground. Prior to use, the surface ground face shall be polished with 240 grit silicon carbide or aluminum oxide abrasive. The abraded face shall then be hand polished with No. 400 aluminum oxide paper at 90° to the previously abraded marks to a surface roughness of 4 to 6 micro-inches (RMS) for the test surface. (The use of iron oxide abrasives, and any abrasive paper that leaves residues not removable by the following cleaning methods is prohibited. Some abrasive papers and cloths that are intended to be used dry or wet have been found to leave such residues.) The plug shall be wiped clean with surgical gauze and the test surface examined microscopically for signs of corrosion or other defects. Defective surfaces shall not be used. Each usable metal plug shall be scrubbed with a brush or gauze swab in a tank or container of hot mineral spirits conforming to grade 1 of TT-T-291. This shall be followed by successive immersions in hot mineral spirits, boiling 95 percent methanol, and boiling absolute methanol, allowed to dry in clean air or placed in a ventilated clean drying oven; and then stored in a desiccator until ready for use.

3.4.3 If the plugs are stored in the desiccator for a period of more than 24 hours, the surface preparation shall be repeated starting with the final aluminum oxide polishing.

#### CAUTION

During and after cleaning, the plugs shall be handled only with clean lint-free gloves, forceps, or other means to prevent contamination of the test surface.

#### 4. SPECIMENS

4.1 Unless otherwise specified, specimens shall be selected at random and in sufficient number or quantity to adequately represent the material to be evaluated. Cautions shall be taken as necessary to prevent contamination of specimens.

4.2 The glass vial (figure 2) containing approximately 1.0 gram of VCI material is attached to the atomizer. The latter is then used to spray  $0.05 \pm 0.005$  gram of VCI through one of the two holes in the lid of the quart jar (figure 1).

4.3 Specimens required for Procedure B. A specimen of VCI-treated sheet material shall be a strip 1 by 6 inches. At 1/4 inch from one end, the specimen shall be folded to form a tab. Two specimens are required for each test. To determine the vapor inhibition after exhaustion of VCI-treated sheet materials normally used in sealed bag form, a strip 2-1/2 by 8 inches is required. When the VCI-treated sheet materials normally are used as wraps (rather than bags), a strip 2 by 8 inches is required. A 1/8-inch-diameter hole shall be punched 1/8 inch from the top end on the center line of the specimen. After the exhaustion procedure is completed, the central portion of the strip shall be cut to form two 1- by 6-inch specimens.

5. CONDITIONING

5.1 The specimen shall be subjected either to no conditioning, in which case it shall be tested promptly after removal from its container, or when tests after exhaustion are required, to whichever is appropriate of the following:

CAUTION

VCI vapors should be vented into a hood or to the outside.

5.1.1 Exhaustion procedure used for conditioning VCI materials in crystalline form for Procedure A. The test assembly and components are illustrated in figure 3. The rubber stopper shall be fitted into the large center hole in the lid. The glass funnel shall be forced through the 1/4-inch hole in the rubber stopper until the large open end of the funnel is 6 inches from the inside of the jar lid. The small piece of glass tubing shall be forced through the rubber stopper also. The jar shall be closed tightly and the junction of the glass and lid sealed with tape. A glass vial containing approximately 1 gram of VCI shall be attached to the atomizer and sprayed into the quart jar through one of the holes in the lid until  $0.10 \pm 0.005$  gram, as determined by weight loss, is dispensed. The holes shall be covered with tape. Then the assembly shall be connected to the inlet and outlet tubing in order that air maintained at  $50 \pm 2$  percent relative humidity shall pass into the jar containing the VCI at a rate of 100 cubic centimeters per minute. Unless otherwise specified, the completely assembled units shall be placed in a forced draft oven maintained at  $100^{\circ} \pm 2^{\circ}\text{F}$  for 5 days. The jar containing the VCI shall be removed from the oven and allowed to cool to room temperature. The procedure to test the VCI material (6.1.1) shall be started immediately after the procedure to exhaust the VCI material has been completed.



5.1.1.1 Exhaustion procedure for liquid VCI. The test assembly and components are illustrated in figure 3. For liquid VCI, however, the large open end of the funnel shall be 5 inches from the inside of the jar lid, and the two small holes in the lid shall be sealed with tape. Except for (1) the method of introducing the VCI material and (2) the exposure of the completely assembled unit, the procedure for liquid VCI is the same as for VCI in crystalline form (5.1.1).

- (1) Pour 25cc of material into the appropriate small vessel (3.2) and set it inside the glass jar so it will be directly beneath the funnel.
- (2) Unless otherwise specified, maintain the complete assembly at  $75^{\circ} \pm 5^{\circ}\text{F}$  for 7 days.

5.1.2 Exhaustion procedure used for conditioning VCI-coated or VCI-treated materials.

5.1.2.1 Coated materials normally used in bag form. The assembly in which to perform exhaustion is illustrated in figure 5. Prepare a 2-1/2 by 8-inch pouch by sealing together the edges of the specimen material. The coated surface shall form the interior of the pouch. Place treated paper clips at each end of the pouch allowing 1/4 inch of the clips to extend beyond the longitudinal edges of the pouch for ease of handling. A 1/8-inch-diameter hole shall be punched outside the center of the seal, 1/8 inch from the top edge. The pouch shall be hung in a glass tube stoppered at both ends. The bottom of the tube shall contain a glass cylinder packed with glass wool wrapped in a surgical gauze. The assembled tube shall be connected to the inlet and outlet tubing in order that air maintained at  $50 \pm 2$  percent relative humidity shall pass over the pouch at a rate of 100 cubic centimeters per minute. Unless otherwise specified, the completely assembled unit shall be placed in a forced draft oven maintained at  $140^{\circ} \pm 2^{\circ}\text{F}$  for 12 days. The pouch shall be removed from the tube and cut into 1- by 6-inch test strips.

5.1.2.2 Coated materials normally used as wraps. The assembly in which to perform exhaustion is illustrated in figure 5. Place treated paper clips at each end of a 2- by 8-inch strip allowing 1/4 inch of the clips to extend beyond the longitudinal edges of the strip for ease of handling. A 1/8 inch diameter hole shall be punched in the center of the strip 1/8 inch from the top edge. Each strip shall be hung in a separate pyrex glass tube stoppered at both ends. The bottom of the glass tube shall contain a glass cylinder packed with glass wool wrapped in surgical gauze. The assembled tube shall be connected to the inlet and outlet tubing in order that air maintained at  $50 \pm 2$  percent relative humidity shall pass over the strip at a rate of 100 cubic centimeters per minute.

Unless otherwise specified, the assembled unit shall be placed in a forced draft oven maintained at  $140^{\circ} \pm 2^{\circ}\text{F}$  for 12 days. The strip shall be removed from the tube and cut into 1- by 6-inch test strips. Two 1- by 6-inch strips shall be used in the CIA test.

6. PROCEDURE

6.1 This test shall be run in triplicate, along with a control using a test surface and no vapor inhibitor.

6.1.1 Procedure A.

6.1.1.1 VCI material in crystalline or liquid form tested in the "as received" condition. Ten cubic centimeters of a synthetic glycerin-water solution having a specific gravity of 1.076 at  $75^{\circ} \pm 3^{\circ}\text{F}$  to effect an atmosphere of 90 percent relative humidity shall be introduced into the bottom of the test assembly. As specified, the VCI materials shall be introduced into the test assembly (figure 1) either with an atomizer or in a small vessel. When VCI material is introduced in the test assembly with an atomizer, a glass vial containing approximately 1 gram of material shall be attached to the atomizer and sprayed into the test assembly through one of the holes in the lid until  $0.05 \pm 0.005$  gram, as determined by weight loss, is dispensed. Then the holes in the lid shall be covered with tape having a low water vapor transmission rate. When the VCI material is introduced in the test assembly in a vessel,  $0.05 \pm 0.005$  gram shall be weighed, placed in the vessel, and the vessel placed on the bottom of the jar. The lid shall be placed on the jar, tightened, and the junction of the glass and lid sealed with tape.

6.1.1.2 VCI material in crystalline or liquid form tested in the "after exhaustion" condition. After exhausting (see 5.1.1), the lid containing the funnel shall be removed, 10 cubic centimeters of a synthetic glycerin-water solution having a specific gravity of 1.076 at  $75^{\circ} \pm 3^{\circ}\text{F}$  to effect an atmosphere of 90 percent relative humidity shall be introduced into the bottom of the quart jar, and immediately the lid containing the test surface (3.4) shall be placed on the test assembly.

6.1.1.3 Expose the test assembly for 20 hours at a temperature of  $75^{\circ} \pm 5^{\circ}\text{F}$ . Cold water at a temperature  $40^{\circ}\text{F}$  below the ambient shall be added to the aluminum tubes until full. After 3 hours, the water shall be removed from the tubes and the steel specimen evaluated for evidence of rust. If the blank specimen does not rust, the test shall be rerun.

6.1.2 Procedure B. Ten milliliters of synthetic glycerin-water solution having a specific gravity of 1.076 at  $75^{\circ} + 3^{\circ}\text{F}$  to effect an atmosphere of 90 percent relative humidity shall be introduced into the bottom of the test assembly (figure 4). Two specimens, each 1 by 6 inches, shall be placed through the parallel slots of the test assembly jar with the treated surfaces facing the steel specimen. To fasten the treated carrier in position, 1/4 inch of the specimen shall be bent onto the outer surface of the lid and this tab and the slot covered with tape having a low water vapor transmission rate. The lid shall be closed tightly and the junction of the glass and lid shall be sealed with tape. Expose the test assembly for 20 hours at  $75^{\circ} + 5^{\circ}\text{F}$ . Then, cold water at a temperature  $40^{\circ}\text{F}$  below the ambient shall be added to the aluminum tubes until full. After 3 hours, the water shall be removed from the tubes and the steel specimens shall be evaluated for any evidences of corrosion. If the blank specimen does not rust, the test shall be rerun.

## 7. REPORT

7.1 Immediately following each test the report (official record) of the facts pertinent to the test shall be completed, and shall include the following:

7.1.1 A statement that the test was conducted in compliance with Procedure A or B, or a description of the deviations from the technique of these procedures. Report all options selected and details of otherwise specified procedure that were followed. Indicate whether the material was tested "as received," after exhaustion, or both.

7.1.2 Identification of the specimen and the specific material tested. Also identify the test surface material.

7.1.3 Results of the test. State whether the specimen was or was not effective in preventing corrosion of the test surface material.

7.1.4 When the test is performed to check compliance with requirements, state that the specimen did or did not meet the requirements and give the source for the requirements.

7.1.5 When the test is conducted to evaluate or compare products or methods, the report shall include a statement of any observations that may lead to improvements.

## 8. NOTES

8.1 The exposure environment and duration given are such that unprotected steel will corrode, and are intended to determine whether or not the specimen is effective to prevent corrosion of the test

METHOD 4031  
March 13, 1980

surface of steel. For other materials, the test surface material, the environment, and the duration must all be considered in specifying the conditions necessary to determine whether or not a specimen will inhibit corrosion of the test surface.

8.2 Details are given with the qualification, "unless otherwise specified," in the paragraphs regarding:

Test surface (3.4.1).

Specimens (4.1).

Duration of test (5.1.2.1 and 5.1.2.2).

FED. TEST METHOD STD. NO. 101C

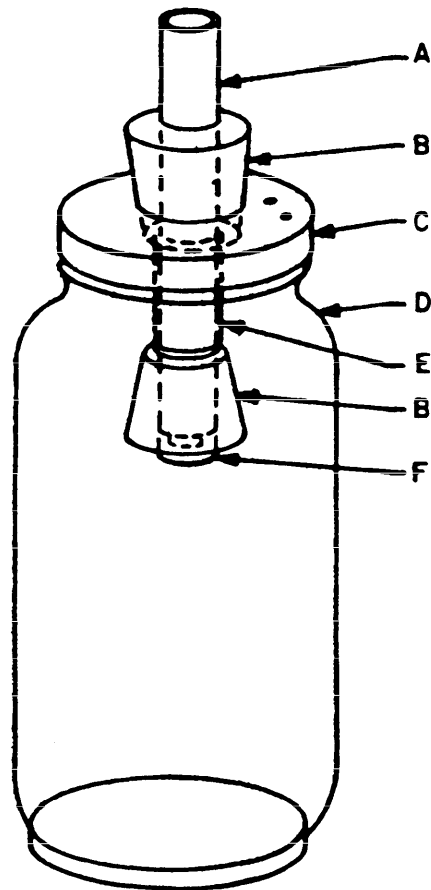

- A - Water retainer - Aluminum tube 4-1/2 in length, 5/8 OD and 1/2 ID. The tube shall have a capacity of 16 ml distilled water at 75° ± 3°F.
- B - Rubber stoppers - 2 #6-1/2 rubber stoppers with 1/2 hole bored through centers.
- C - Jar lids - Plastic screw type lid, holes 1-3/16 drilled through center with 2, 1/4 dia. holes 1 inch apart near the edge.
- D - Jars - Quart size, mouth size 2-3/8 dia., 7 inches in height, ID of 3-1/4.
- E - Insulating sleeve - 1/2 ID rubber tubing, length 1-1/2.
- F - Steel specimen - 5/8 OD, 1/2 long with 3/8 deep flat bottom hole drilled in center (1/8 wall cup)/

DIMENSIONS IN INCHES.

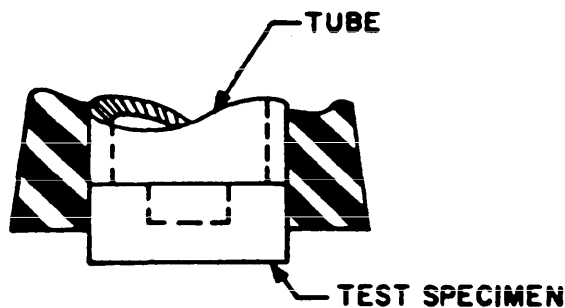

ENLARGED VIEW OF "F"

Figure 1. Test components.

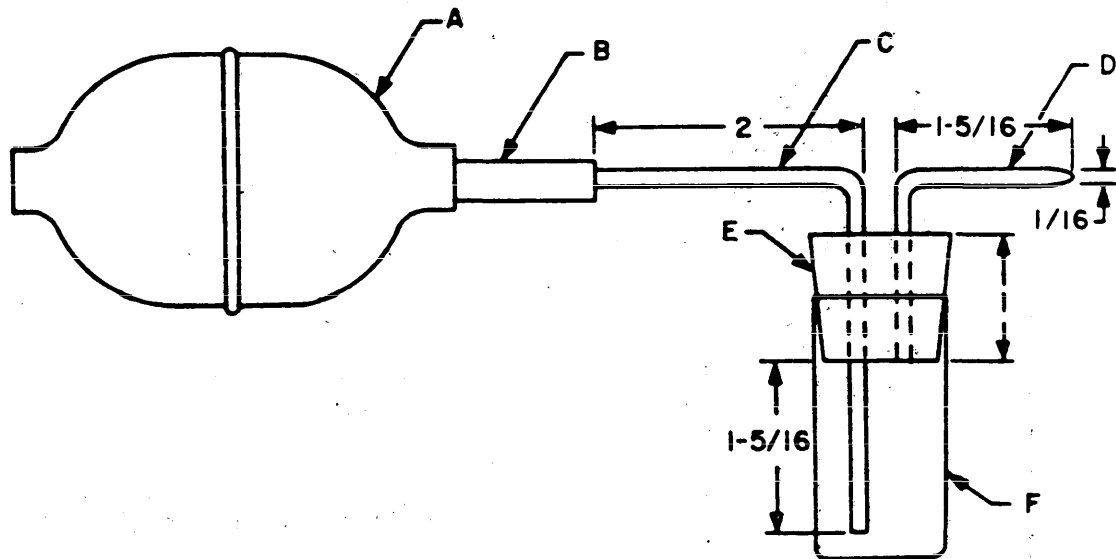

- A - Bulb - Davol Rubber Co., Providence, RI  
Bulb No. 1651S.
- B - Rubber tubing - 1 inch long.
- C - Pyrex glass tubing - 1/8 ID, length to suit.
- D - Pyrex glass tubing - 1/8 ID, length to suit.
- E - Rubber stopper - No. 4 with suitable holes  
to accommodate glass tubing.
- F - Glass vial - 2 by 7/8 ID.

DIMENSIONS IN INCHES.

Figure 2. Dispenser for introduction of volatile corrosion inhibitors into test assembly.

- A - Pyrex glass tubing - 1/8 ID, length to suit.
- B - Rubber stopper - No. 6 with two holes to suit insertions.
- C - Jar lid - plastic screw type, with hole 1-3/16 dia. drilled through center and two 1/4 dia. holes near periphery of lid.
- D - Quart glass jar - 2-3/8 mouth diameter, 7 inches deep.
- E - Pyrex glass funnel - approximately 2 ID at mouth, 8 inches long.
- F - Pyrex glass and rubber tubing - 1/4 ID and 7/16 OD.
- G - Rubber stopper - No. 12 with suitable 7/16 dia. holes.
- H - Quart glass jar - 2-3/8 mouth diameter, 7 deep, containing glycerine-water solution (Sp. Gr. 1.180) and maintaining the level of solution at 5 inches with the inlet tube immersed 4 inches in solution.
- J - Copper coil (OD 1/4, ID 5/32, length 10 ft.) - coil ID 4-3/8.

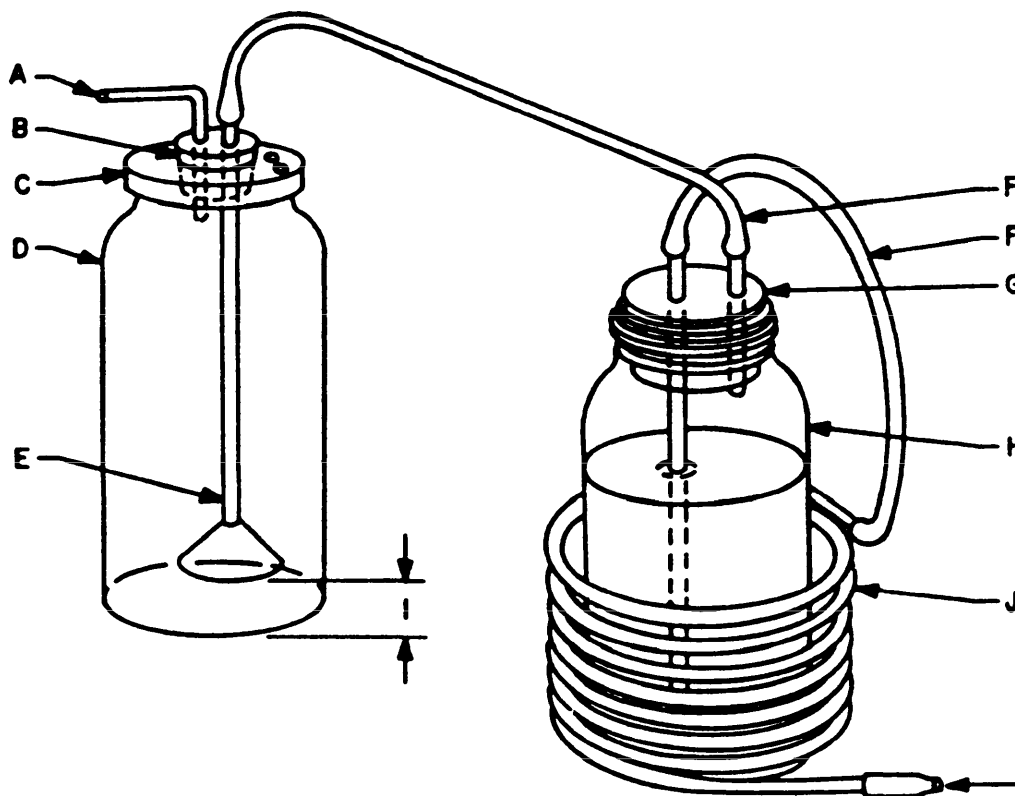

DIMENSIONS IN INCHES.

Figure 3. Apparatus for exhaustion of volatile corrosion inhibitors.

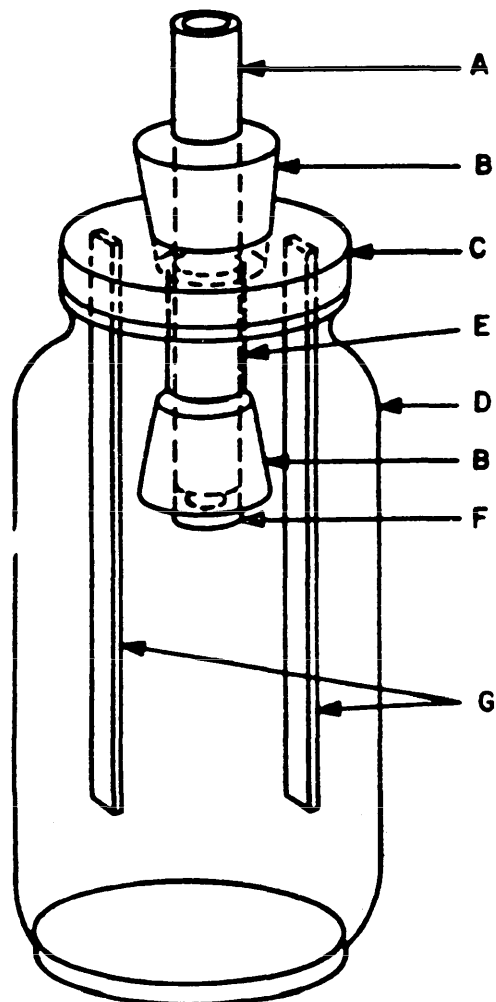

- A - Water retainer - Aluminum tube 4-1/2 in length, 5/8 OD and 1/2 ID. The tube shall have a capacity of 16 ml of distilled water at  $75^{\circ} \pm 3^{\circ}\text{F}$ .
- B - Rubber stoppers - 2 #6-1/2 rubber stoppers with 1/2 hole bored through centers.
- C - Jar lids - Plastic screw type lid, holes 1-3/16 drilled through center with parallel slits, 1/4 wide and 1-1/2 long formed 1/4 from the edge of the center hole.
- D - Jars - Quart size, mouth size 2-3/8 dia., 7 in height, ID of 3-1/4.
- E - Insulating sleeve - 1/2 ID rubber tubing, length 1-1/2.
- F - Test surface plug - 5/8 dia., 1/2 long with flat bottom drilled in center with hole 3/8 deep and 3/8 dia.
- G - Treated carrier samples 1 by 6.

DIMENSIONS IN INCHES.

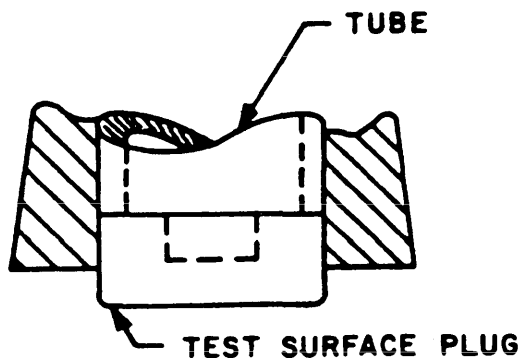

ENLARGED VIEW OF "F"

FIGURE 4. CIA test components



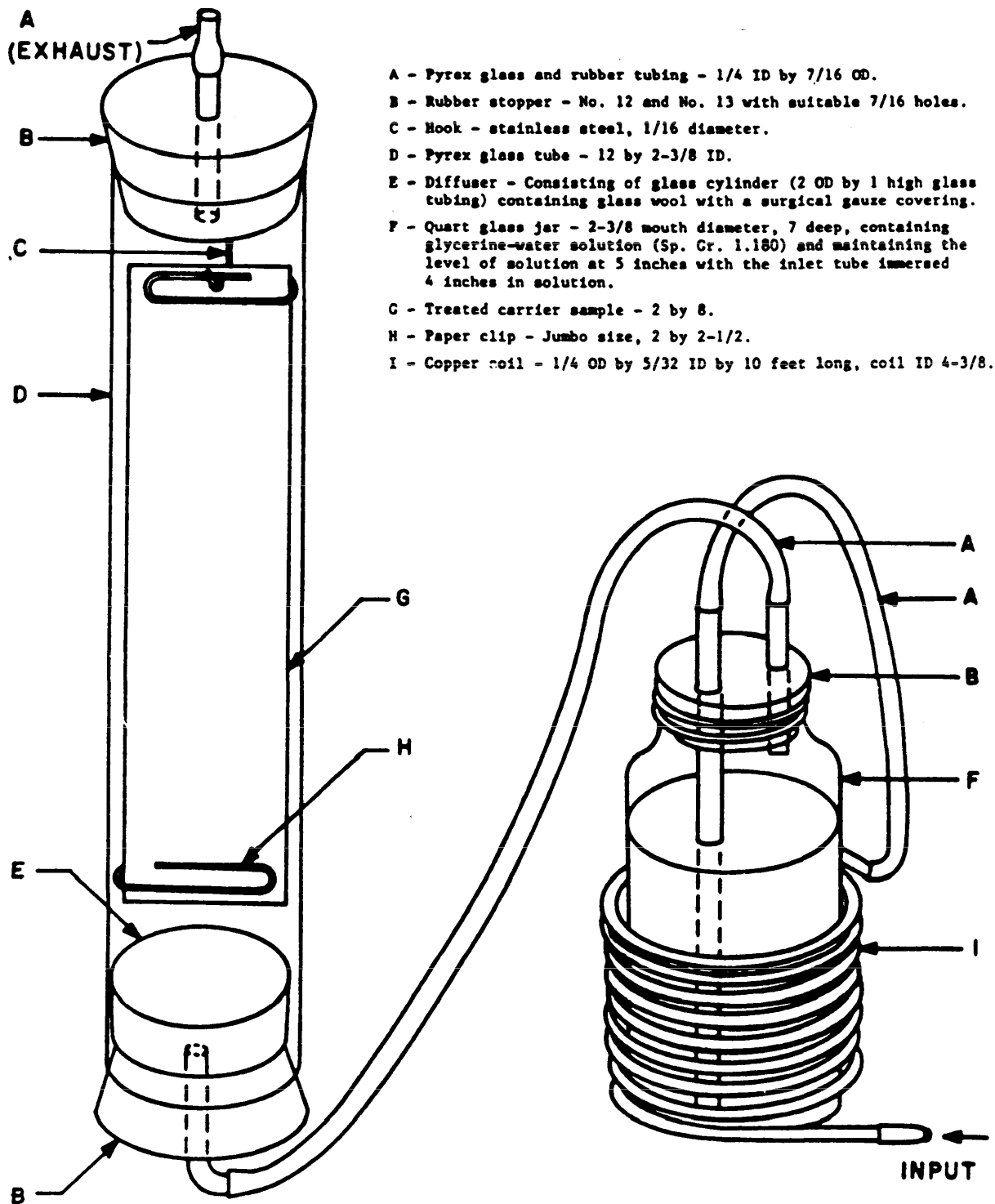
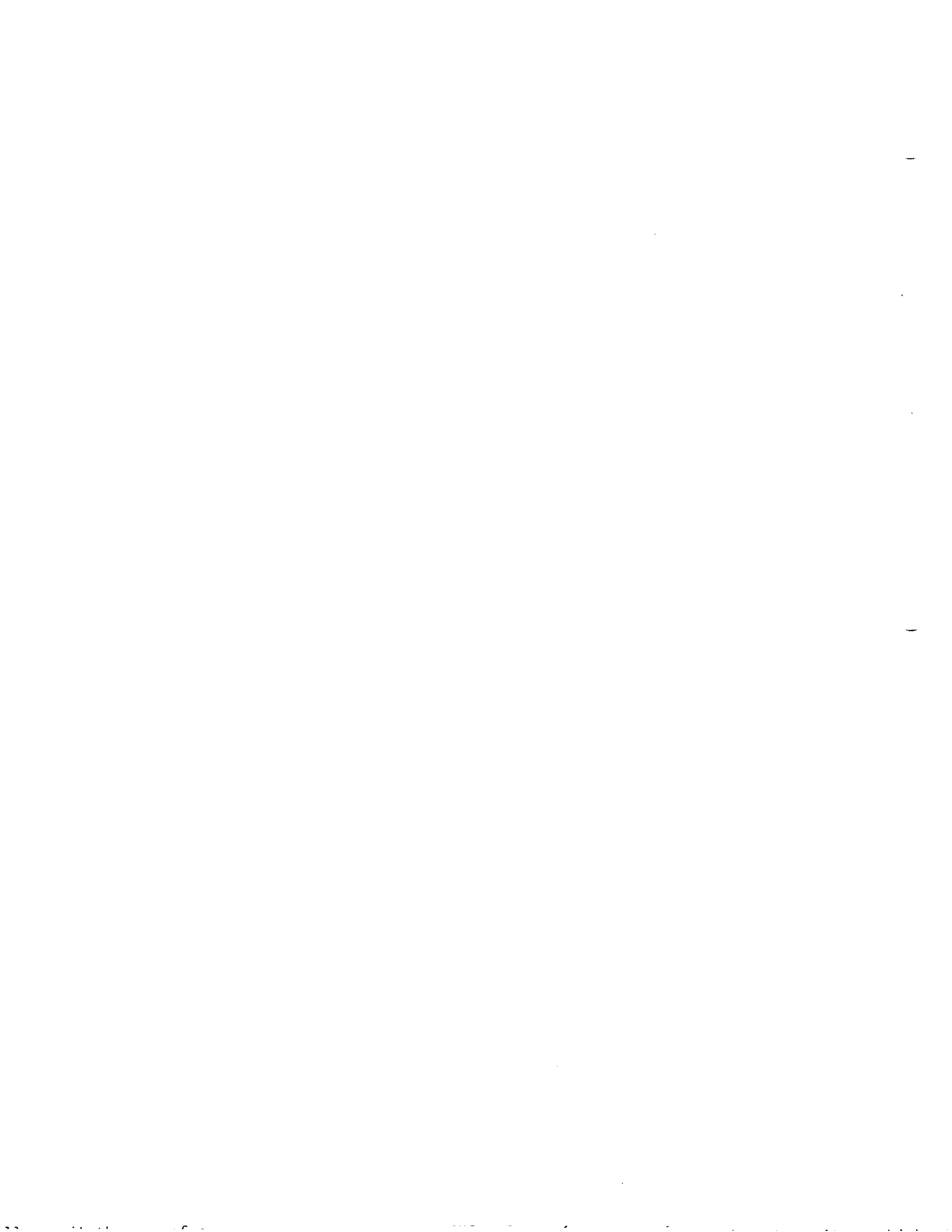

Figure 5. Apparatus for exhausting VCI-treated sheet material.



VISUAL EXAMINATION FOR TRANSPARENCY OR OPACITY

1. SCOPE

1.1 This method is for visually evaluating the transparency or opacity of a material by determining whether or not the material interferes with the legibility of type written paper labels or printed markings on steel.

2. DEFINITIONS

2.1 Not applicable.

3. APPARATUS

3.1 Standards for comparison. One or more of the following:

3.1.1 A colorless glass panel.

3.1.2 A duplicate specimen not exposed to adverse conditions.

3.1.3 A legibility standard. Unless otherwise specified, the following shall be used:

3.1.3.1 For paper label adhesive, the legibility standard shall be a white paper label upon which the ten digits and the lower case alphabet have been typed in black pica type.

3.1.3.2 For bag or window materials, the legibility standard shall be 10-point block style printing impressed to a depth not greater than 0.003 inch in a 2- by 4- by 1/8-inch panel of cold-rolled 1020 steel with the edges smoothed and the surface polished with 240 grit abrasive cloth or paper. Printing shall include the ten digits and the lower case alphabet.

3.2 Equipment appropriate to cut materials for specimens.

3.3 For fluid materials, appropriate equipment to apply the material and form specimens on colorless glass panels, typewritten white paper labels, or the 1020 steel panel described in 3.1.3.2.

3.4 Conditioning rooms, cabinets, or exposure chambers controlled to maintain the curing, aging, exposure, or test environment which, if desired, will be prescribed in the reference to this test.

3.5 Racks or fittings to support the specimen during the conditioning or exposure period.

4. SPECIMENS

4.1 A specimen of a production item, such as a transparent bag, shall be a representative item taken at random. The number taken shall be sufficient to adequately represent the variation within the lot.

4.2 A specimen of solid material (not fluid), such as the film material purchased to make transparent bags, shall be a piece or a quantity representative of the material.

4.3 A specimen of a viscous or fluid material, such as a transparent coating, shall be made from a representative sample of the material using the procedure prescribed in the reference to this test. If not there prescribed, specimens shall be prepared by applying the sample material in accord with the manufacturer's instructions for use of the material onto a colorless glass plate and the two legibility standards.

5. CONDITIONING

5.1 Unless otherwise specified, no conditioning other than prescribed for the drying or curing involved in preparation of the specimen is required.

6. PROCEDURE

6.1 Before and after the prescribed conditioning of the specimen, observe and note whether or not the material is sufficiently transparent so that the printing on the legibility standards is legible. Compare with legibility through clear glass and note any color apparent in the specimen when observing the white paper label. For specimens other than those applied onto the legibility standards, the specimen shall be 3 inches away from the legibility standards when making the observations.

7. REPORT

7.1 Immediately following each test the report (official record) of the facts pertinent to the test shall be completed, and shall include the following:

7.1.1 A statement that the test was conducted in compliance with this procedure, or a description of the deviations from this procedure. Report all options selected and details of otherwise specified procedure that were followed as permitted in 3.1, 3.3, 4.3 and 5.1.

7.1.2 Identification of the specimen and the specific material tested.

7.1.3 Results of the test. State whether or not the specimen was sufficiently transparent to read the legibility standard, and report any apparent color when observing the white paper.

7.1.4 When the test is performed to check compliance with requirements, state that the specimen did or did not meet the requirements and give the source for the requirements.

7.1.5 When the test is conducted to evaluate or compare products or methods, the report shall include a statement of any observations that may lead to improvements.

## 8. NOTES

8.1 This test method is an approximate method of judging opacity or transparency and is appropriate for most packaging materials. More precise methods are given in Methods 4019 and 4045. If a more precise test is prescribed, limits of acceptable quality must be prescribed in terms of the units measured by the test.

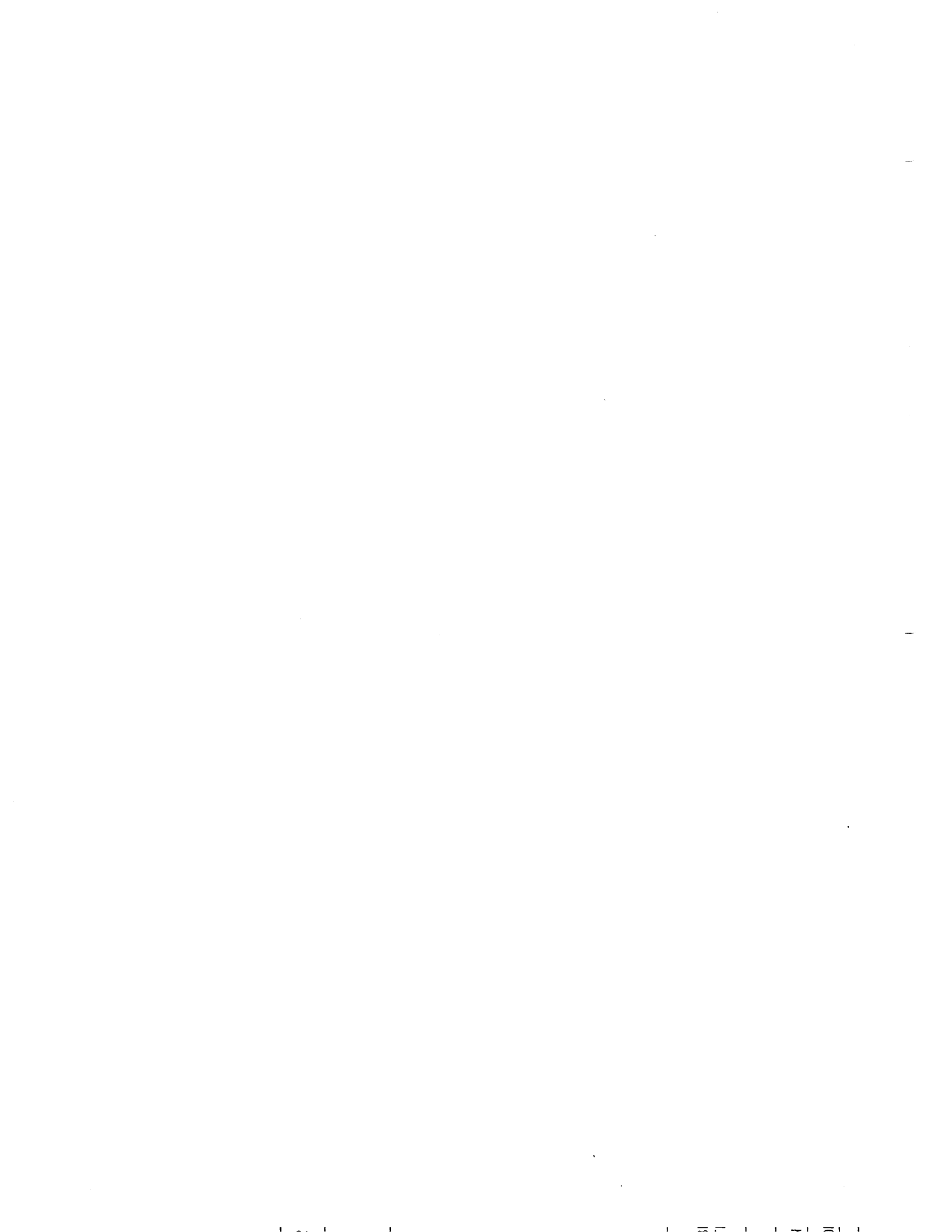

## ELECTROSTATIC PROPERTIES OF MATERIALS

### 1. SCOPE

1.1 This test is used to determine the electrostatic properties of materials in film and sheet form by measuring the intensity and polarity of an induced charge and the time required for complete dissipation of the induced charge.

1.2 This method does not determine the surface, volume or insulation resistivities of materials.

### 2. DEFINITION

2.1 Electrostatic properties are defined as the ability of a material, when grounded, to dissipate a charge induced on the surface of the material.

### 3. APPARATUS

3.1 A metal template, 5 by 3 by 1/8-inches.

3.2 A high voltage source, 0 to 15 KV, positive and negative.

3.3 An electrometer with a full scale reading of 0.01, 0.1, 1.0, 10 and 100, or a recording oscilloscope with a response of 1 microsecond per division, or equivalent.

3.4 A fabricated electrostatic test chamber with electrostatic test unit, illustrated in figures 1 through 5.

3.5 A single channel, pen type recorder with speeds of 0.5, 1.0, 2.0, 4.0, and 8.0 inches per minute and per second.

3.6 Four RG 114/U cables for connections between the detector and the electrometer and between the electrometer and the recorder. The nominal lengths of the cables are:

a. 5 inches for the connections between the detector and the output connector on the electrostatic test chamber.

b. 34 inches between the electrostatic test chamber and the electrometer, exclusive of the connectors.

c. 31.5 inches between the electrometer and the recorder (2 required).

3.7 Three-position control switch for connecting the test specimen to the high voltage source or the ground or neutral potential.

3.8 The equipment shall be assembled as illustrated in figure 2.

#### 4. SPECIMENS

4.1 Select specimens at random and in sufficient number to represent adequately the variation of the material. A minimum of three specimens per condition per sample are required.

4.2 Each specimen shall be 5 by 3 inches and shall be free of defects such as holes, cracks and tears. If the specimen is coated, the coating shall be continuous.

#### 5. CONDITIONING

5.1 Prior to testing, expose one-third of the specimens for 12 days in an oven uniformly maintained at  $160^{\circ} \pm 5^{\circ}\text{F}$ ; one-third of the specimens in a horizontal position for 24 hours under a continuous water shower; one-third of the specimens in an atmosphere uniformly maintained at  $73^{\circ} \pm 5^{\circ}$  and  $50 \pm 5$  percent relative humidity.

5.2 Unless otherwise specified, all specimens shall be placed in the electrostatic test chamber under conditions stated in 5.3 for a minimum of 24 hours immediately before testing, as specified in section 6.

5.3 Test environment. Perform tests in an atmosphere uniformly maintained at  $73^{\circ} \pm 5^{\circ}\text{F}$  and of less than 15 percent relative humidity. This relative humidity can be obtained by inserting sufficient anhydrous calcium chloride into the electrostatic test chamber. The anhydrous calcium chloride shall be replaced as required to maintain required relative humidity.

#### 6. PROCEDURE

##### 6.1 Calibration

6.1.1 Turn on all apparatus and allow to warm up, as noted in the operations manual for the particular apparatus.

6.1.2 On the electrometer, set "multiplier" switch to provide a half-scale reading when the test voltage is applied, the "operate" switch at "zero check" and the meter to read positive charge.

6.1.3 Adjust the high voltage for 5 KV positive output.



- 6.1.4 Mount a 1/8- by 3- by 5-inch aluminum panel between the electrodes in the electrostatic test unit so that the detector head is directly in the center of the panel. Tighten the four wing nuts to secure the panel.
- 6.1.5 Set speed of the recorder chart to 1 inch/min. Turn on recorder.
- 6.1.6 Set "operate" switch on the electrometer to "operate."
- 6.1.7 Turn three-position control switch to high voltage.
- 6.1.8 Observe that the reading on the recorder is identical with the measurement on the meter. Adjust the recorder if necessary.
- 6.1.9 Turn three-position control switch to ground to remove the charge from the test panel.
- 6.1.10 When the electrometer meter reaches zero, stop the recorder and turn the "operate" switch on the electrometer to "zero check."
- 6.1.11 Repeat the calibration procedure for 5 KV negative. Set the appropriate controls on the apparatus for negative charge.
- 6.2 TEST
  - 6.2.1 Each specimen, when tested, shall be mounted vertically between the electrodes and the wing nuts tightened to insure intimate contact between specimen and electrodes.
  - 6.2.2 Set recorder chart speed to 0.5 inch/second and turn on recorder.
  - 6.2.3 Set electrometer meter switch to indicate positive or negative charge, depending on the high voltage to be applied.
  - 6.2.4 Adjust the high voltage for the desired 5 KV potential.
  - 6.2.5 Set "operate" switch on electrometer to "operate."
  - 6.2.6 Turn the three-position control switch to high voltage.
  - 6.2.7 When the meter indication stops increasing, indicating the specimen has received its maximum charge, turn the three-position switch to ground position.
  - 6.2.8 When the meter needle reaches zero or after ten seconds, whichever comes first, stop recorder and move "operate" switch to "zero check."

METHOD 4046.1  
October 8, 1982  
CHANGE NOTICE 1

6.2.9 Charge each specimen three times for both positive and negative charges, allowing specimen to remain grounded for ten minutes after each charging cycle to remove any residual charge on the specimen. For non-homogeneous materials, both surfaces shall be charged by reversing the face of the material in contact with the inner electrodes.

6.2.10 Calculate charge decay time by measuring the horizontal distance on the chart from the point where the specimen was grounded to the point where the needle reached zero. With the speed of the chart known, calculate the decay time for each specimen in seconds.

7. REPORT

7.1 Report the facts pertinent to the test.

7.1.1 State that the test was conducted in accordance with this procedure or describe any deviations.

7.1.2 Identify the specimen and specific material tested.

7.1.3 Results of test.

7.1.3.1 State the decay time for each specimen for both positive and negative charges, as calculated in 6.2.10.

7.1.3.2 State that material was tested as received, aged, and after exposure to shower. Also state which surface was charged.

8. NOTES

8.1 The purpose of this procedure is to evaluate the electrostatic buildup and dissipation properties of packaging materials used to protect missile components and electronic parts that are susceptible to damage by electrostatic discharge.

8.2 The Keithley 621 Electrometer may be used. Other settings may apply if another suitable electrometer of different design is used.

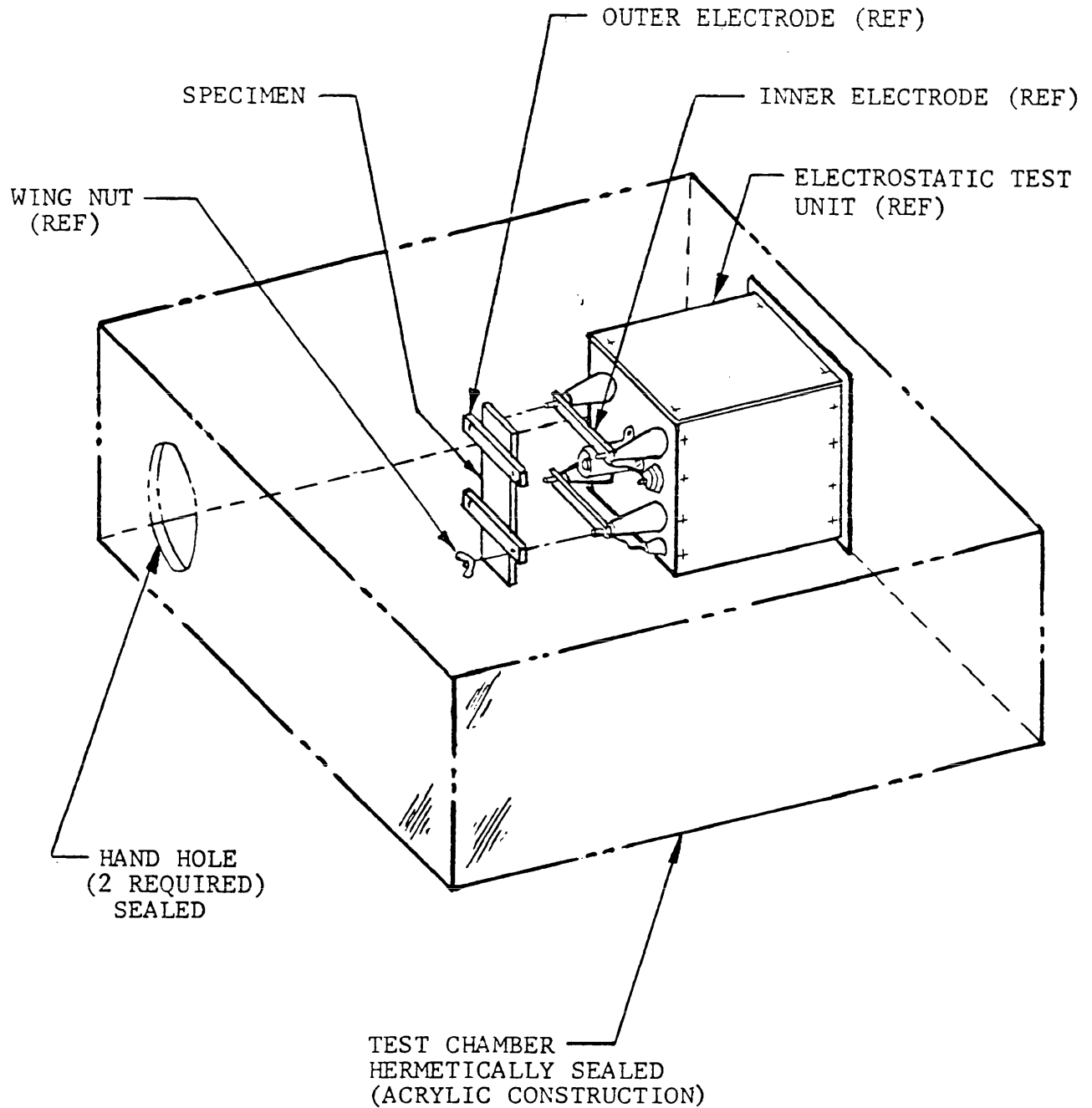

FIGURE 1. ELECTROSTATIC TEST CHAMBER

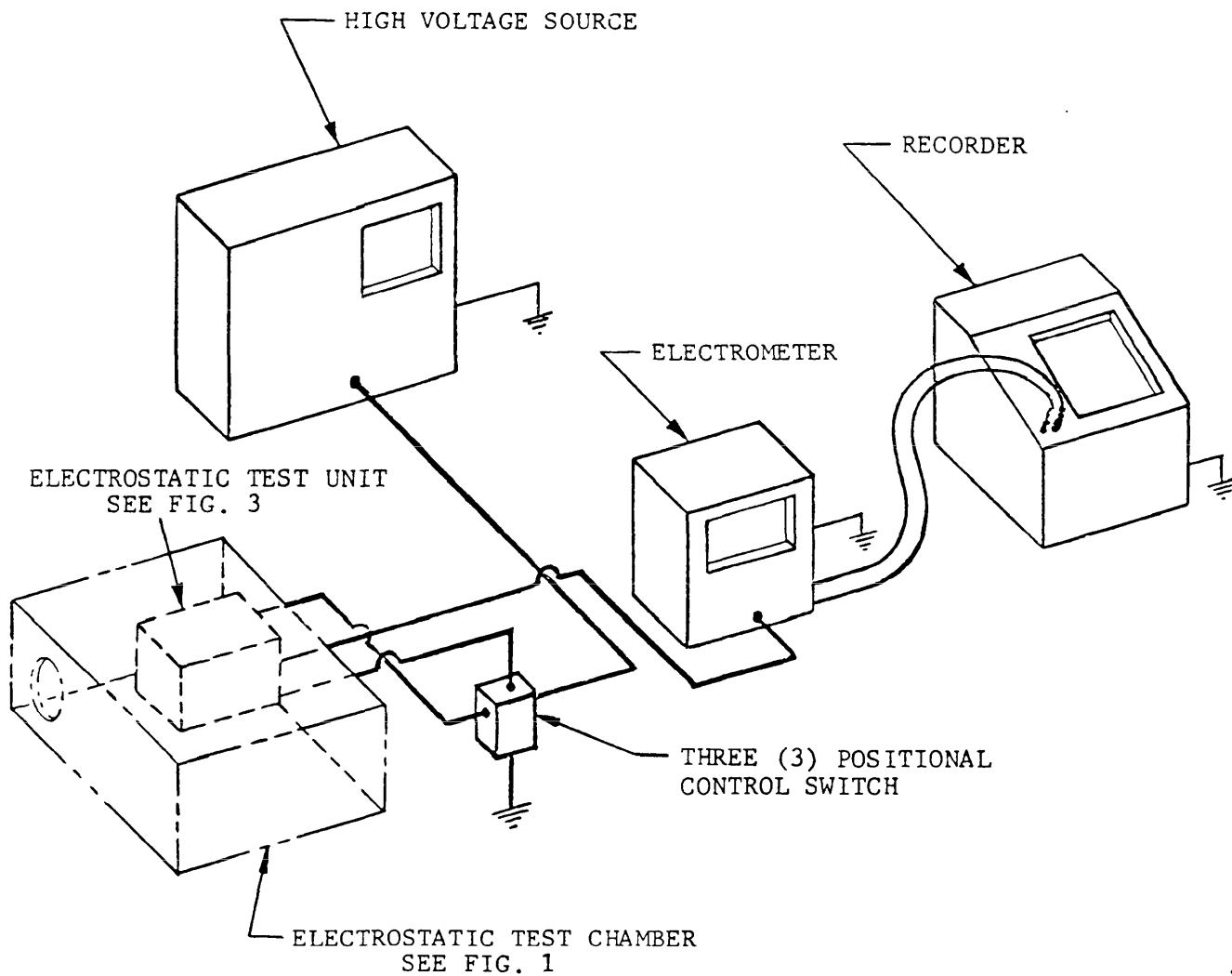
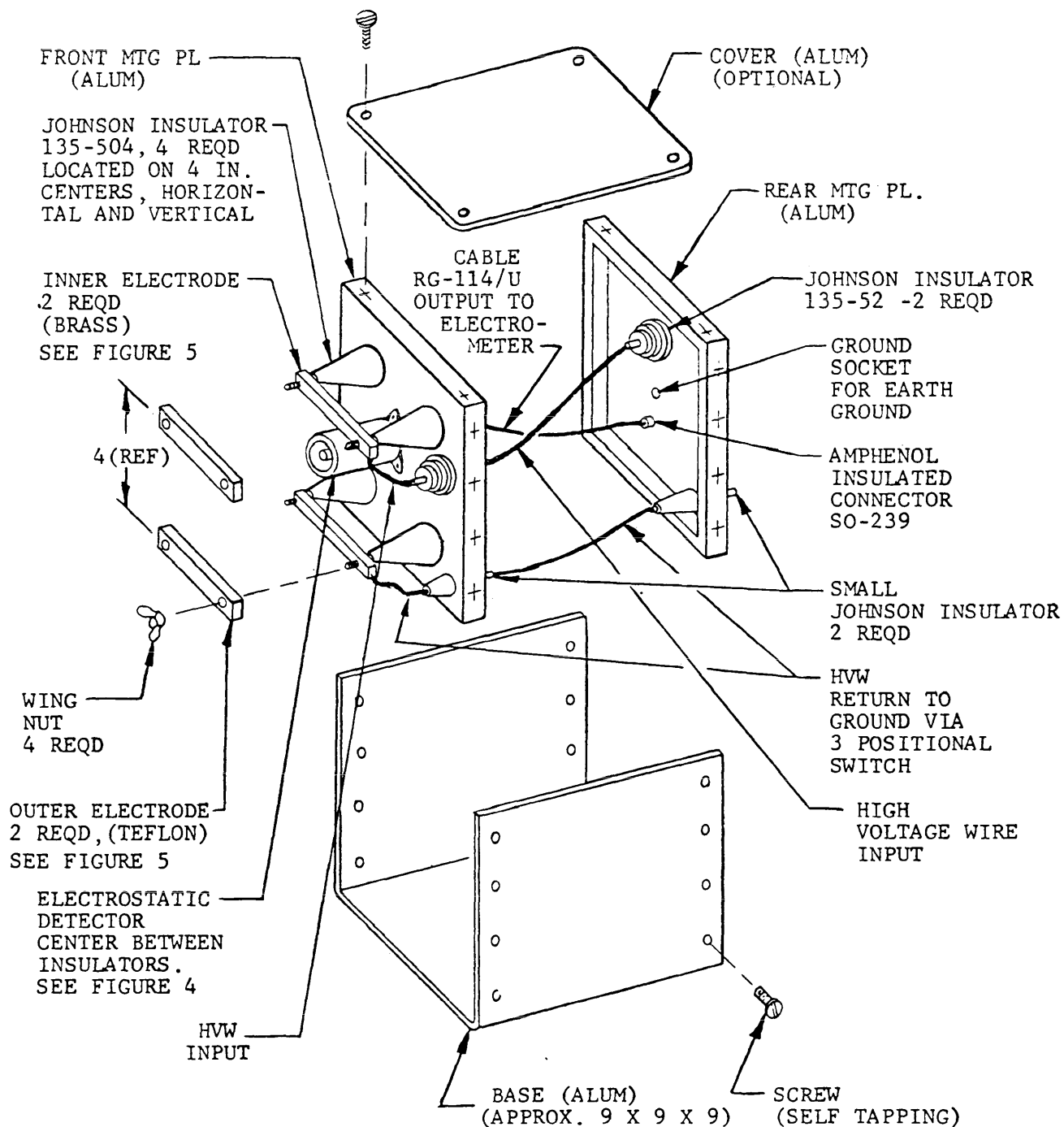

FIGURE 2. ELECTROSTATIC TEST ARRANGEMENT



NOTE: AFTER ASSEMBLY, THE BRASS DISC OF THE ELECTROSTATIC DETECTOR SHALL BE ADJUSTED SO THAT THE DISTANCE BETWEEN THE DISC AND A MOUNTED SPECIMEN IS APPROXIMATELY ONE INCH.

FIGURE 3. ELECTROSTATIC TEST UNIT

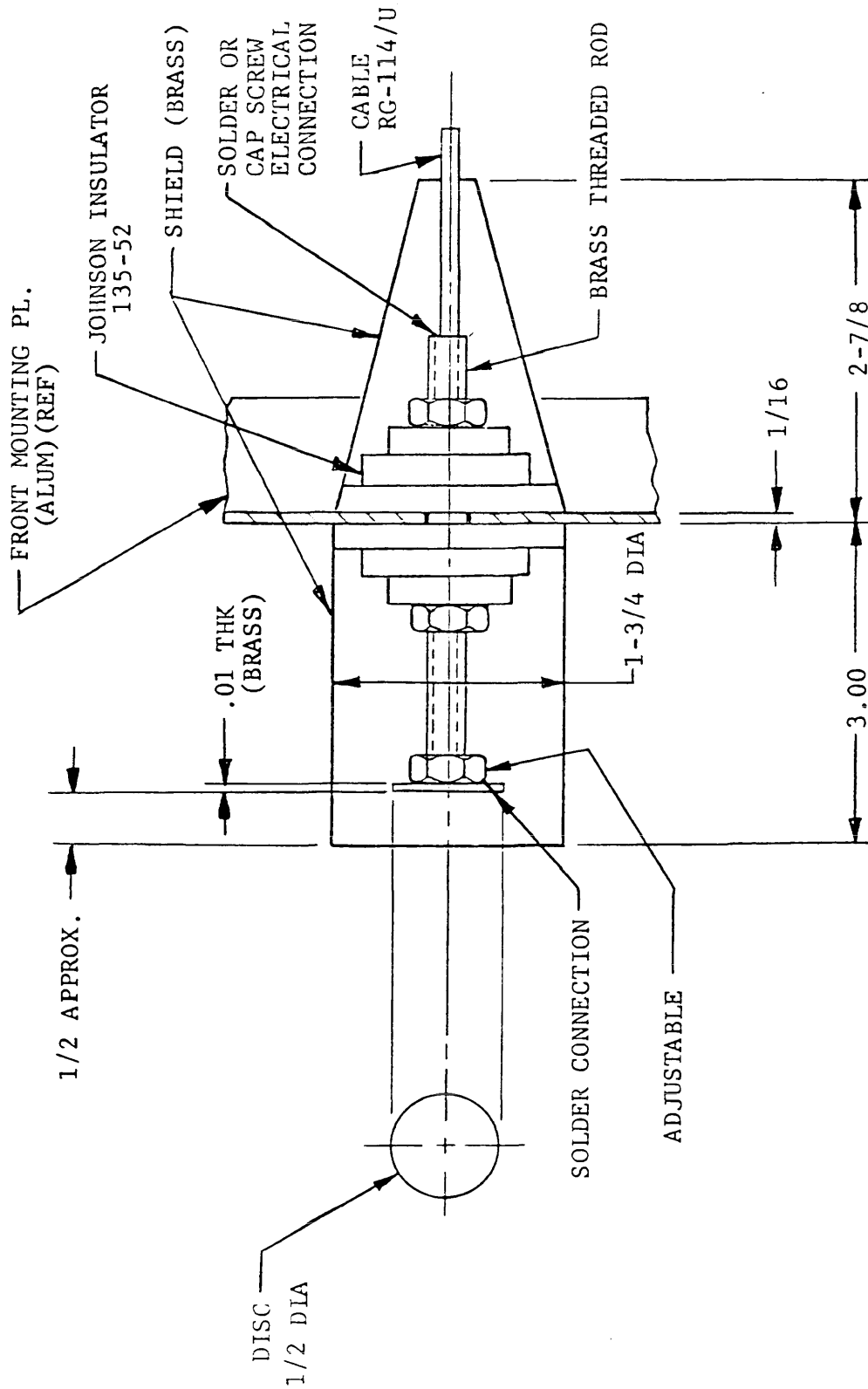

FIGURE 4. ELECTROSTATIC DETECTOR

METHOD 4046.1  
October 8, 1982  
CHANGE NOTICE 1

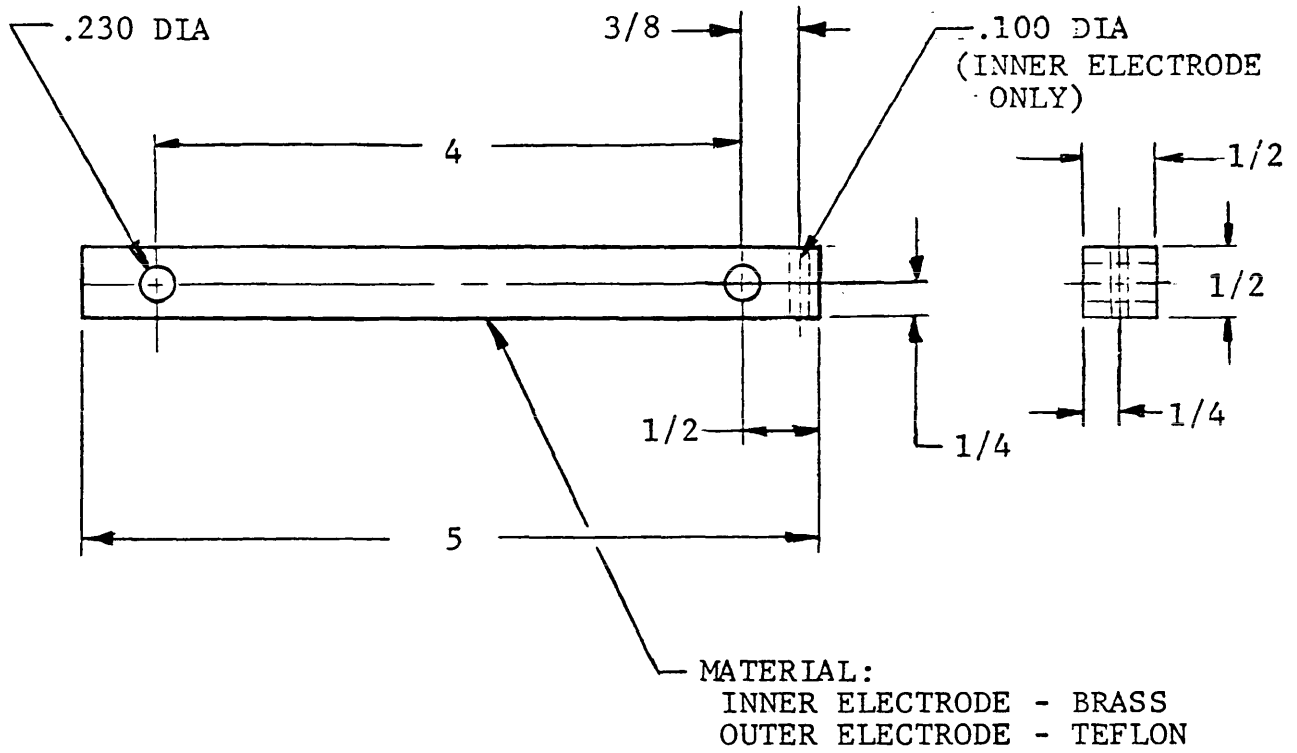
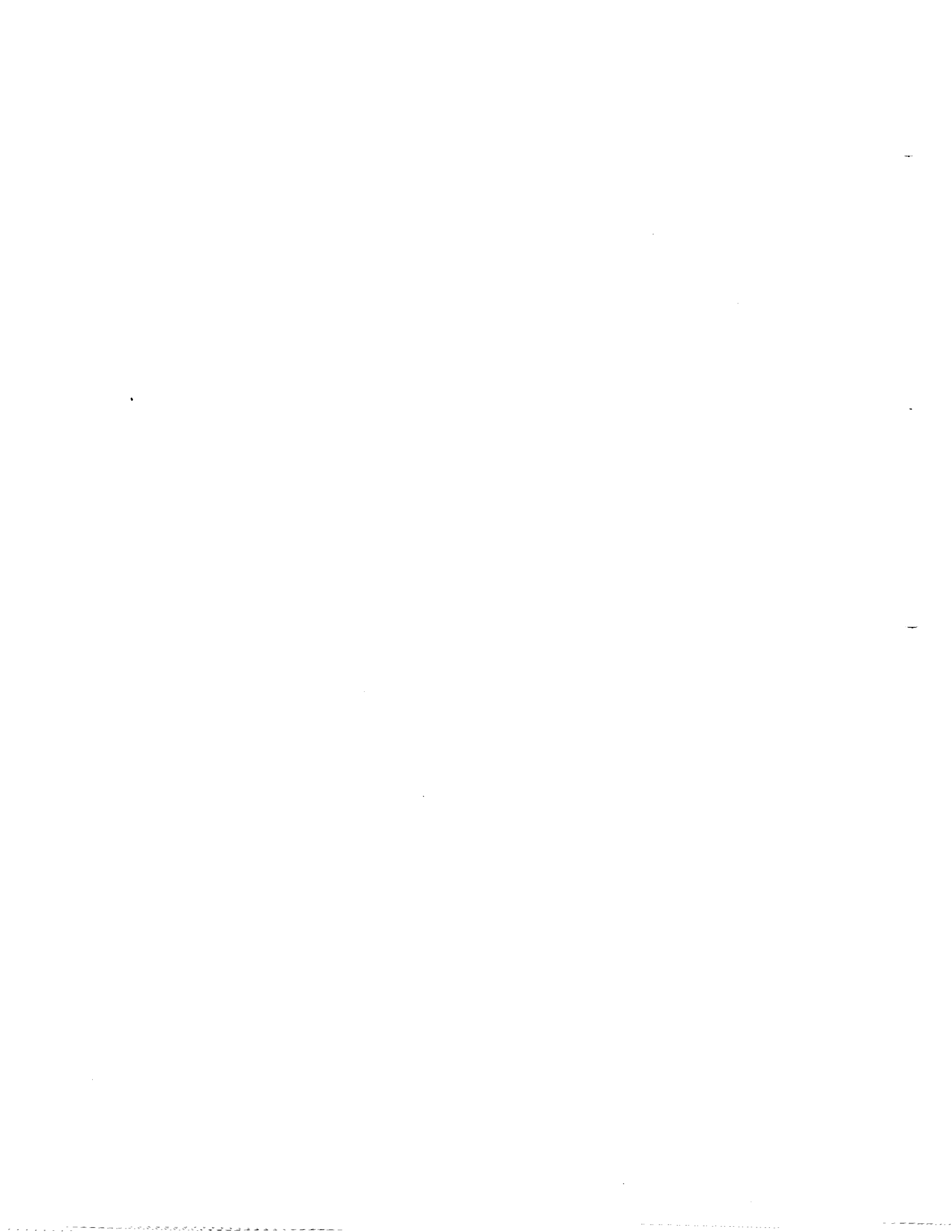

FIGURE 5. ELECTRODE





CORNERWISE-DROP (ROTATIONAL) TEST

1. SCOPE

1.1 The following procedure is applicable for determining the ability of large shipping containers to resist the impacts of being dropped on their corners and for determining the ability of the packaging and packing methods to provide protection to the contents when the pack is dropped on its corners.

2. DEFINITIONS

2.1 For the purpose of this test, a large shipping container may be a box, case, crate, other container constructed of wood, metal, or other material, or any combination of these for which the freefall drop test is not considered practical or adequate. Large containers shall be considered those having:

- (a) gross weight over 150 pounds,
- (b) length of any edge over 60 inches, or
- (c) gross weight under 150 pounds and the container is equipped with skids.

2.2 The level of packing to be provided for any item or contents is dependent upon the handling and shipping conditions which the container or pack may be expected to encounter. For the purpose of this standard, the levels of packing shall be defined as:

2.2.1 Level A. Level A is the degree of preservation or packing required for protection of materiel against the most severe conditions known or anticipated to be encountered during shipment, handling, and storage. Preservation and packing designated Level A will be designed to protect materiel against direct exposure to extremes of climate, terrain, operational and transportation environments without protection other than that provided by the pack. The conditions to be considered include, but are not limited to:

- (a) Multiple handling during transportation and intransit storage from point to origin to ultimate user.
- (b) Shock, vibration and static loading during shipment.
- (c) Loading on shipdeck, transfer at sea, helicopter delivery and offshore or over-the-beach discharge, to ultimate user.

- (d) Environmental exposure during shipment or during intransit operations where port and warehouse facilities are limited or non-existent.
- (e) Extended open storage in all climatic zones.
- (f) Static loads imposed by stacking.

2.2.2 Level B. Level B is the degree of preservation or packing required for protection of materiel under known favorable conditions during shipment, handling and storage. Preservation and packing designated Level B will be designed to protect materiel against physical damage and deterioration during favorable conditions of shipment, handling and storage. The conditions to be considered include but are not limited to:

- (a) Multiple handling during transportation and intransit storage.
- (b) Shock, vibration and static loading of shipment worldwide by truck, rail, aircraft, or ocean transport.
- (c) Favorable warehouse environment for extended periods.
- (d) Environmental exposure during shipment and intransit transfers, excluding deck loading and offshore cargo discharge.
- (e) Stacking and supporting superimposed loads during shipment and extended storage.

### 3. APPARATUS

3.1 In conducting the cornerwise-drop test, the container may be handled with any convenient equipment, such as a forklift truck, a hoist, or a block and tackle. A smooth, level, concrete surface (or similarly unyielding surface) shall be used in performing the cornerwise-drop test.

### 4. SPECIMEN

4.1 One container and its contents shall constitute a single specimen. The container shall be loaded for the test with the interior packing and the actual contents for which it was designed. If use of the actual contents is not practical, a dummy load shall be substituted to simulate such contents in weight, rigidity, shape, and center of gravity, position in the container, and appropriately instrumented to record shock forces or deflections during the test. The contents, or dummy load, shall be blocked, braced, and cushioned in place as for shipment.

5.           CONDITIONING OF SPECIMEN

5.1           All tests shall be conducted at room temperature ( $70^{\circ} \pm 20^{\circ}\text{F}$ ) except as noted below.

6.           PROCEDURE

6.1           The specimen shall be placed on its bottom. One corner of the base of the container shall be supported on a block nominally 6 inches in height, and a block nominally 12 inches in height shall be placed under the other corner of the same end. If the dimensions of the container are such that the 12-inch height cannot be attained without instability, a block of the greatest attainable height shall be substituted. These heights shall be increased, if necessary, to insure that there will be no support for the base between the ends of the container when dropping takes place, but should not be high enough to cause the container to slide on the supports when the drop end is raised for the drop. The unsupported end of the container shall be raised so that the lower corner of that end reaches the prescribed height and then allowed to fall freely to the concrete surface or similarly unyielding surface (see figure 1). Unless otherwise specified, the height of drop for Levels A and B protection shall conform to Table I; the maximum heights shall not exceed 36 inches and 27 inches respectively.

Unless otherwise specified, there shall be one drop on each corner of the container base (four drops). If the test specimen contains materials which are significantly affected by temperature the test shall be conducted while the container is stabilized at the extremes of temperature. In this case, one drop shall be made on each of two diagonally opposite corners at  $-20^{\circ} \pm 5^{\circ}\text{F}$ . The test specimen shall be allowed to come normally to room temperature prior to conditioning at the other extreme. One drop shall then be made on each of the other two diagonally opposite corners at  $140^{\circ} \pm 5^{\circ}\text{F}$ . Thus, a total of four drops constitutes a complete test.

7.           REPORT

7.1           Following the test a report shall be written which shall include the following:

7.1.1        A statement that the test was conducted in compliance with this procedure, or a description of the deviation from this procedure. Report all options selected and "otherwise specified" details that were followed as permitted in 2.1, 5.1 and 6.1.

7.1.2        Container dimensions, container structural details, type of materials used, spacing, size, and type of fasteners, methods of closing and strapping, and the net and gross weights.

7.1.3 A description of the contents of the container including blocking, bracing, cushioning, or isolation system.

7.1.4 The results of the test, describing the final condition of both container and contents.

7.1.5 When the test is conducted to determine satisfactory performance of a container or pack, the report shall include a statement that the container or pack either attained or did not attain the specified performance. If not specified elsewhere, it is suggested that the following be cause for rejection:

- (a) Functional or physical damage to the contents.
- (b) Functional damage to the container.
- (c) Shock forces on the contents (or dummy load) which exceeds the established fragility of the contents.
- (d) Failure of a vapor or waterproof container to prevent vapor transmission or water leakage within specified limits.
- (e) Structural damage to the container which may result in damage to the contents during subsequent shipping, handling, or storage. Substantial spillage, exposure, or shifting of the contents are examples of such damage. Minor damage such as dents, paint chipping, or the crushing of wood members which do not impair the function of the container are not causes for rejection.

7.1.6 The report should include information, acquired through observation, to improve container or methods of packing.

## 8. NOTES

8.1 This test is meant to simulate the impacts of accidentally dropping a container on its corners. It is intended that the cornerwise-drop test shall be used only on containers that are susceptible to accidental cornerwise drops. The cornerwise-drop test was designed specifically for large and/or heavy shipping containers that are likely to be handled mechanically rather than manually. Details are given with the qualification, "unless otherwise specified," in paragraphs regarding:

- Definition of large container (2.1).
- Conditioning of specimens (5.1).
- Number and height of drops (6.1).

8.2 When the cornerwise-drop test is performed to evaluate the protection provided for the contents, the rigidity of a dummy load should closely approximate that of the actual contents for which the container was designed.

Table I. Height of rotational drops for containers of various sizes and weights 1/

Gross weight (within range limits)	Dimensions of any edge, height or width (within range limits)	Height of drop on corners	
		Level A inches	Level B inches
Pounds	Inches		
150 - 250	60 - 66	36	27
250 - 400	66 - 72	32	24
400 - 600	72 - 80	28	21
600 - 1000	80 - 95	24	18
1000 - 1500	95 - 114	20	16
1500 - 2000	114 - 144	17	14
2000 - 3000	Above 144 - No limit	15	12
Above -3000		12	9

1/ Use the lowest drop height indicated by either gross weight or dimension. For example, a container having a gross weight of 440 lbs. and a maximum edge dimension of 95-5/8" shall be dropped 20 inches for Level A tests, or 16 inches for Level B tests.

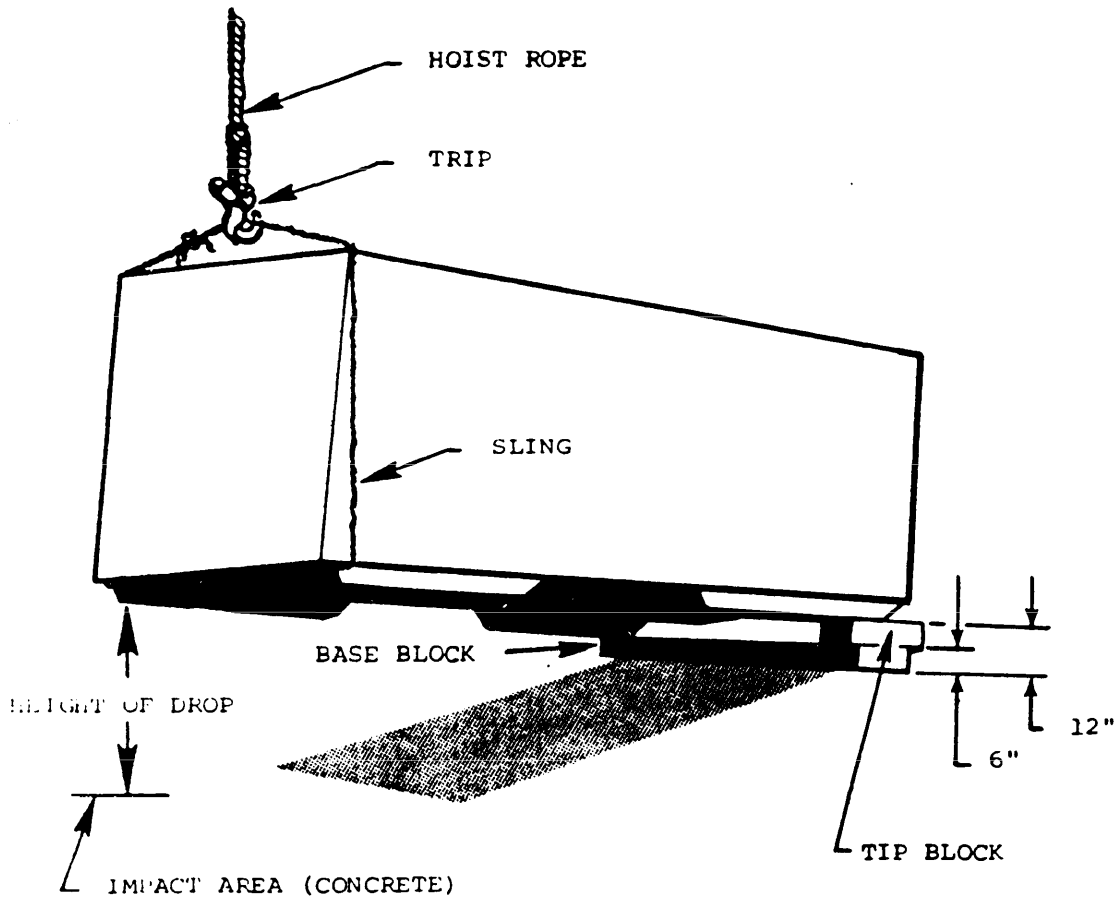

Figure 1. Cornerwise drop (Rotational)

## FREE FALL DROP TEST

### 1. SCOPE

1.1 The following procedure is for determining the ability of containers to withstand impacts and the ability of packaging and packing methods to protect the contents when the pack is subjected to free-fall drops. This procedure is appropriate for use with all containers weighing up to 150 lbs, except those with skids or those having any edge or diameter over 60 inches.

### 2. DEFINITIONS

2.1 The level of packing to be provided for any item or contents is dependent upon the handling, shipping, and storage conditions which the container or pack may be expected to encounter. For the purpose of this standard, the levels of packing shall be defined as:

2.2.1 Level A is the degree of preservation of packing required for protection of materiel against the most severe conditions known or anticipated to be encountered during shipment, handling, and storage. Preservation and packing designated Level A will be designed to protect materiel against direct exposure to extremes of climate, terrain, operational and transportation environments without protection other than that provided by the pack. The conditions to be considered include, but are not limited to:

- (a) Multiple handling during transportation and intransit storage from point of origin to ultimate user.
- (b) Shock, vibration and static loading during shipment.
- (c) Loading on shipdeck, transfer at sea, helicopter delivery and offshore or over-the-beach discharge, to ultimate user.
- (d) Environmental exposure during shipment or during intransit operations where port and warehouse facilities are limited or non-existent.
- (e) Extended open storage in all climatic zones.
- (f) Static loads imposed by stacking.

2.2.2 Level B is the degree of preservation or packing required for protection of materiel under known favorable conditions during shipment, handling and storage. Preservation and packing designated Level B will be designed to protect materiel against physical damage and deterioration during favorable conditions of shipment, handling and storage. The conditions to be considered include but are not limited to:

- (a) Multiple handling during transportation and intransit storage.
- (b) Shock, vibration and static loading of shipment worldwide by truck, rail, aircraft or ocean transport.
- (c) Favorable warehouse environment for extended periods.
- (d) Environmental exposure during shipment and intransit transfers, excluding deck loading and offshore cargo discharge.
- (e) Stacking and supporting superimposed loads during shipment and extended storage.

3. APPARATUS

3.1 Any suitable apparatus may be used that conforms to the following requirements:

- 3.1.1 Permits the container to be placed in a position prior to release that will assure free unobstructed fall to impact the container at the orientation and in the direction required.
- 3.1.2 Permits accurate and convenient control of the height of drop.
- 3.1.3 Utilizes lifting devices that will not damage the containers.
- 3.1.4 Provides an instantaneous release mechanism that does not impart rotational or sidewise forces to the test container.
- 3.1.5 Provides a rigid and level steel surface not less than 1/2-inch-thick integral with a solid mass of concrete, steel, or stone sufficient to absorb all shock without displacement.
- 3.1.6 Provides, when required by detail specification, an additional and properly positioned hazard to test a container's ability to protect a specific point of critical vulnerability of its contents. This hazard shall consist of a straight block of oak or other relatively heavy



hard wood 4 by 4 at least 24 inches long with the edges rounded to a radius of 1/4 inch plus or minus 1/16 inch. The detail specifications shall include any further description of the impacting object, the attitude, the point of impact, height, and number of drops.

4. SPECIMEN

4.1 One container and its contents shall constitute a single specimen. The container shall be loaded for the test with the interior packing and the actual contents for which it was designed. If use of the actual contents is not practical, a dummy load shall be substituted to simulate such contents with weight, rigidity, shape, and center of gravity position in the container. The contents, or dummy load, shall be blocked, braced, and cushioned in place as for shipment and appropriately instrumented to record shock forces or deflections during the test.

5. CONDITIONING

5.1 All tests shall be conducted at room temperature ( $70^{\circ} \pm 20^{\circ}\text{F}$ ) except as noted below.

6. PROCEDURE

6.1 Bags. Unless otherwise specified, each bag specimen shall be dropped once on the filling end and once flatwise (seams horizontal) from a height of 48 inches.

6.2 Cylindrical containers. Unless otherwise specified, cylindrical containers, barrels, pails, etc., shall be subjected to one of the procedures described below. The container is to be dropped once flatwise on each end. The top and bottom rim or chime drops are to be made wherein the container center or gravity is directly above the striking point at the instant of release. A plumb line aligned with the center point of the drop table (see Figure 1) may be used to position the container. The rim drop shall be made in pairs, one on the top rim and one on the bottom rim. For the two drops of each pair, the container shall strike on diagonally opposite quadrants of the top and bottom rims. If a total of more than four rim drops is specified, the additional drops shall be on sections not previously dropped upon.

Procedure A. One drop on each end (2 drops)

Procedure B. One drop on each half of the top and bottom rims (4 drops)

- Procedure C. One drop on each quadrant of the top and bottom rims (8 drops)
- Procedure D. One drop on each half of the top and bottom rims, one drop on each end, and two drops on the cylindrical side of the container at 90° to each other (8 drops).

6.3 Rectangular containers. Unless otherwise specified, rectangular containers shall be subjected to one or more of the following procedures, as described below, but dropped not more than once on any flat face, edge, or corner. For edgewise drops the striking edge of the package shall be parallel with the dropping surface at the instant of release. For edgewise and cornerwise drops the package center of gravity shall be directly above the striking edge or corner of the package at the instant of release (see Figure 1).

- Procedure A. One drop on each flat face, edge and corner (26 drops).
- Procedure B. One drop on each flat face (6 drops).
- Procedure C. One cornerwise drop followed by one edgewise drop on each of the three edges radiating from the struck corner (4 drops).
- Procedure D. One cornerwise drop on each of the four bottom corners (4 drops).
- Procedure E. One cornerwise drop on each of the eight corners (8 drops).
- Procedure F. One drop on each edge (12 drops).
- Procedure G. One cornerwise drop on each of two sets of diagonally opposite corners; followed by one flat drop on the bottom, top, and two adjacent sides (8 drops).

If the test specimen contains materials which are significantly affected by temperature the test shall be conducted at the specified temperature extremes. Unless otherwise specified, half of the drops indicated by the above procedures shall be made at a stabilized temperature of  $-20^{\circ} + 5^{\circ}\text{F}$  and half shall be made at a temperature of  $140^{\circ} + 5^{\circ}\text{F}$ .

6.4 Drop height. All package drops shall be made so that the package falls freely through the specified vertical free-fall distance. (See Table I.)

## 7. REPORT

7.1 Following the test a report shall be written which shall include the following:

7.1.1 A statement that the test was conducted in compliance with this procedure or a description of the deviation from this procedure. Report all options selected and "otherwise specified" details that were followed as permitted in 2.1, 5.1, and 6.1.

7.1.2 Container dimensions, container structural details, type of materials used, spacing, size and type of fasteners, methods of closing and strapping, and the net and gross weights.

7.1.3 A description of the contents of the container including blocking, bracing, and cushioning.

7.1.4 The results of the test, describing the final condition of both container and contents.

7.1.5 When the test is conducted to determine satisfactory performance of a container or pack, the report shall include a statement that the container or pack either attained or did not attain the specified performance. If not specified elsewhere, it is suggested that the following be cause for rejection.

- (a) Functional or physical damage to the contents.
- (b) Functional damage to the container.
- (c) Shock forces on the contents (or dummy load) which exceeds the established fragility of the contents.
- (d) Failure of a vapor or waterproof container to prevent vapor transmission or water leakage within specified limits.
- (e) Structural damage to the container which may result in damage to the contents during subsequent shipping, handling, or storage. Substantial spillage, exposure, or shifting of the contents are examples of such damage. Minor damage such as dents, paint chipping, or the crushing of wood members which do not impair the function of the container are not causes for rejection.

7.1.6 The report should include information acquired through observation to improve the container or methods of packing.

8. NOTES

8.1 This method specifically describes only the free drop test procedure. If other tests on the container, such as a preceding exposure test or a subsequent leakage test, are desired, then such tests and their sequence should be specified. In this free drop test procedure, details are given with the qualification "unless otherwise specified" in paragraphs regarding:

- Conditioning of specimens (5.1).
- Height of drop, number of drops, points of impact (6.1, 6.2, and 6.3).

This test is meant to simulate the impacts of accidentally dropping a container on its edges, corners or flat surfaces.

Table I. Height of free fall drops for containers of various sizes and weights 1/ 2/

Gross weight (within range limits)	Dimension of any edge, height, or diameter (within range limits)	Height of free fall drop on corners or edges, or flat faces	
		Level A Inches	Level B Inches
Pounds	Inches		
0 - 15	0 - 30	36	27
15 - 30	30 - 33	30	22
30 - 50	33 - 37	25	19
50 - 75	37 - 42	21	17
75 - 110	42 - 50	19	15
110 - 150	50 - 60	18	14

1/ Use the lowest drop height indicated by either gross weight or dimension. For example, a container having a gross weight of 36 lbs. and a maximum edge dimension of 42-5/8" shall be dropped 19 inches for Level A, or 15 inches for Level B.

2/ Containers with gross weight or any one dimension exceeding 150 pounds or 60 inches respectively should not be tested by the free-fall method unless warranted by exceptional package design or intended use. (See edgewise and cornerwise drop tests and tipover test.)

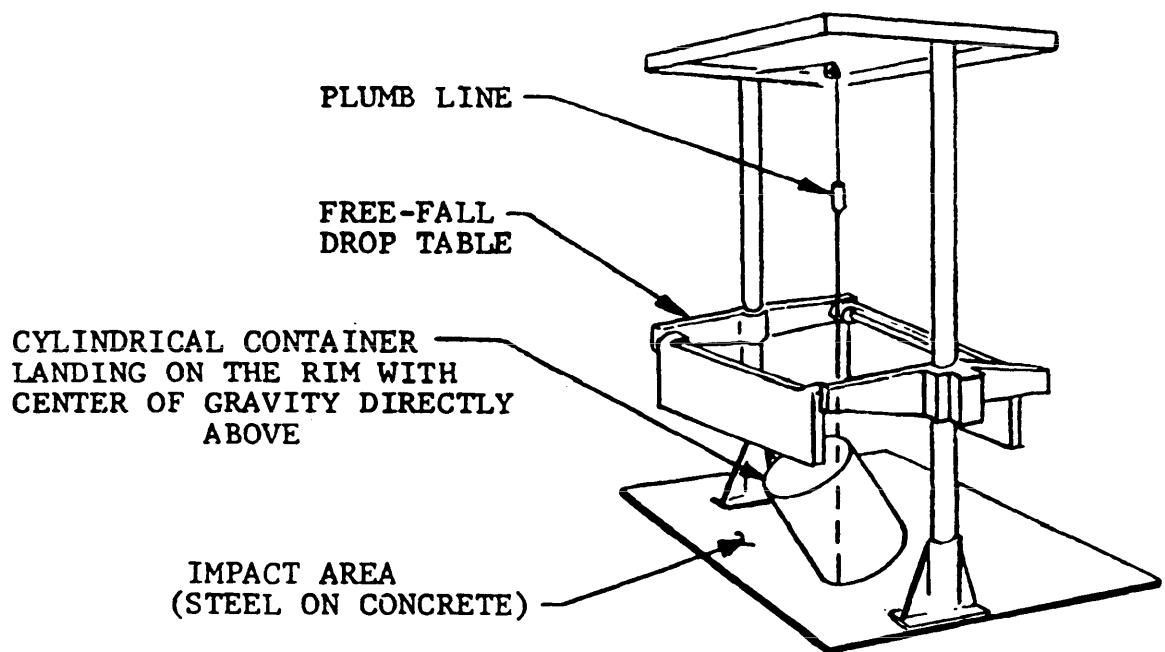
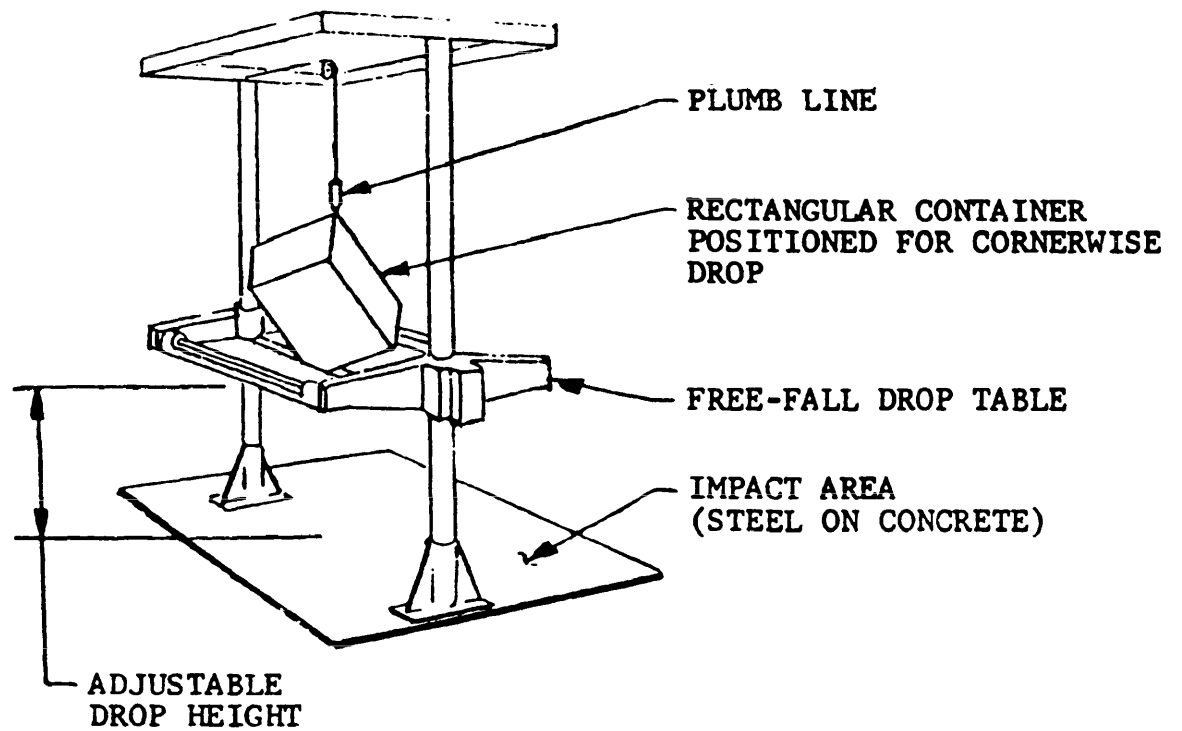
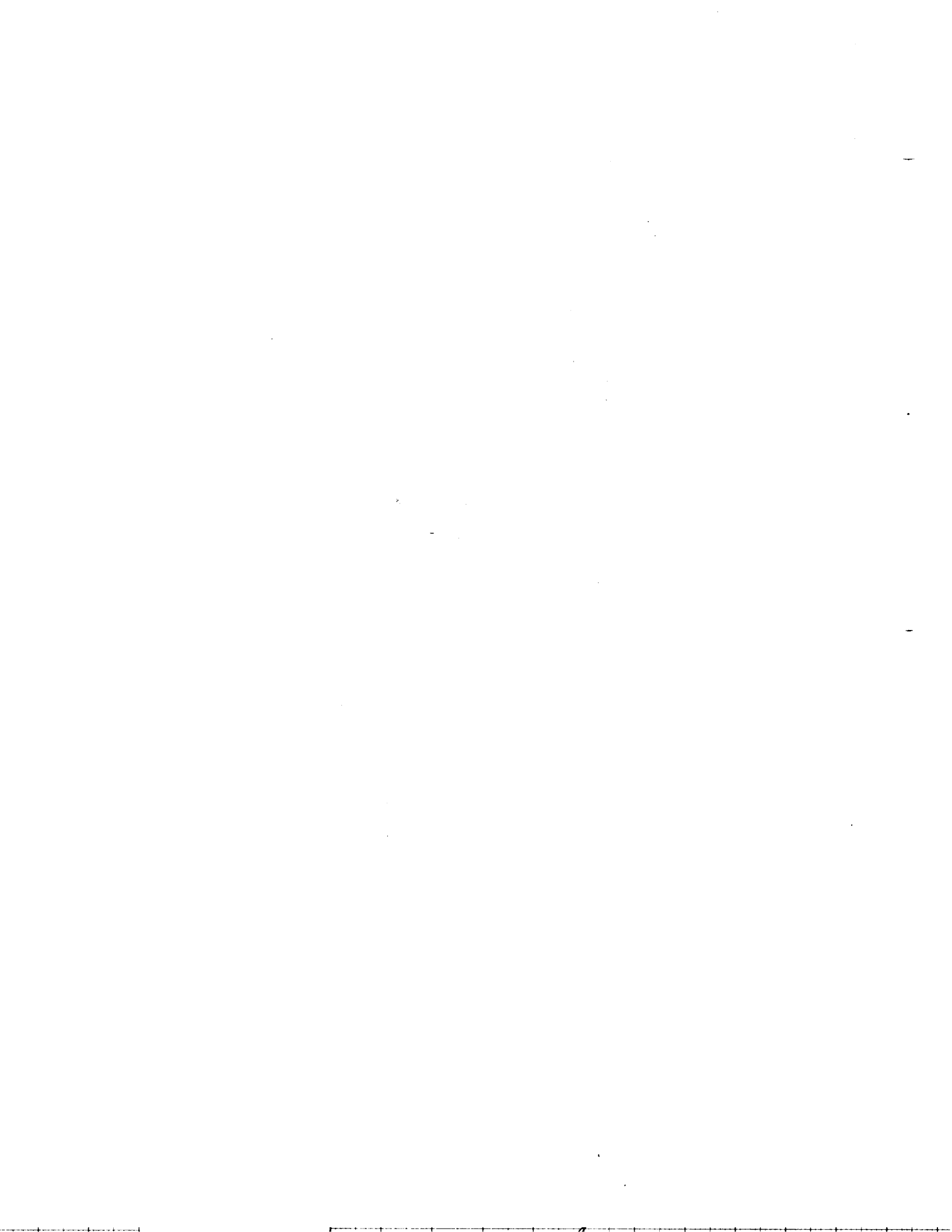

Figure 1. Free-fall drop test.



EDGEWISE-DROP (ROTATIONAL) TEST

1. SCOPE

1.1 The following procedure is applicable for determining the ability of large shipping containers to resist the impacts of being dropped on their edges and for determining the ability of the packaging and packing methods to provide protection to the contents when the pack is dropped on its edges.

2. DEFINITIONS

2.1 For the purpose of this test, a large shipping container may be a box, case, crate, or other container constructed of wood, metal, or other material, or any combination of these for which the free fall drop test is not considered practical or adequate. Large containers shall be considered those having:

- (a) gross weight over 150 pounds,
- (b) length of any edge over 60 inches, or
- (c) gross weight under 150 pounds and the container is equipped with skids.

2.2 The level of packing to be provided for any item or contents is dependent upon the handling and shipping conditions which the container or pack may be expected to encounter. For the purpose of this standard the levels of packing shall be defined as:

2.2.1 Level A is the degree of preservation or packing required for protection of materiel against the most severe conditions known or anticipated to be encountered during shipment, handling, and storage. Preservation and packing designated Level A will be designed to protect materiel against direct exposure to extremes of climate, terrain, operational and transportation environments without protection other than that provided by the pack. The conditions to be considered include, but are not limited to:

- (a) Multiple handling during transportation and intransit storage from point of origin to ultimate user.
- (b) Shock, vibration and static loading during shipment.

- (c) Loading on shipdeck, transfer at sea, helicopter delivery and offshore or over-the-beach discharge, to ultimate user.
- (d) Environmental exposure during shipment or during intransit operations where port and warehouse facilities are limited or non-existent.
- (e) Extended open storage in all climatic zones.
- (f) Static loads imposed by stacking.

2.2.2 Level B is the degree of preservation of packing required for protection of materiel under known favorable conditions during shipment, handling and storage. Preservation and packing designated Level B will be designed to protect materiel against physical damage and deterioration during favorable conditions of shipment, handling and storage. The conditions to be considered include but are not limited to:

- (a) Multiple handling during transportation and intransit storage.
- (b) Shock, vibration and static loading of shipment worldwide by truck, rail, aircraft, or ocean transport.
- (c) Favorable warehouse environment for extended periods.
- (d) Environmental exposure during shipment and intransit transfers, excluding deck loading and offshore cargo discharge.
- (e) Stacking and supporting superimposed loads during shipment and extended storage.

### 3. APPARATUS

3.1 In conducting the edgewise-drop test, the container may be handled with any convenient equipment, such as a forklift truck, a hoist, or a block and tackle. A smooth, level, concrete surface (or similarly unyielding surface) shall be used in performing the edgewise-drop test.

### 4. SPECIMEN

4.1 One container and its contents shall constitute a single specimen. The container shall be loaded for the test with the interior packing and the actual contents for which it was designed. If use of the actual contents is not practical, a dummy load shall be substituted to simulate such contents in weight, rigidity, shape, and center of gravity position in the container and appropriately instrumented to



record shock forces or deflections during the test. The contents or dummy load, shall be blocked, braced, and cushioned in place as for shipment.

5.           CONDITIONING OF SPECIMEN

5.1           All tests shall be conducted at room temperature  $70^{\circ} \pm 20^{\circ}\text{F}$ ).

6.           PROCEDURE

6.1           The specimen shall be placed on its bottom with one end of the base of the container supported on a sill nominally 6 inches high. The height of the sill shall be increased if necessary to insure that there will be no support for the base between the ends of the container when dropping takes place, but should not be high enough to cause the container to slide on the supports when the drop end is raised for the drop. The unsupported end of the container shall then be raised and allowed to fall freely to the concrete surface or similarly unyielding surface from a prescribed height (see figure 1). Unless otherwise specified, the height of drop for Levels A and B protection shall conform to Table I. The maximum heights shall not exceed 36 inches for Level A and 27 inches for Level B protection.

Unless otherwise specified, a total of four drops constitute a complete test. If the size of the container and the location of the center of gravity are such that the drop cannot be made from the prescribed height, the height of the sill shall be increased. Rectangular containers shall be dropped once on each edge of the container base.

Cylindrical containers shall be dropped on the top and bottom rims at diagonally opposite quadrants. The quadrant pairs shall be separated by approximately  $90^{\circ}$ . If a total of more than four rim drops is specified, the additional drops shall be on sections not previously dropped upon.

If the test specimen contains materials which are affected by temperature, the test shall be conducted while the container is stabilized at the extremes of temperature. Unless otherwise specified, half the total number of drops shall be made at  $-20^{\circ} \pm 5^{\circ}\text{F}$  and half shall be made at  $140^{\circ} \pm 5^{\circ}\text{F}$ .

7.           REPORT

7.1           Following the test a report shall be written which shall include the following:

7.1.1 A statement that the test was conducted in compliance with this procedure, or a description of the deviation from this procedure. Report all options selected and "otherwise specified" details that were followed as permitted in 2.1, 5.1, and 6.1.

7.1.2 Container dimensions, container structural details, type of materials used, spacing, size and type of fasteners, methods of closing and strapping, and the net and gross weights.

7.1.3 A description of the contents of the container including blocking, bracing, cushioning, or isolation system.

7.1.4 The results of the test, describing the final condition of both container and contents.

7.1.5 When the test is conducted to determine satisfactory performance of a container or pack, the report shall include a statement that the container or pack either attained or did not attain the specified performance. If not specified elsewhere, it is suggested that the following be cause for rejection:

- (a) Functional or physical damage to the contents.
- (b) Functional damage to the container.
- (c) Shock forces on the contents (or dummy load) which exceeds the established fragility of the contents.
- (d) Failure of a vapor or waterproof container to prevent vapor transmission or water leakage within specified limits.
- (e) Structural damage to the container which may result in damage to the contents during subsequent shipping, handling, or storage. Substantial spillage, exposure, or shifting of the contents are examples of such damage. Minor damage such as dents, paint chipping, or the crushing of wood members which do not impair the function of the container are not causes for rejection.

7.1.6 The report should include information, acquired through observation, to improve container or methods of packing.

## 8. NOTES

8.1 This test is meant to simulate the impacts of accidentally dropping a container on its edges. It is intended that the edgewise-drop test shall be used only on containers that are susceptible

to accidental edgewise drops. The edgewise-drop test was designed specifically for large and/or heavy shipping containers that are likely to be handled mechanically rather than manually. Details are given with the qualification, "unless otherwise specified," in paragraphs regarding:

- Definition of large containers (2.1).
- Conditioning of specimens (5.1).
- Number and height of drops (6.1).

8.2 When the edgewise-drop test is performed to evaluate the protection provided for the contents, the rigidity of a dummy load should closely approximate that of the actual contents for which the container was designed.

Table I. Height of rotational drops for containers of various sizes and weights 1/

Gross weight (within range limits)	Dimensions of any edge, height or width (within range limits)	Height of drops on edges	
		Level A Inches	Level B Inches
Pounds	Inches		
150 - 250	60 - 66	36	27
250 - 400	66 - 72	32	24
400 - 600	72 - 80	28	21
600 - 1000	80 - 95	24	18
1000 - 1500	95 - 114	20	16
1500 - 2000	114 - 144	17	14
2000 - 3000	Above 145 - No limit	15	12
Above - 3000		12	9

1/ Use the lowest drop height indicated by either gross weight or dimension. For example, a container having a gross weight of 440 lbs. and a maximum edge dimension of 95-5/8" shall be dropped 20 inches for Level A tests, or 16 inches for Level B tests.

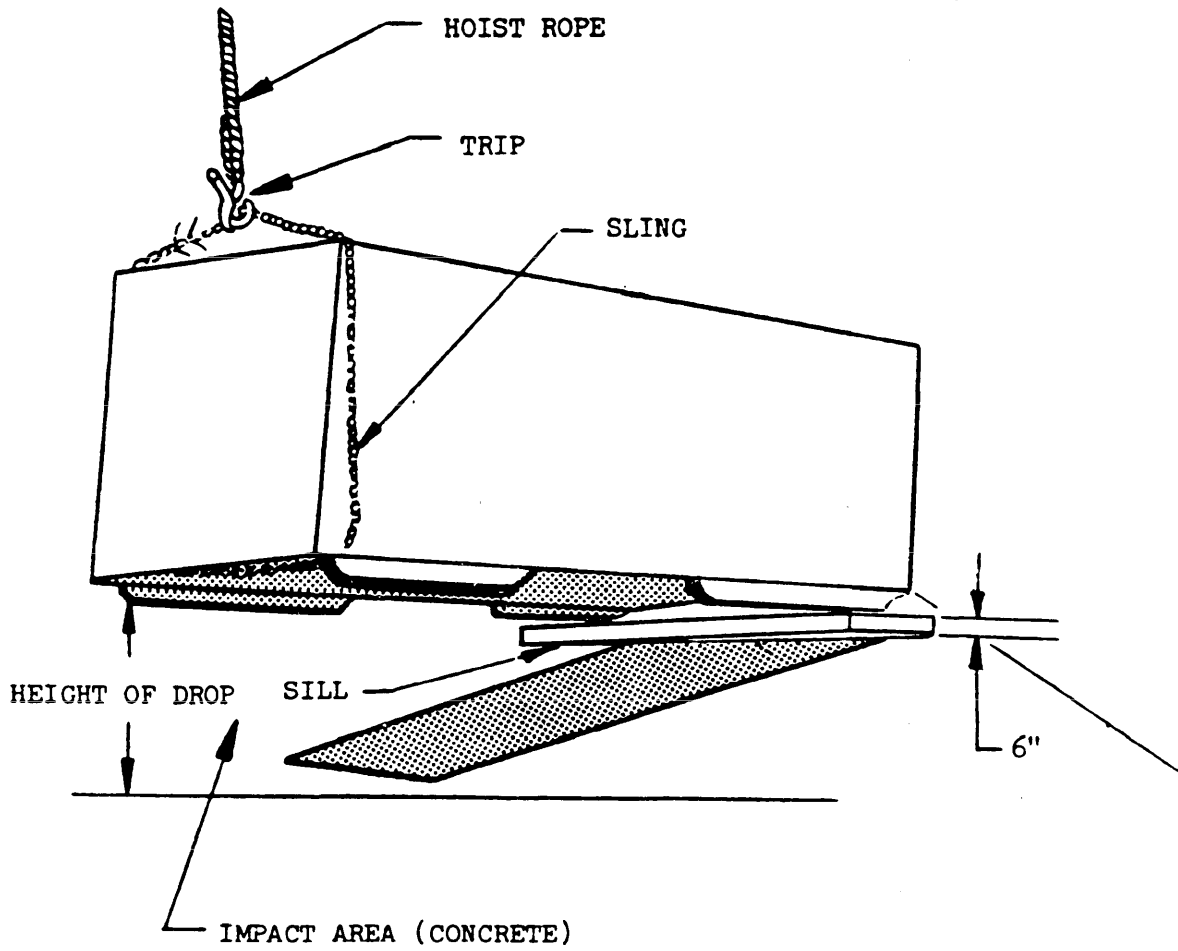

Figure 1. Edgewise drop (Rotational)

## LEAKS IN CONTAINERS

### 1. SCOPE

1.1 This test procedure provides eight common techniques for detecting leaks in containers.

1.2 For the leakage of air the following techniques are included:

- a. The "vacuum retention technique" in which air is evacuated from the container and it is vacuum sealed. Leakage is indicated by a loss of vacuum (6.1).
- b. Pneumatic pressure technique. The air in the container is pressurized and then the container is observed to detect leaks (6.2). When a container is found to leak, a portable ultrasonic leak detection technique may be used to locate the leak (6.2.5).
- c. Squeeze technique. A flexible container is sealed containing air at ambient conditions as for shipment, and then is squeezed to increase the internal air pressure as the container is observed to detect leaks (6.3).
- d. Hot water technique. A container is sealed containing air at ambient conditions as for shipment, and then immersed in hot water so that the rise in internal air temperature will produce a rise in air pressure as the container is observed for leaks (6.4).

1.3 For the leakage of water, or other contents indicated the following techniques are included:

- a. Submersion technique. The sealed container is submerged in various positions under water and subsequently opened and inspected for leakage (6.5). A variation is the "immersion technique" in which an open top container is inspected while immersed to a required depth.
- b. Simulated rainfall technique. The container closed as for shipment is subjected to water spray and subsequently opened and inspected for leakage (6.6).
- c. Hydraulic pressure technique. Internal pressure is utilized to force water or other liquids through any leaks and the container is inspected for such leakage (6.7).

- d. Static leak test. The container is filled with water, or other contents, and observed at rest in various positions to detect leakage of such contents (6.8).

## 2. DEFINITIONS

2.1 Leak. Any opening in a container that contrary to intention either lets contents escape or permits substances to enter.

2.2 Leakage. That which passes through a leak.

## 3. APPARATUS

3.1 Tests for air leaks require the following apparatus with the different techniques:

- a. Vacuum retention. A vacuum pump and pressure gage such as a manometer.
- b. Pneumatic pressure. A supply of compressed air, pressure gage and either a vessel in which the specimen can be submerged in water or a quantity of bubble-supporting liquid.
- c. Squeeze. Either a vessel in which the specimen can be submerged in water or a quantity of bubble-supporting liquid.
- d. Hot water. A vessel of hot water in which the specimen can be submerged and a means of maintaining the water temperature.

3.2 Tests for water leaks, or leaks of other contents, require the following apparatus with the different techniques:

- a. Submersion (or immersion). A vessel of water in which the specimen may be submerged or immersed.
- b. Simulated rainfall. Adjustable spray nozzles and a level area that will not trap standing water.
- c. Hydraulic pressure. A source of hydraulic or pneumatic pressure with gage and pressure regulator.
- d. Static leakage. Blocking as necessary to support the specimen in the various positions required.

3.3 Tests in which the specimen is submerged in water or tests, other than simulated rainfall, in which the water is a specified and diluted color solution, prepared in the following proportions:

1 g of Aerosol OT (or approved substantial equal),  
1 g of Erythrosin B (or approved substantial equal),  
98 ml of water.

Mix the solution and allow it to stand but for an occasional shaking for not less than four hours. One part of this solution shall be diluted with four parts of water before use.

#### 4. SPECIMEN

4.1 Unless otherwise specified, a specimen shall be one container (bag, envelope, pouch, can, drum, box or other) and its intended contents or simulated contents, packed and sealed as for shipment (6).

#### 5. CONDITIONING

5.1 Unless otherwise specified, no special conditioning of the specimen is required and it shall be at equilibrium with normal room conditions ( $70^{\circ} \pm 20^{\circ}\text{F}$ ).

#### 6. PROCEDURE

##### 6.1 Vacuum retention technique.

6.1.1 During the preparation of the specimen, make provisions for the connection of a tube to evacuated air, a gage to indicate any loss in vacuum pressure and an effective closing method of the container after the removal of the tube and gage. Such provisions may be a tube and gage sealed into openings at the corners of a seam of a flexible container or a drilled and tapped hole for a plug or a valve stem incorporated in a rigid container or other acceptable devices that can be either sealed or removed from the container without adverse effect.

6.1.2 Connect the vacuum pump to the specimen and evacuate the air until the specimen vacuum is attained. Unless otherwise specified, the vacuum pressure shall be  $9 \pm 1$  mm of mercury or  $5 \pm 1/2$  inches of water. The required vacuum may be drawn more than once to insure that equilibrium within the specimen is reached.

#### CAUTION

Vacuum pressure may cause damage to a flexible specimen or its contents, so use of this technique may be inappropriate for some designs.

6.1.3 When the specimen is evacuated to a constant specified pressure, stop evacuating air and record the vacuum pressure gage reading.

6.1.4 Ten minutes, unless otherwise specified, after the initial vacuum pressure reading, read and record the final pressure reading. Compute and record the loss in vacuum pressure.

## 6.2 Pneumatic pressure technique.

6.2.1 During preparation of the specimen, provisions shall be made for connecting a tube or clamp-in valve to the specimen. Either attach a pressure gage to the specimen or use a low pressure hand type tire gage to sense any loss in pressure. A tube or valve may be sealed into an opening at one end of a seam in a flexible container, a hole drilled and tapped with a plug, a "clamp-in valve" stem incorporated in a rigid container, or other methods which will permit removal and seal without adverse effects of the serviceability of the container.

6.2.1 Pressurize the specimen with air from compressed air supply. Gradually introduce air until either the prescribed pressure in the specimen is attained or leakage becomes apparent.

6.2.2 Evacuate the chamber to the specified vacuum pressure. Unless otherwise specified, the vacuum pressure (P) shall be calculated equal to the specified strength of the barrier seams (S) times pi ( $\pi$ ) divided by the sum of the two smaller dimensions (d1 and d2) of the package.

$$P = \frac{S \times \pi}{(d1 + d2)}$$

(For example, to test a package 10 by 6 by 4 inches enclosed in MIL-B-131 barrier material, the vacuum pressure shall be the specified strength of MIL-B-131 barrier seam (3-1/2 lb./in.) times pi (3.14) divided by the sum of the smaller dimensions (6 + 4 inches); that is, the vacuum pressure shall be 11/10 or 1.1 lb./sq. in. For other sizes other pressures shall be calculated in a similar manner or read from an appropriate curve.)

### CAUTION

Pneumatic pressure may cause explosive failure of weak specimens. The applied pressure should be no greater than necessary to reveal leaks.

6.2.3 When the specimen is pressurized to a constant specified pressure, read and record this initial pressure.

6.2.4 After 30 minutes, read and record the final gage pressure. If no change is noted between the initial and final gage pressure, the item is considered sealed. However, if any loss in pressure is detected, the leaks can be located by means of ultrasonic detector, submersion or bubble-supporting film methods; and repaired as required to seal the container.

6.2.5 An ultrasonic translator detector finds areas where leakage occurs. This technique can be used on all types and sizes of pressurized containers as a rapid means of "pinpointing" the source of leak.



6.2.6 If a water tank is available and the containers are relatively small, the specimens may be submerged 1 to 2 inches under water and observed for leakage with the specimen upright and with the specimen inverted. If the tank is not available or the container is too large, leakage can be detected by coating joints, castings connections, and other likely points with a bubble-supporting film, and observed for leakage.

6.3 Squeeze technique. (Applicable only to flexible specimens such as bags, envelopes, etc.)

6.3.1 During sealing of the specimen entrap as much air as possible within the specimen.

6.3.2 Either submerge the specimen 1 to 2 inches under water and, while squeezing the specimen to force air to the area under observation, observe all seams and surface for leakage; or coat all seams, joints, or other areas likely to leak with a bubble-supporting film and observe each for leaks while squeezing the specimen to force air to the area under observation. Record locations of leaks or state, "no leaks."

6.4 Hot water technique.

6.4.1 Any wax-dipped specimens shall be cooled to equilibrium at an initial temperature between 50° and 60°F.

6.4.2 Unless otherwise specified, submerge the specimen in water heated to a temperature at least 50°F above the initial temperature of the specimen (not over 110°F for wax-dipped specimens). While holding the specimen submerged with the uppermost surface covered by not more than 1 inch of water, observe for at least 15 seconds to detect leakage. The specimen shall be rotated and observed repeatedly until all of the specimen has been examined. Total time in hot water shall not exceed 8 minutes. Record the locations of any leaks or state, "no leaks."

6.5 Submersion (or immersion) techniques.

6.5.1 Unless otherwise specified, the specimen shall be submerged so that the uppermost surface is beneath the water surface not less than 1 inch or more than 2 inches for 1 hour or longer in water maintained at a temperature of not less than 40°F below the temperature at which the specimen is sealed. After submersion and before opening the specimen, carefully dry the outside of the specimen where the opening will be made. Then open the specimen.

6.5.2 When immersion of an open top container is required, the container shall be positioned in the water at the depth specified and held in such position for the period of time specified (see 8.2).

6.5.3 Inspect the inside for leakage. Record whether or not the specimen leaked and if possible, the locations of leaks.

6.6 Simulated rainfall technique.

METHOD 5009.3  
CHANGE NOTICE 3  
14 OCTOBER 1988

6.6.1 Unless otherwise specified, place the specimen upright on the level area and arrange the nozzles above so that water droplets will fall vertically in a uniform distribution onto the top of the specimen and the pavement around the specimen at a rate such that  $4 \pm 1$  inch of water per hour will accumulate in open top cylindrical cans positioned upright anywhere on the top of the container. Spray the specimen for a period of 4 hours. Several specimens may be sprayed simultaneously if they are spaced not less than 6 inches apart.

6.6.2 Before opening the specimen, carefully dry the outside of the specimen where the opening will be made. Open the specimen and inspect the inside, particularly any joints, connectors, and seams for leakage, or any adverse effect of spraying. Record whether or not the specimen leaked or suffered from spraying and, if possible, record the locations of any leaks.

6.7 Hydraulic pressure technique.

6.7.1 Before filling and sealing the specimen, a suitable leakproof connection for a pressure line shall be installed in the specimen.

6.7.2 Unless otherwise specified, fill the specimen with colored water (3.3) and connect either an air or water pressure line to the specimen.

6.7.3 Increase the pressure uniformly over a 10-second period to the test pressure and maintain it for the period of time specified. Unless otherwise specified, the pressure shall be 15 psi and the period shall be 5 minutes. Inspect the exterior of the specimen for leakage, particularly around joints and fastenings.

6.7.4 Record whether or not leakage was observed, and describe the locations of the leaks.

6.8 Static technique.

6.8.1 If the intended contents of the specimen are not fluid, unless otherwise specified, use the colored water (3.3) instead of the intended contents to fill the specimen, and close it as for shipment.

6.8.2 Unless otherwise specified, place the specimen in each of the following positions and leave it in each for a period of 15 minutes.

- Upright.
- Upside side.
- On one side (or one quadrant).
- On one end (or second quadrant).
- On other side (or third quadrant).
- On other side (or fourth quadrant).

6.8.3 Examine the specimen after each period and record location of any leakage or "no leakage."

## 7. REPORT

7.1 Immediately following each test the report (official record) of the facts pertinent to the test shall be completed, and shall include the following:

7.1.1 A statement that the test was conducted in compliance with this procedure or a description of the deviations from this procedure. Report all options selected and details of otherwise specified procedures that were followed as permitted in 4.1, 5.1 and 6.

7.1.2 Identification of the specimen and the specific material tested.

7.1.3 Results of the test. State whether or not leakage occurred, and if possible, report the location of each leak.

7.1.4 When the test is performed to check compliance with requirements, state that the specimen did or did not meet the requirements and give the source for the requirements.

7.1.5 When the test is conducted to evaluate or compare products or methods, the report shall include a statement of any observations that may lead to improvements.

## 8. NOTES

8.1 Selection of technique. The most appropriate technique will depend principally upon the construction, size and weight of the specimen and the information needed. If the specimen has removable caps or plugs or an air valve a pressure technique is appropriate to locate leaks. (The pneumatic pressure technique (6.2) might reveal smaller leaks than the hydraulic pressure technique (6.7), but hydraulic pressure is less hazardous than pneumatic pressure.) The hot water technique (6.4) is appropriate; or the squeeze technique (6.3) is appropriate for specimens constructed of flexible materials such as plastic film. The vacuum retention technique (6.1) does not specifically locate leaks and may not indicate the existence of tiny leaks in a large specimen. The submersion (or immersion) technique (6.5) for detecting water leakage is not as sensitive as the air leakage tests but it is appropriate to reveal whether or not water might lead into the specimen and, depending upon the duration of the test, gives some indication of the extent to which the materials used in the specimen are waterproof (remain unaffected by water). The simulated rainfall technique (6.6) is appropriate for the same purposes, but under other conditions particularly appropriate for very large

METHOD 5009.3  
CHANGE NOTICE 3  
14 OCTOBER 1988

specimens. The status technique (6.8) merely determines whether or not the contents of the specimen will leak out when the specimen rests in various positions, and may be appropriately used as a final test after all other tests on a specimen.

8.2 Details are given with the qualification, "unless otherwise specified," in the paragraph regarding:

Specimen (4.1).

Conditioning (5.1).

Techniques:

(6.1) Vacuum retention. Pressure (6.1.2), duration (6.1.4).

(6.2) Pneumatic pressure. Pressure (6.2.2).

(6.3) Squeeze technique.

(6.4) Hot water. Temperature (6.4.2).

(6.5) and (6.5.1). Submersion (or immersion). Time, depth, and temperature.

(6.6) Simulated rainfall. Specimen position, spray rate, period, and spacing of multiple specimens (6.6.1).

(6.7) Hydraulic pressure. Specimen contents (6.8.2), pressure and period (6.7.3).

(6.8) Static. Specimen contents (6.8.1), position and period (6.8.2).

## MECHANICAL HANDLING TEST

### 1. SCOPE

1.1 This test determines the ability of a package or container to withstand handling by mechanical handling equipment.

1.2 This test provides independent procedures for each of the following paragraphs:

6.2 Lifting and transporting by forklift truck.

6.3 Hoisting with slings.

6.4 Hoisting with grabs.

6.5 Pushing.

6.6 Towing.

6.7 Conveying.

1.3 These procedures do not include every conceivable mechanical handling hazard to a package. If the package must withstand other known hazards not represented by these procedures, other tests should be used. Conversely, any of these procedures not appropriate for a specific package should not be applied.

### 2. DEFINITIONS

2.1 Not applicable.

### 3. APPARATUS

3.1 Forklift handling.

3.1.1 A hard rubber tired forklift truck of sufficient capacity for the weight to be handled. Forks shall be adjusted to a spacing appropriate for the specimen under test, but not greater than 30 inches center to center.

3.1.2 Six nominal 1- by 4-inch boards longer than the width of the forklift truck.

3.2 Hoisting with slings.

3.2.1 A crane, hoist, or other arrangement of sufficient capacity for the weight to be lifted.

3.2.2 Slings of the lengths required to test the specimen (see 6.3).

3.3 Hoisting with grabs.

3.3.1 A crane, hoist, or other arrangement of sufficient capacity for the weight to be handled.

3.3.2 A pair of chain- or cable-operated gravity-type grabs. The length of the operating chain or cable shall be adjustable if necessary. The gripping surface of each grab shall be appropriate for the specimen being tested. For example, the surface for use on wood boxes or crates might be a flat plate with several conical teeth that with pressure will become embedded into the wood of the container and prevent slipping.

3.4 Pushing.

3.4.1 A vehicle of sufficient capacity to push the specimen.

3.5 Towing.

3.5.1 A vehicle of sufficient capacity to pull the specimen.

3.5.2 A towline of sufficient strength.

3.6 Conveying.

3.6.1 A level length of skate-wheel conveyor not less than 10 feet long and wide enough to handle the specimen. Width may be made up of more than one section of conveyor.

3.6.2 If necessary, equipment to move the specimen.

4. SPECIMENS

4.1 One container and its contents shall constitute a single specimen. The container shall be loaded for the test with the interior packing and the actual contents for which it was designed. If use of the actual contents is not practical, a dummy load shall be substituted to simulate such contents in weight distribution, shape, rigidity, and position in the container. The contents, or dummy load, shall be blocked, braced, and cushioned in place as for shipment.

5. CONDITIONING

5.1 Unless otherwise specified, no special conditioning of the test specimen shall be necessary.

6. PROCEDURE

6.1 Unless otherwise specified, handling provisions shall be tested as follows in the sequence given.

6.2 Lifting and transporting by forklift truck. The specimen shall be lifted clear of the ground by a forklift truck at one side of the specimen and transported on the forks in the level or the back-tilt position across a hard pavement for a distance not less than 100 feet. Parallel pairs of 1-inch boards spaced 54 inches apart shall be laid flatwise on the pavement across the path of the forklift truck. The first pair shall be placed squarely across the truck's path and centered 30 feet from the starting point; the second pair shall be laid 60 feet from the starting point at an angle of about  $60^{\circ}$  to the truck's path so the left wheel strikes first; and the third pair shall be laid 90 feet from the starting point at about  $75^{\circ}$  to the truck's path so the right wheel strikes first. If the specimen is less than 40 inches high and weighs less than 500 pounds, a load shall be superimposed on the specimen throughout the test to simulate stacking of the minimum number of specimens that will attain either a height not less than 80 inches or a weight not less than 1,000 pounds. (For example, if a specimen were 30 inches high and weighed 200 pounds, superimposed load would be required. A stack of three would measure 90 inches high, which is not less than 80, so the weight of two (400 pounds) would be superimposed on the test specimen. Similarly, if a test specimen were 15 inches high and weighed 300 pounds, a stack of four would weigh 1,200 pounds, which is not less than 1,000, so the weight of three (900 pounds) would be superimposed on the test specimen.) If the specimen is more than 36 inches wide and is stable on 36-inch-long forks, the forks shall extend only 36 inches under the specimen. The forklift truck carrying the specimen and superimposed load, if required, shall travel the 100 feet in about 23 seconds at a uniform speed (normal walking speed), and then shall be brought to a stop. The specimen shall be carefully observed during the traverse and while the forklift truck is at a stop for any damage, evidence of inadequacy, or deflection of the specimen that might cause damage or displacement of the contents. A record shall be made of the observations. The specimen with its superimposed load, if any, shall then be lowered to the ground. The forklift truck shall be moved from the side to the end of the specimen. The forks shall be run under the specimen as far as possible and then operated to lift the end 6 inches. Observe the specimen, particularly in the vicinity of the ends of the forks, and record observations. If the specimen can thus be lifted clear of the floor, transport it on the forks over the same 100-foot course, and record observations. If it cannot be thus lifted, report the length of forks used and state that the specimen could not be carried on the forklift truck at either end.

6.3 Hoisting with slings. If the specimen is less than 40 inches high and weighs less than 500 pounds, a load shall be superimposed on the specimen throughout the test to simulate stacking to not less than either a height of 80 inches or a weight of 1,000 pounds (see 6.2 for examples). Such superimposed load shall not contact the slings or lend reinforcement to the top structure of the package.

6.3.1 Undersling handling (fig. 1). Two slings without spreaders shall be placed around the specimen, each passing beneath the specimen, one near each end where indicated on the package and brought to a common point above the center of balance for attachment to the hoist. When no indication is provided, locate slings at outside end of rubbing strips if possible. If not possible, locate slings about midway between the center of balance and the ends. Lift the specimen and any superimposed load, and hold suspended for not less than 2 minutes. Observe carefully for any indications of inadequacies and let the specimen down again. Record observations.

6.3.2 Sling handling with attachments.

6.3.2.1 Attach slings to two hoisting attachment provisions (lift rings, eyes, lugs, or other devices), one on each side or each end, so that the specimen will remain upright when hoisted. The length of the slings shall be such that when lifting they form angles between  $20^{\circ}$  and  $25^{\circ}$  with a horizontal plane (fig. 2A). Lift the specimen clear of the floor and hold it suspended for not less than 2 minutes. Observe carefully for any indications of inadequacies of the specimen. Record observations and let the specimen down again. Repeat with other hoisting attachment provisions until each has been tested. If the specimen has only one attachment provision, attach only one sling to hold the specimen suspended for 2 minutes.

6.3.2.2 If more than one attachment point is provided, remove the superimposed load, if any, from the specimen. Attach one sling to one lifting attachment provision, and lift the specimen clear of the ground (fig 2B). Observe for any indications of inadequacies of the specimen. Record observations and lower the specimen to the ground. Repeat with each lifting attachment point provided on the specimen.

6.4 Hoisting with grabs (fig. 3). Align the grabs on opposite sides or ends of the specimen above its center of balance. Adjust the grab operating chain or cable so that while the specimen is suspended, the grab pressure normal to the surface of the container will be about 1.2 times the specimen's weight. (For an operating line extending continuously from the hoist attachment downward to a pulley on one grab, then horizontally to a pulley on the other grab and then upward to the hoist attachment, the required pressure will result when the inclined portion of the line forms  $45^{\circ}$  angles ( $\pm 5^{\circ}$ ) to the horizontal. For an operating line extending



METHOD 5011.1  
March 13, 1980

from one grab up to the hoist attachment and then down to the other grab (not horizontally between the grabs), the required pressure will result when the inclined portions of the line form angles of  $22-1/2^{\circ}$  ( $+2-1/2^{\circ}$ ) with a horizontal plane.) Connect the hoist to the lifting point of the grab operating line and slowly lift. If the specimen tilts excessively upon lifting, lower it and relocate the grabs and the lifting point, if necessary, to align with the center of gravity of the specimen. Hoist the specimen clear of the floor, hold it suspended for 2 minutes, and return it to the floor. Observe for any evidence of inadequacy or damage to the container, or deflection of the container that might cause damage or displacement of contents. A record shall be made of observations.

6.5 Pushing. Position the vehicle to abut the end of the specimen near the floor. If a forklift truck is used, the mast shall be vertical or at a slight back-tilt, and the forks shall extend beneath the specimen but shall not support it. Operate the truck to push the specimen along a hard, dry pavement a distance of 35 feet in about 85 seconds at a uniform speed, observing the specimen for any inadequacies or damage. Record observations. Move the vehicle to abut the side of the specimen near the floor and move the specimen sidewise over the same distance. Record observations.

6.5.1 When specified, the pushing test shall be repeated with one end of the container lifted off the ground about 6 inches by the tips of the forks inserted between the skids. The strength of the container structure as well as the skids, shall survive the test without failure or permanent deformation.

6.6 Towing. Attach a sling to the towline attachment fittings at one end, and connect with a towing vehicle at a height not greater than the fittings. If no fittings are provided, use a sling or gravity-type grabs at the base of the specimen for attaching the towline, or some other feasible arrangement may be devised. Operate the vehicle to tow the specimens along a hard, dry pavement a distance of 100 feet in about 23 seconds at a uniform speed (normal walking speed), observing the specimen for any inadequacies or damage. Record observations and the method of attaching the towline. Then reattach the towline and tow the specimen sidewise over the same distance. Record observations.

6.6.1 When specified, the towing test shall be repeated with one end of the container lifted off the ground about 6 inches by the tips of the forks inserted between the skids. The strength of the container structure, as well as the skids, shall survive the test without failure or permanent deformation.

6.7 Conveying.

6.7.1 Place the specimen lengthwise on the conveyor, and convey the specimen back and forth until the specified distance lengthwise is accumulated. Each movement shall be not less than the length of the container. Place the specimen crosswise on the conveyor and convey the specimen back and forth until the specified distance crosswise is accumulated. Observe and record any damage to the package or conveyor and record any difficulties in conveying the specimen.

6.7.2 Unless otherwise specified, the total conveyed distance shall be 1,000 feet lengthwise and another 1,000 feet crosswise.

6.8 Inspection after handling. Open the specimen and examine the inner surfaces of the container and inspect the contents for evidence of inadequacies or damage. Record observations.

7. REPORT

7.1 Following the test a report shall be written which shall include the following:

7.1.1 A statement that the test was conducted in compliance with this procedure, or a description of the deviation from this procedure. Report any "otherwise specified" details that were followed as permitted in 5.1, 6.1, and 6.7.2.

7.1.2 Dimensions of the container, its structural details, kind of materials, spacing, size and type of fasteners, methods of closing and strapping, details of handling provisions and the net and gross weights.

7.1.3 A description of the contents of the container including blocking, bracing, and cushioning or isolation system.

7.1.4 The results of the test, describing the final condition of both container and contents.

7.1.5 When the test is conducted to determine satisfactory performance of the container or pack, the report shall include a statement that the container or pack either attained or did not attain the specified performance. If not specified elsewhere, it is suggested that satisfactory performance shall consist of:

"When the container or package is subjected to the mechanical handling test, the contents (except a dummy load) shall show no functional or physical damage, and the container and packing shall show no functional damage. Damage to the exterior shipping container which is the result

of improper interior packaging, blocking, or bracing shall be cause for rejection. Structural failure of the exterior shipping container which would result in spilling of the contents or failure of the container in subsequent handling is cause for rejection. There shall be no evidence of a substantial amount of shifting of the contents within the exterior shipping container that would create conditions likely to cause damage during shipment, storage, and reshipment of the container. Minor container damage such as chipping of wood members, negligible dents, paint chipping, is not cause for rejection."

7.1.6 The report should include a statement of any observations that might help in improving the container or the methods of packing.

## 8. NOTES

8.1 This test procedure is intended to demonstrate the effects of handling a package by each of the several types of mechanical handling equipment. For example, the procedure for lifting and transporting by forklift truck demonstrates the effect of lifting or carrying from ends or sides, and the effect of carrying the specimen across simulated railroad tracks, thresholds or other irregularities. The test is intended also to evaluate provisions for the attachment of mechanical handling devices. Procedures are given independently for the various handling techniques so that a procedure for any technique inappropriate for a specific package may be excepted. For example, a container may have no lifting eyes or lugs for the attachment of slings; so only 6.3.1 which is a test for handling with an encircling sling should be applied and 6.3.2 which is a test for sling attachment should be excepted. References to this standard should list any of the methods of handling (6.2, forklifting; 6.3, sling handling; 6.4, grab handling; 6.5, pushing; 6.6, towing; and 6.7, conveying) that are to be excluded from the test procedures.

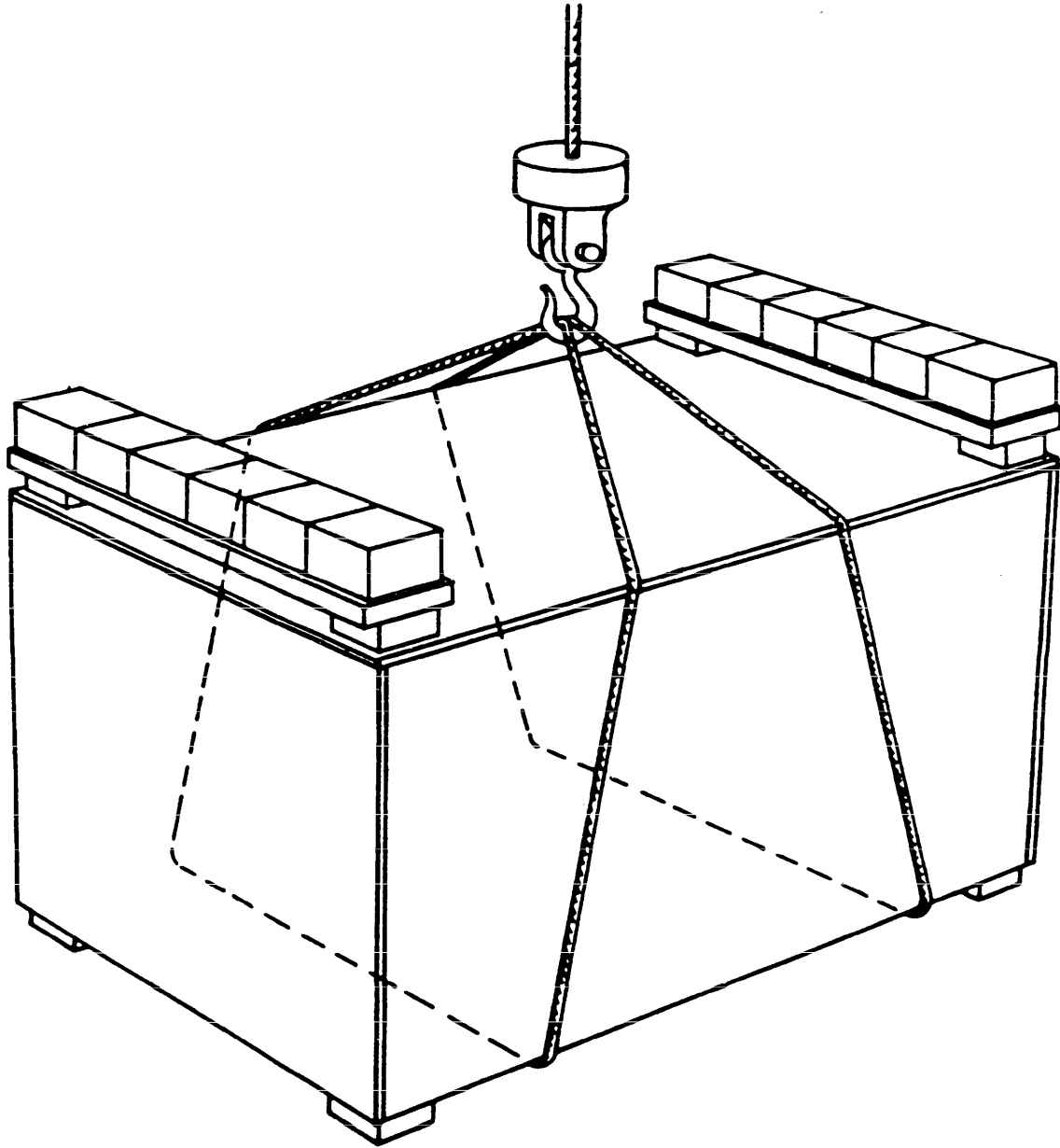

Figure 1. Slings placed around specimen with load superimposed

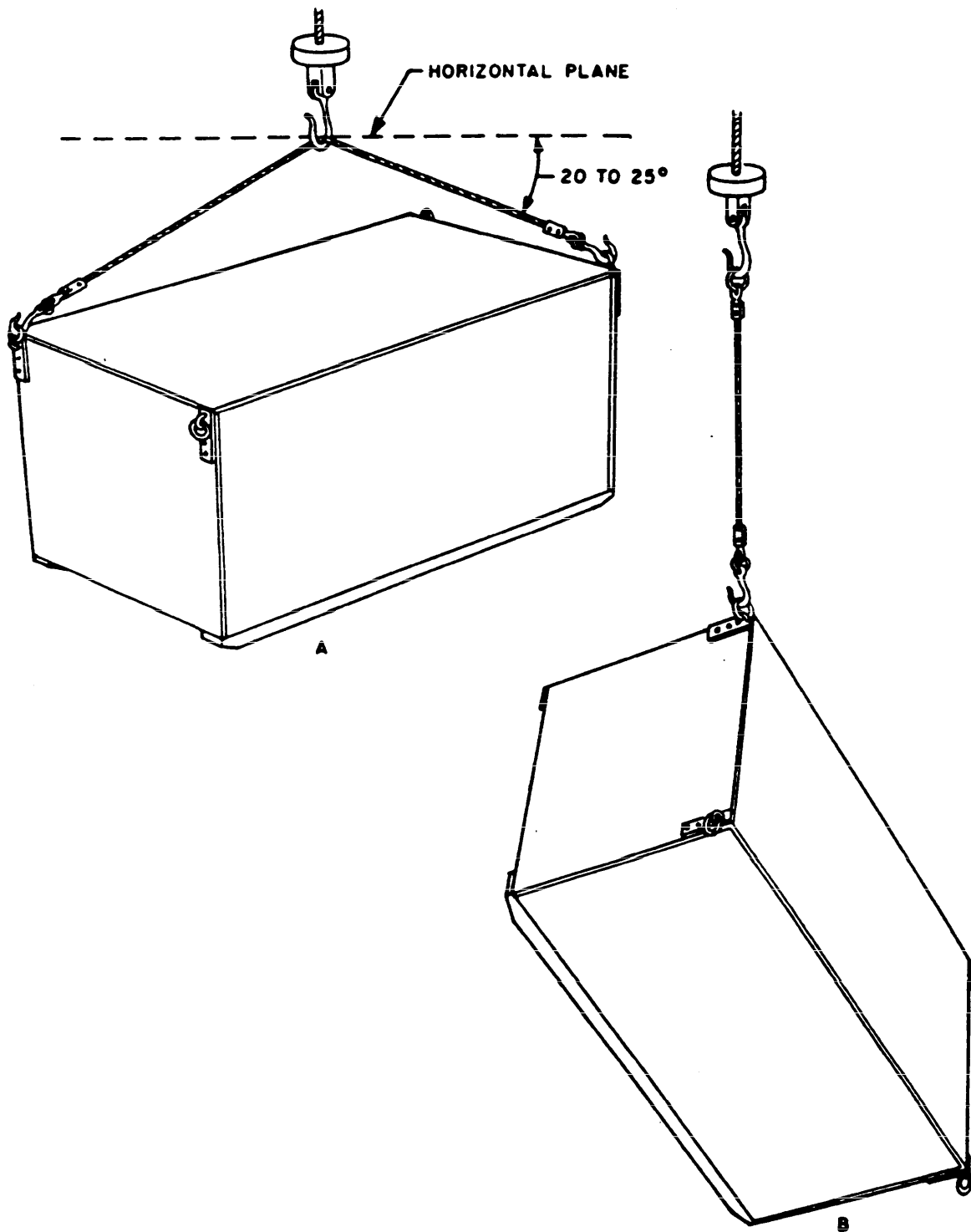

Figure 2. Hoisting with sling attachment provisions.

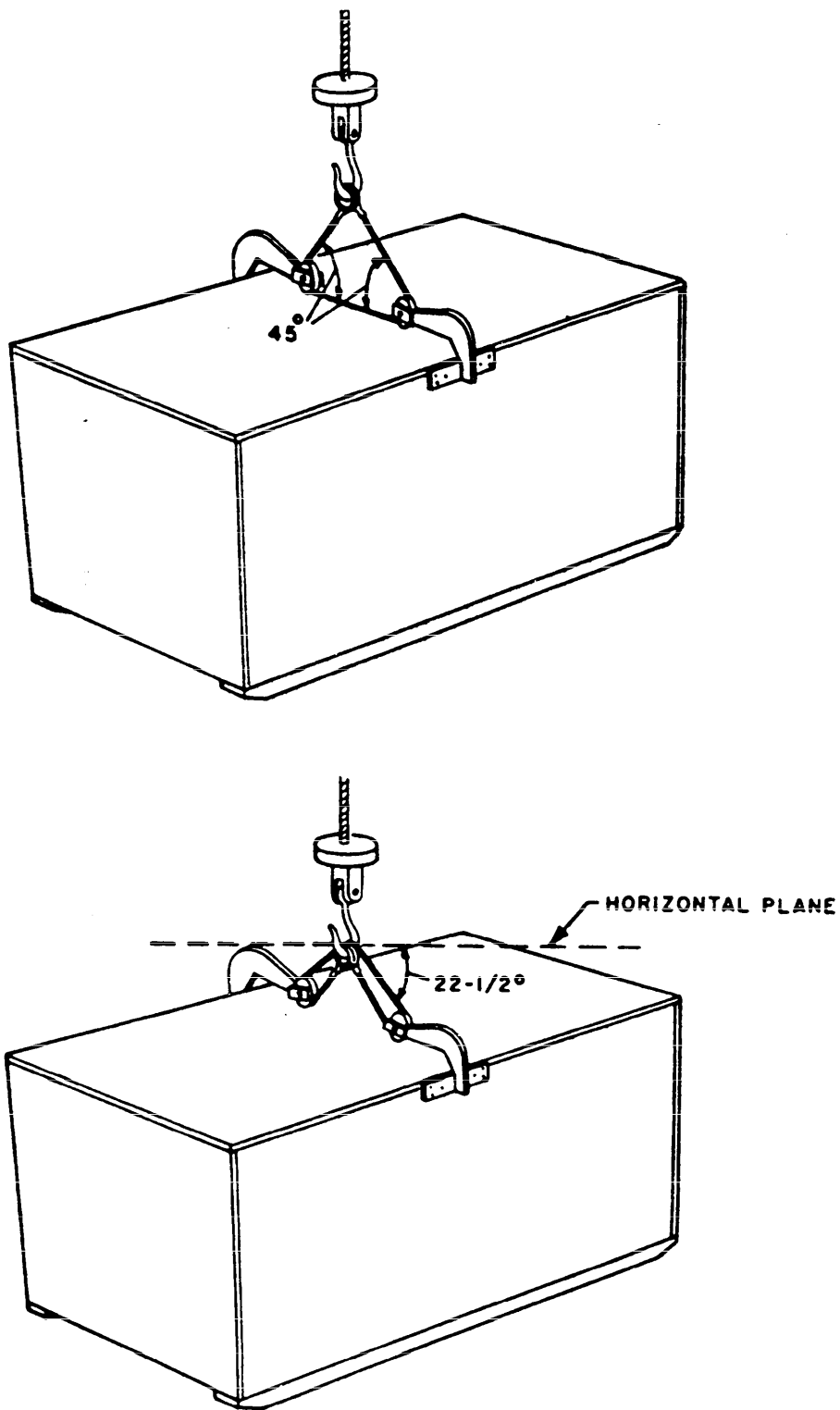

Figure 3. Hoisting with grabs.

## PENDULUM-IMPACT TEST

### 1. SCOPE

1.1 The following procedure is applicable for determining the ability of large shipping containers to resist horizontal impacts and for determining the ability of the packaging and packing methods to provide protection to the contents when the pack is impacted.

### 2. DEFINITION

2.1 For the purpose of this test, a large shipping container may be a box, case, crate or other container constructed of wood, metal or other material, or any combination of these for which ordinary box tests are not considered practical or adequate. Unless otherwise specified, large containers shall be considered as those which measure more than 60 inches on any edge or diameter, or those when loaded have gross weights in excess of 150 pounds.

### 3. APPARATUS

3.1 A pendulum-impact tester which consists of a platform suspended from a height at least 16 feet above the floor by four or more ropes, chains, or cables; and a bumper consisting of a flat, rigid concrete, or masonry wall, or other equally unyielding flat barrier. The bumper shall be 18 inches high, wide enough to make full contact with the container end, and shall have sufficient mass to resist the impacts without displacement. The impact surface shall be oriented perpendicular to the line of swing of the platform. The platform shall be large enough to support the container or pack, and when hanging free, shall have its top surface approximately 9 inches above the floor, and its leading edge at least 3 inches from the surface of the bumper. The suspension chains shall be vertical and parallel so that when the platform is pulled straight back it will raise uniformly but remain at all times horizontal and parallel to the floor.

### 4. SPECIMEN

4.1 One container and its contents shall constitute a single specimen. The container shall be loaded for the test with the interior packing and the actual contents for which it was designed. If use of the actual contents is not practical, a dummy load shall be substituted to simulate such contents in weight, shape, and position in the container. The contents, or dummy load, shall be blocked, braced, and cushioned in place as for shipment.

5.           CONDITIONING OF SPECIMEN

5.1           Unless otherwise specified, no special conditioning of the test specimen shall be necessary.

6.           PROCEDURE

6.1           The specimen shall be placed on the platform with the surface which is to be impacted projecting beyond the front end of the platform so that the specimen just touches the vertical surface of the bumper. The platform shall be pulled back so that the center of gravity of the pack is raised to the prescribed height, and then shall be released to swing freely so that the surface of the container impacts against the bumper (see figure 1). When the test is conducted to determine satisfactory performance of a container or pack and unless otherwise specified, each specimen shall be subjected to one impact to each side and each end that has a horizontal dimension of less than 9.5 feet. Unless otherwise specified, the vertical height of drop shall be 9 inches, which results in a velocity of 7 feet per second at impact.

6.2           A record shall be made of any changes or breaks in the container, such as apparent racking, nail pull, or broken parts and their locations. The packing (blocks, braces, cushions, or other devices) and the contents shall be examined carefully and a record made of their condition.

7.           REPORT

7.1           Following the test a report shall be written which shall include the following:

7.1.1         A statement that the test was conducted in compliance with this procedure, or a description of the deviation from this procedure. Report all options selected and "otherwise specified" details that were followed as permitted in 2.1, 5.1, and 6.1.

7.1.2         Dimensions of the container, its structural details, kind of materials, spacing, size and type of fasteners, methods of closing and strapping, and the net and gross weights.

7.1.3         A description of the contents of the container including blocking, bracing, and cushioning.

7.1.4         The results of the test, describing the final condition of both container and contents.



7.1.5 When the test is conducted to determine satisfactory performance of the container or pack, the report shall include a statement that the container or pack either attained or did not attain the specified, performance. If not specified elsewhere, it is suggested that satisfactory performance shall consist of:

"When subjected to the pendulum-impact test, the contents (except a dummy load) shall show no functional or physical damage, and the container and packing shall show no functional damage. Damage to the exterior shipping container which is the result of improper interior packaging, blocking, or bracing shall be cause for rejection. Structural damage to the exterior shipping container which would result in either spilling of the contents or failure of the container in subsequent handling is cause for rejection. There shall be no evidence of a substantial amount of shifting of the contents within the exterior shipping container that would create conditions likely to cause damage during shipment, storage, and reshipment of the container. Minor container damage such as chipping of wood members, dents, paint chipping, is not cause for rejection."

7.1.6 The report should include a statement of any observations that might help in improving the container or the methods of packing.

## 8. NOTES

8.1 This test is meant to simulate severe railroad humping or other accidental handling impacts. It is intended that the pendulum-impact test shall be used only on containers that are susceptible to accidental end impacts. The pendulum impact was designed specifically for large and/or heavy shipping containers that are likely to be handled mechanically rather than manually. Details are given with the qualification, "unless otherwise specified," in paragraphs regarding:

Definition of large containers (2.1).  
Conditioning of specimens (5.1).  
Number and height of drops (6.1).

8.2 When the pendulum-impact test is performed to evaluate the protection provided for the contents, the rigidity of a dummy load should closely approximate that of the actual contents for which the pack was designed.

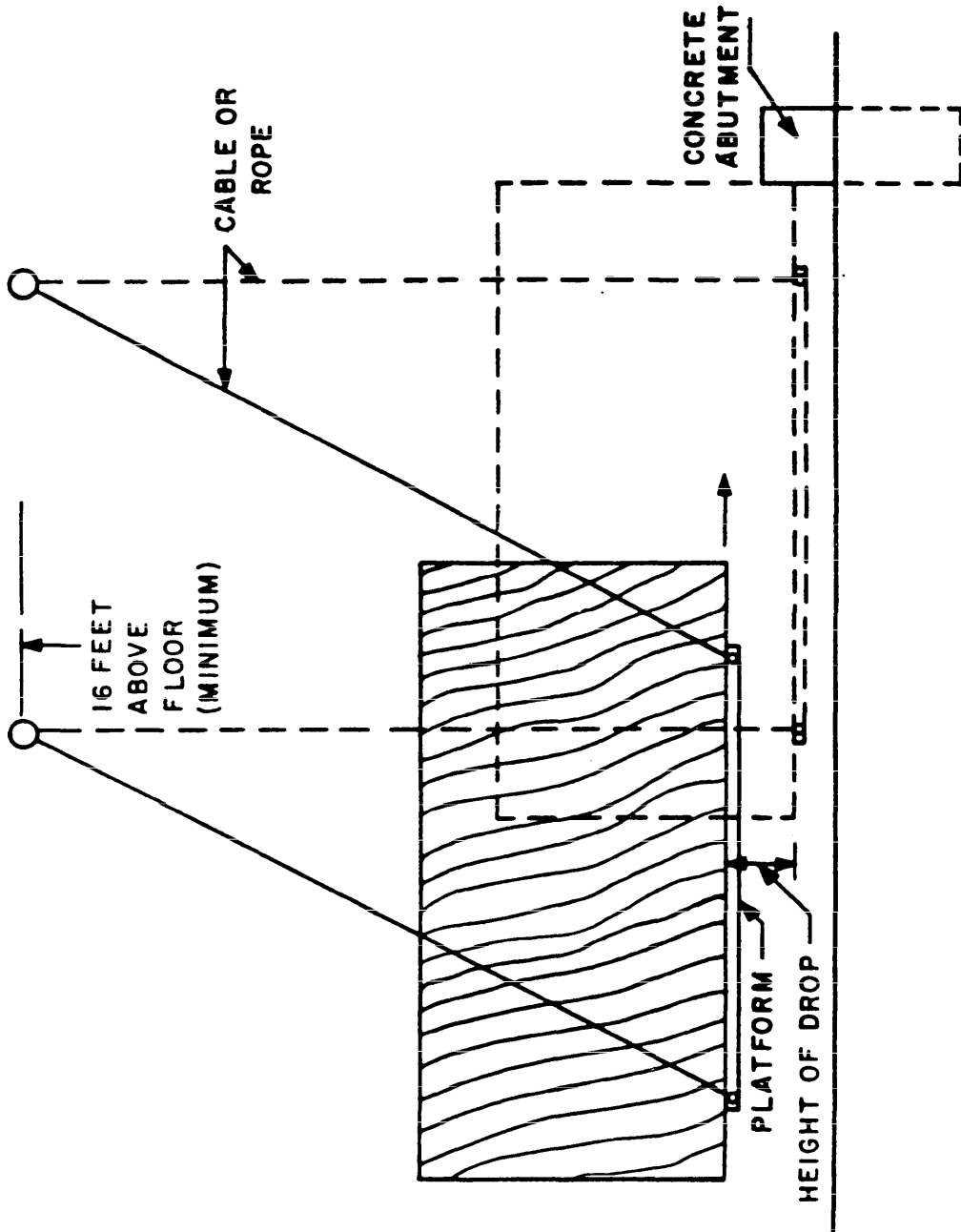

Figure 1. Pendulum-impact test

## ROLLOVER TEST

### 1. SCOPE

1.1 This procedure indicates the ability of a package to withstand rolling completely over from base to one side, to top, to other side, and onto the base again.

1.2 This procedure is applicable to packages too large for testing in the revolving drum apparatus, but light enough or of proportions so that the package might possibly be rolled over during rough handling.

### 2. DEFINITIONS

2.1 Not applicable.

### 3. APPARATUS

3.1 A sufficient area of level, rigid pavement or similarly unyielding surface.

3.2 A forklift truck, or sufficient manpower, to topple the package for each impact.

### 4. SPECIMENS

4.1 One container and its contents shall constitute a single specimen. The container shall be loaded for the test with the interior packing and the actual contents for which it was designed. If use of the actual contents is not practical, a dummy load shall be substituted to simulate such contents in weight, shape, and position in the container. The contents, or dummy load, shall be blocked, braced, and cushioned in place as for shipment.

### 5. CONDITIONING

5.1 Unless otherwise specified, no conditioning of the specimen is required.

### 6. PROCEDURE

6.1 The specimen shall be placed in its normal upright position on the pavement. The specimen shall then be slowly tipped toward one side until it topples and falls by its own weight onto the side. Then topple the specimen so that it falls onto its top. Again topple the specimen so it falls onto its other side, and finally topple so it falls onto its base. Observe the container and record any evidence of inadequacies or damage that would impair serviceability of the container.

6.2 Open the container and examine the blocking, bracing, cushioning, and preservation. Record any evidence of inadequacies or damage that would impair serviceability of the package.

6.3 If the specimen included the item for which the package was designed, determine and record whether or not the item sustained damage, describe any damage, and record any apparent reasons why damage occurred.

## 7. REPORT

7.1 Immediately following each test the report (official record) of the facts pertinent to the test shall be completed, and shall include the following:

7.1.1 A statement that the test was conducted in compliance with this procedure, or a description of the deviations from this procedure. Report all options selected and details of otherwise specified procedure that were followed as permitted in 4.1, 5.1, and 6.3 (give method of determining damage to item).

7.1.2 Identification of the item and the specific package tested.

7.1.3 Results of the test. Either report the evidence of inadequacies and describe damage or state, "no evidence of inadequacies and no damage."

7.1.4 When the test is performed to check compliance with requirements, state that the specimen did or did not meet the requirements and give the source for the requirements.

7.1.5 When the test is conducted to evaluate or compare products or methods, the report shall include a statement of any observations that may lead to improvements.

## 8. NOTES

8.1 Details are given with the qualification, "unless otherwise specified," in the paragraph regarding conditioning (5.1).

8.2 This procedure should not be used for items too heavy to anticipate rollover in handling. For relatively high, narrow packages the tipover test may be more appropriate than this rollover test.

SUPERIMPOSED-LOAD TEST (STACKABILITY, WITH DUNNAGE)

1. SCOPE

1.1 The following procedure is applicable for determining the ability of shipping containers to resist loads such as imposed on the bottom container of a stack of similar containers in storage, or on a container supporting top dunnage and superimposed lading; and for determining the ability of the packaging and packing methods to provide protection to the contents when the pack is so loaded.

2. DEFINITIONS

2.1 Top dunnage. Pieces of relatively stiff material, usually wood, laid across the top of a container or layer of containers to carry the weight of superimposed lading to the sides of the containers.

2.2 The levels of packing to be provided for any item or contents are dependent upon the handling, shipping, and storage conditions which the container or pack may be expected to encounter. For the purpose of this standard, the levels of packing shall be defined as:

2.2.1 Level A. Level A is the degree of preservation or packing required for protection of materiel against the most severe conditions known or anticipated to be encountered during shipment, handling, and storage. Preservation and packaging designated Level A will be designed to protect materiel against direct exposure to extremes of climate, terrain, operational and transportation environments without protection other than that provided by the pack. The conditions to be considered include, but are not limited to:

- (a) Multiple handling during transportation and intransit storage from point of origin to ultimate user.
- (b) Shock, vibration and static loading during shipment.
- (c) Loading on shipdeck, transfer at sea, helicopter delivery and offshore or over-the-beach discharge, to ultimate user.
- (d) Environmental exposure during shipment or during intransit operations where port and warehouse facilities are limited or non-existent.
- (e) Extended open storage in all climatic zones.
- (f) Static loads imposed by stacking.

2.2.2 Level B. Level B is the degree of preservation or packing required for protection of materiel under known favorable conditions during shipment, handling and storage. Preservation and packing designated Level B will be designed to protect materiel against physical damage and deterioration during favorable conditions of shipment, handling and storage. The conditions to be considered include but are not limited to:

- (a) Multiple handling during transportation and intransit storage.
- (b) Shock, vibration and static loading of shipment worldwide by truck, rail, aircraft, or ocean transport.
- (c) Favorable warehouse environment for extended periods.
- (d) Environmental exposure during shipment and intransit transfers, excluding deck loading and offshore cargo discharge.
- (e) Stacking and supporting superimposed loads during shipment and extended storage.

### 3. APPARATUS

3.1 In conducting the top superimposed-load test, any convenient method may be used for placing the load on top of the container; such as a hoist, a block and tackle, or by hand. The load may also be applied and maintained by means of a testing machine.

### 4. SPECIMEN

4.1 One container and its contents shall constitute a single specimen. The container shall be loaded for the test with the interior packing and the actual contents for which it was designed. If use of the actual contents is not practical, a dummy load shall be substituted to simulate such contents in weight, shape, and position in the container. The contents, or dummy load, shall be blocked, braced, and cushioned in place as for shipment.

### 5. CONDITIONING OF SPECIMEN

5.1 Unless otherwise specified, no special conditioning of the test specimen shall be necessary.

6. PROCEDURE

6.1 The specimen shall be placed on its bottom on a flat, level, rigid floor. A prescribed load shall be applied to the top of the container in a manner simulating the effect of similar containers being stacked on top, and the load shall be allowed to remain in place for a prescribed period of time. The bearing of the top superimposed load shall be on the same load-bearing areas that the skids, rubbing strips, or other base members would make on the container top. When the test is conducted to determine satisfactory performance of a container, and unless otherwise specified, the prescribed period of time shall be, 1 hour and the prescribed load shall be as follows:

$$W = P \times \frac{16-H}{H} \times S \text{ or } 200 \times A \times S;$$

whichever is larger

where:

W = Prescribed top superimposed load, in pounds.

P = Weight of the loaded container, in pounds.

H = Height of container, in feet.

A = Area of top of container, in square feet.

S = 2.0 for Level A packing.

S = 1.5 for Level B packing.

6.1.1 If the principal support structure is a plastic or other non-metallic material with a tendency to creep or deteriorate when exposed to elevated temperatures or very humid conditions, the test shall be repeated at a temperature of  $120^{\circ} + 5^{\circ}\text{F}$  and 90 percent relative humidity for a period of 168 hours. In this latter case the constant "S" shall be 1.0.

6.2 A record shall be made of any changes or breaks in the container, such as apparent buckling or failure of members in the sides or ends. Any vertical deflections of the sides and ends shall be measured from taut horizontal string lines stretched between nails in the top corners of each side and end. In addition, bulging of the side and end panels shall be measured from a vertical straight edge (see fig. 1). Observations shall be made to determine if the distortions were sufficient to damage or dislodge the interior packing or contents.

7. REPORT

7.1 Following the tests a report shall be written which shall include the following:

7.1.1 A statement that the test was conducted in compliance with this procedure, or a description of the deviation from this procedure. Report all options selected and "otherwise specified" details that were followed as permitted in 5.1 and 6.1.

7.1.2 Dimensions of the container, its structural details, kind of materials, spacing, size and type of fasteners, methods of closing and strapping, and the net and gross weights.

7.1.3 A description of the contents of the container including blocking, bracing, and cushioning or isolation system, and a record of the deflections under load.

7.1.4 The results of the test, describing the final condition of both container and contents.

7.1.5 When the test is conducted to determine satisfactory performance of a container or pack, the report shall include a statement that the container or pack either attained or did not attain the specified performance. If not specified elsewhere, it is suggested that satisfactory performance shall consist of:

"When subjected to the top superimposed-load test, the contents (except a dummy load) shall show no functional or physical damage, and the container and packing shall show no functional damage. Damage to the exterior shipping container which is the result of improper interior packaging, blocking, or bracing shall be cause for rejection. Structural damage to the exterior shipping container which would result in either spilling of the contents or failure of the container in subsequent handling is cause for rejection. There shall be no evidence of a substantial amount of shifting of the interior packing or the contents within the exterior shipping container that would create conditions likely to cause damage during shipment, storage, and reshipment of the container."

7.1.6 The report shall include a statement of any observations that might help in improving the container or the methods of packing.

8. NOTES

8.1 This test is meant to simulate the top superimposed loads imposed by stacking of like containers as in storage or by stowing lading upon top dunnage in the hold of a ship. It is intended that this



test shall be used only on containers that are likely to be stressed in this manner. Details are given with the qualification, "unless otherwise specified", in paragraphs regarding:

Conditioning of specimens (5.1).  
Load and duration of load (6.1).

8.2 Although the recommended period of time for the top superimposed-load test is only 1 hour, the use of the factor for Levels A and B packing insures a load-carrying capacity adequate for longtime loading and an occasional application of impact loads.

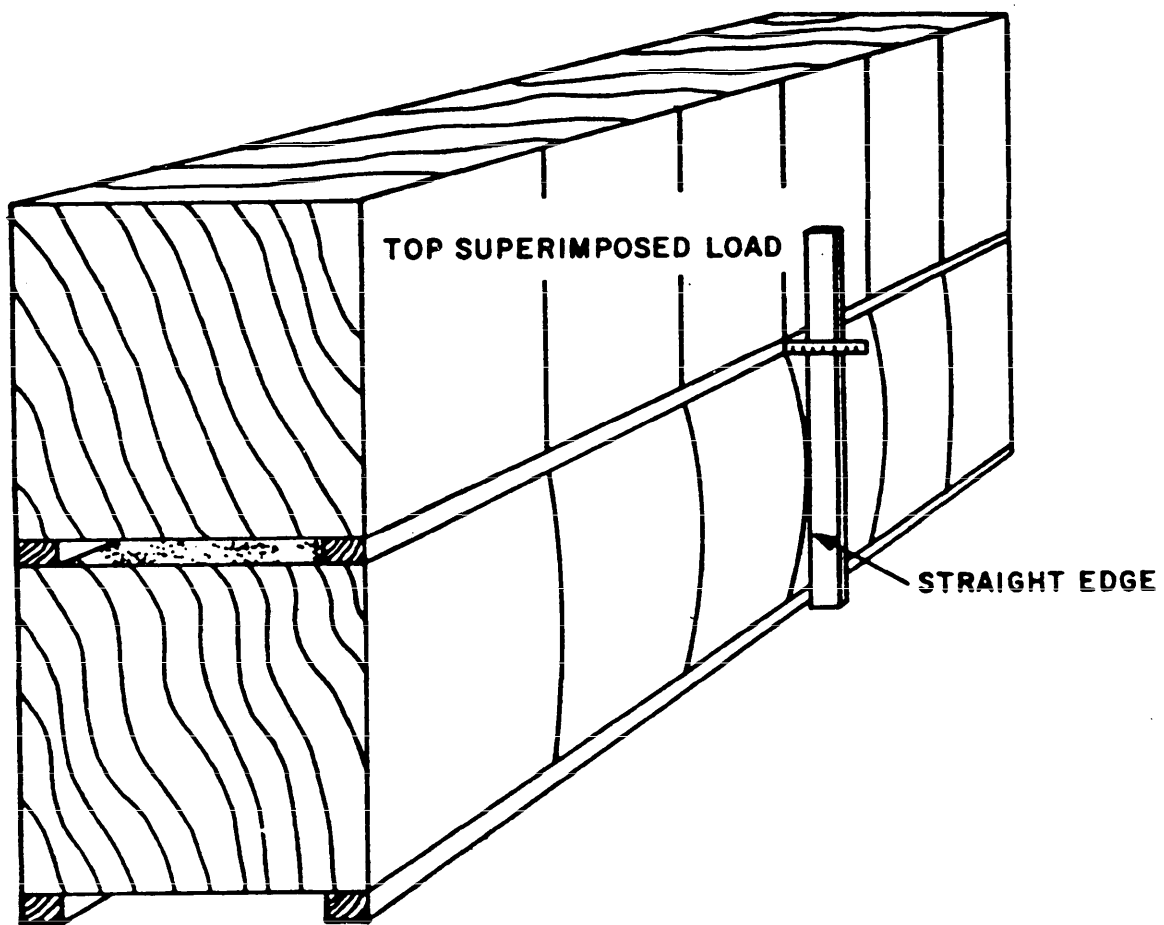

Figure 1. Top superimposed load test.

**SUPERIMPOSED-LOAD TEST  
(UNIFORMLY DISTRIBUTED, WITHOUT DUNNAGE)**

1. SCOPE

1.1 The following procedure is applicable for determining ability of shipping containers to resist loads superimposed on their tops as imposed by piling without top dunnage many small, heavy packages on a container, and for determining the ability of the packaging and packing methods to provide protection to the contents when the pack is so loaded.

2. DEFINITIONS

2.1 Top dunnage. Pieces of relatively stiff material, usually wood, laid across the top of a container or layer of containers to carry the weight of superimposed lading to the sides of the containers.

2.2 The levels of packing to be provided for any item or contents are dependent upon the handling, shipping, and storage conditions which the container or pack may be expected to encounter. For the purpose of this standard, the levels of packing shall be defined as follows:

2.2.1 Level A. Adequate packing to provide protection against handling, shipping, and storage hazards during worldwide distribution.

2.2.2 Level B. Adequate packing to provide protection against handling, shipping, and storage hazards, that may occur during multiple domestic shipments or which are known to be less hazardous than those for level A.

3. APPARATUS

3.1 In conducting the top superimposed-load test, any convenient method may be used for placing the load on top of the container; such as a hoist, a block and tackle, or by hand. A sufficient quantity of weights not greater than 10 by 10 inches in outside length and width shall be provided. Weights may be boxes loaded with lead or other material.

4. SPECIMEN

4.1 One container and its contents shall constitute a single specimen. The container shall be loaded for the test with the interior packing and the actual contents for which it was designed. If use of the actual contents is not practical, a dummy load shall be substituted to simulate such contents in weight, shape, and position in the container. The contents, or dummy load, shall be blocked, braced, and cushioned in place as for shipment.

5. CONDITIONING OF SPECIMEN

5.1 Unless otherwise specified, no special conditioning of the test specimen shall be necessary.

6. PROCEDURE

6.1 The specimen shall be placed on its bottom on a flat, level rigid floor. Weights shall be placed on top of the container in a symmetrical pattern approximating uniform loading, so that they do not extend over the sides or ends of the top surface. There shall be one weight to each 1-foot square of top surface and each weight shall be whatever is necessary to attain the prescribed load for the top area. The load shall be allowed to remain in place for a prescribed period of time. When the test is conducted to determine satisfactory performance of a container and unless otherwise specified, the prescribed period of time of loading shall be 1 hour and the prescribed load shall be as follows:

$W = \text{Top area in square feet} \times 50 \times S$ , where:

$W = \text{Prescribed top superimposed load, in pounds.}$

$S = 2.0$  for Level A packing.

$S = 1.5$  for Level B packing.

6.2 Measurements of distortion shall be made and recorded immediately before the load is removed, and of any changes or breaks in the container, such as apparent buckling or failure of members in the tops, sides, or ends. Any vertical deflections of the sides, and ends shall be measured from taut horizontal string lines stretched between nails in the top corners of each side and end. In addition, bulging of the side and end panels shall be measured from a vertical straightedge. The cupping of the top shall be measured similarly by using a straightedge across the

top at midlength of the specimen (see figure 1). Observations shall also be made and recorded to determine if the distortions are sufficient to damage or dislodge any portion of the container, the interior packing or contents. After removal of the load, the extent of recovery from distortions shall be observed and recorded.

## 7. REPORT

7.1 Following the test a report shall be written which shall include the following:

7.1.1 A statement that the test was conducted in compliance with this procedure, or a description of the deviation from this procedure. Report all options selected and "otherwise specified" details that were followed as permitted in 5.1 and 6.1.

7.1.2 Dimensions of the container, its structural details, kind of materials, spacing, size and type of fasteners, methods of closing and strapping, and the net and gross weights.

7.1.3 A description of the contents of the container including blocking, bracing, and cushioning.

7.1.4 The results of the test, describing the final conditions of both container and contents, and a record of the deflections under load.

7.1.5 When the test is conducted to determine satisfactory performance of a container or pack, the report shall include a statement that the container or pack either attained or did not attain the specified performance. If not specified elsewhere, it is suggested that satisfactory performance shall consist of:

"When subjected to the top superimposed-load test, the contents (except a dummy load) shall show no functional or physical damage, and the container and packing shall show no functional damage. Damage to the exterior shipping container which is the result of improper interior packaging, blocking, or bracing shall be cause for rejection. Structural damage to the exterior shipping container which would result in either spilling of the contents or failure of the container in subsequent handling is cause for rejection. There shall be no evidence of a substantial amount of shifting of the contents within the exterior shipping container that would create conditions likely to cause damage during shipment, storage and reshipment of the container."

7.1.6 The report should include a statement of any observations that might help in improving the container or the methods of packing.

8. NOTES

8.1 This test is meant to simulate top superimposed loads as imposed by piling without dunnage many small, heavy packages on a container. It is intended that this test shall be used only on containers that are likely to be stressed in this manner. Details are given with the qualification, "unless otherwise specified," in paragraphs regarding:

Conditioning of specimens (5.1).

Load and duration of load (6.1).

8.2 Although the recommended period of time for the top superimposed-load test is only 1 hour, the use of the factor for Levels A and B packing insures a load-carrying capacity adequate for longtime loading and an occasional application of impact loads.

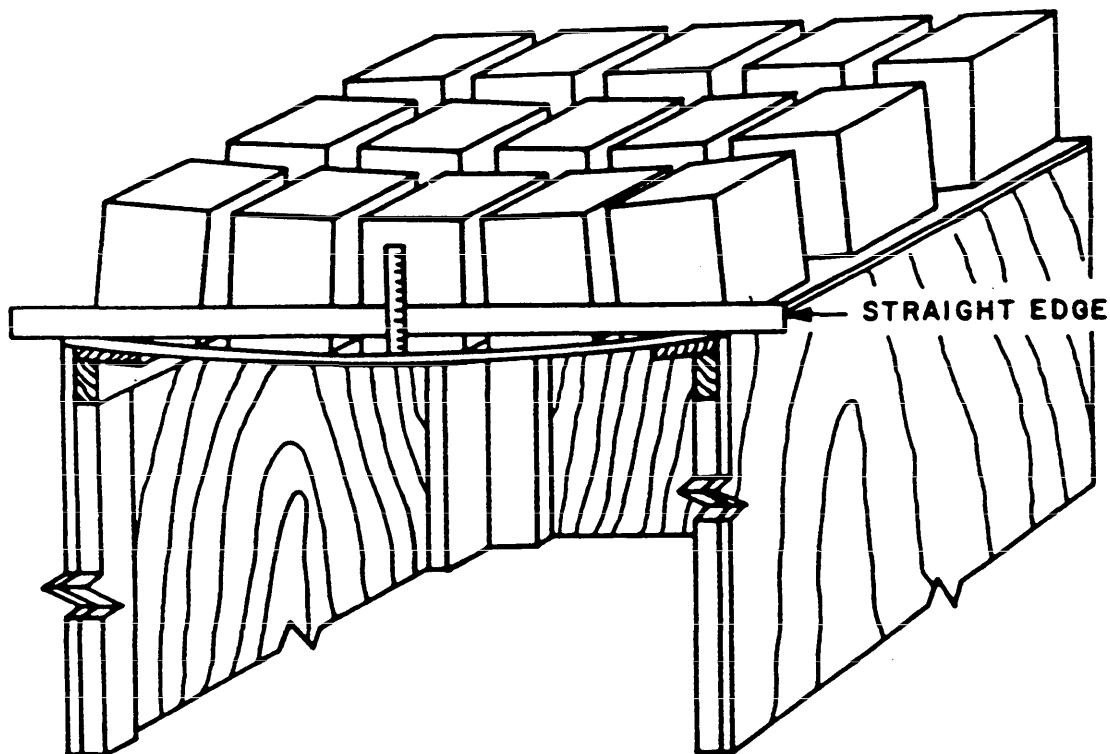

Figure 1. Top superimposed load test.

TIPOVER TEST

1. SCOPE

1.1 The following procedure is applicable for determining the ability of large shipping containers to resist the impacts of being tipped over, and for determining the ability of the packaging and packing methods to provide protection to the contents, when the pack is tipped over. Unless otherwise specified, containers having widths greater than one-fourth the height shall not be tested in this manner.

2. DEFINITION

2.1 For the purpose of this test, a large shipping container may be a box, case, crate, or other container constructed of wood, metal, or other material, or any combination of these for which ordinary box tests are not considered practical or adequate. Unless otherwise specified, large containers shall be considered as those which measure more than 60 inches on any edge or diameter, or those when loaded have gross weights in excess of 150 pounds.

3. APPARATUS

3.1 In making the tipover test, the container may be handled with any convenient equipment, such as a forklift truck, a hoist, a block and tackle, or by hand. A smooth, level, concrete slab, pavement, or similarly unyielding surface shall be available upon which to perform the tipover test.

4. SPECIMEN

4.1 One container and its contents shall constitute a single specimen. The container shall be loaded for the test with the interior packing and the actual contents for which it was designed. If use of the actual contents is not practical, a dummy load shall be substituted to simulate such contents in weight, shape, and position in the container. The contents, or dummy load, shall be blocked, braced, and cushioned in place as for shipment.

5. CONDITIONING OF SPECIMEN

5.1 Unless otherwise specified, no special conditioning of the test specimen shall be necessary.

6. PROCEDURE

6.1 The specimen shall be placed on its bottom and slowly tipped until it falls freely (by its own weight) on its side to a smooth, level, concrete slab or similarly unyielding surface. Unless otherwise specified, two of these tipovers shall be made, one on each side or 180 degrees apart on a cylinder. A record shall be made of any changes or breaks in the container, such as apparent racking, nail pull, or broken parts and their locations. The packing (blocks, braces, cushions, or other devices) and the contents shall be examined carefully and a record made of their condition.

7. REPORT

7.1 Following the test a report shall be written which shall include the following:

7.1.1 A statement that the test was conducted in compliance with this procedure, or a description of the deviation from this procedure. Report all options selected and "otherwise specified" details that were followed as permitted in 1.1, 2.1, 5.1, and 6.1.

7.1.2 Dimensions of the container, its structural detail, kind of material, spacing, size and type of fasteners, methods of closing and strapping, and the net and gross weights.

7.1.3 A description of the contents of the container including blocking, bracing, and cushioning.

7.1.4 The results of the test, describing the final condition of both container and contents.

7.1.5 When the test is conducted to determine satisfactory performance of a container or pack, the report shall include a statement that the container or pack either attained or did not attain the specified performance. If not specified elsewhere, it is suggested that satisfactory performance shall consist of:

"When subjected to the tipover test, the contents (except a dummy load) shall show no functional or physical damage, and the container and packing shall show no functional damage. Damage to the exterior shipping container which is the result of improper interior packaging, blocking, or bracing shall be cause for rejection. Structural damage to the exterior shipping container which would result in either spilling of the contents or failure of the container in subsequent handling is cause for rejection. There shall be no evidence of a substantial amount of shifting of the contents within the exterior shipping container that would create conditions likely to cause damage during shipment, storage, and reshipment of the container. Minor container damage such as chipping of wood members, dents, paint chipping, is not cause for rejection."



7.1.6 The report should include a statement of any observations that might help in improving the container or the methods of packing.

8. NOTES

8.1 This test is meant to simulate the impacts of accidentally tipping over a container. It is intended that the tipover test shall be used only on containers that are susceptible to accidental tipovers. Details are given with the qualification, "unless otherwise specified," in paragraphs regarding:

Scope - excluded containers (1.1)

Definition of large containers (2.1).

Conditioning of specimens (5.1).

Number and direction of tipover (6.1).

8.2 When the tipover test is performed to evaluate the protection provided for the contents, the rigidity of a dummy load should closely approximate that of the actual contents for which the pack was designed.



## VIBRATION (REPETITIVE SHOCK) TEST

### 1. SCOPE

1.1. This procedure is intended to indicate whether or not a package is adequate to prevent damage to either the packaging or the contents when the package is tested unattached on the platform of a package vibration testing machine at frequencies below 5 "Hertz" (Hz). Either the package bounces on the platform and receives repetitive shocks and vibration of an indiscrete and variable nature; or the package does not leave the platform. Shocks applied to the package excite each component at its own natural frequency, but when the package does not leave the platform only those components that vibrate in resonance with the platform vibration are excited.

1.2 This procedure is useful to predict whether or not such vibrations in transportation are likely to cause damage to the packaging or contents when the shipment is not securely tied down to the floor of the vehicle. Supplementary functional tests of the package contents may be necessary to evaluate functional damage. The procedure is not intended for the development of design parameters for shock and vibration isolation systems.

### 2. DEFINITIONS

2.1 Vibration. The continuous oscillation of an element or body relative to a suitable reference point.

2.2 Shock. A blow, impact, collision, jar, or similar instantaneous application of energy or force. (A shock will cause some vibration in an item or package.)

### 3. APPARATUS

3.1 A platform of suitable size and weight-carrying capacity supported on a mechanism that will maintain the surface essentially horizontal as it vibrates the platform so that the vertical component of the motion is approximately sinusoidal. (A rotary motion of the platform is acceptable.) The amplitude of the vibration shall be 1/2 inch (1-inch double amplitude). The frequency shall be variable within the approximate range from 3 to 5 Hz and shall be controlled to produce the platform vibration specified in 6.

3.2 Restraining devices. Fences, barricades, or blocking that can be attached to the platform to keep the specimen in position on the platform without unnecessarily restricting the vertical or rotational movements of the specimen.

4. SPECIMENS

4.1 One container and its contents shall constitute a single specimen. The container shall be loaded for the test with the interior packing and the actual contents for which it was designed. If use of the actual contents is not practical, a dummy load shall be substituted to simulate such contents in weight, weight distribution, rigidity, shape, and position in the container. The contents, or dummy load, shall be blocked, braced, and cushioned in place as for shipment.

4.1.1 If the intended contents, or a fully representative dummy load such as a reject item are to be used in the package, their condition before and after test must be determined by appropriate methods to establish the extent of damage suffered in the test.

4.1.2 If a dummy load is to be used, unless it is fully representative of the intended contents, the ability of the package to prevent damage can be determined only by indirect methods such as comparison of accelerations measured on the dummy load and fragility factors for the intended contents.

5. CONDITIONING

5.1 Unless otherwise specified, no special conditioning of the specimen shall be necessary. The condition of the specimen and any tests performed prior to the vibration test shall be recorded.

6. PROCEDURE

6.1 The specimen shall be placed on but not fastened to the platform. If the specimen might be shipped in other than an upright position, the specimen shall be placed in such a position; and if more than one position is reasonable, the test shall be interrupted and the position changed so that the specimen is tested for equal periods of time in each reasonable shipping position. Midway in the period of time that the specimen is tested resting on each surface, the specimen shall be rotated 180° if the specimen rocks on the platform. Unless failure occurs, the total time of vibration shall be 2 hours if the specimen is tested in one position; and if tested in more than one position, the total time shall be 3 hours.

6.2 Restraining devices shall be attached to the platform to prevent the specimen from moving off the platform and, if necessary, to prevent excessive rocking of the specimen. The restraining devices should be adjusted to permit unrestrained movement of the specimen from its centered position about 1/2 inch in any horizontal direction.

6.3 With the specimen in one position, vibrate the platform at 1/2-inch amplitude (1-inch double amplitude) starting at a frequency of about 3 cycles per second. Steadily increase the frequency until the package leaves the platform (i.e., until a 1/16-inch-thick "feeler" may be momentarily slid freely between every point on the specimen and the platform at some instant during each cycle) or until the frequency reaches that at which the maximum platform acceleration is  $1 \pm 0.1$  times the acceleration of gravity. If circular input motion is used, table frequency shall be adjusted to assure that one edge of the container leaves the table not less than 3/16 inch on each cycle. This test is normally conducted at an ambient temperature of  $70^{\circ} \pm 20^{\circ}$  F. While observing to detect development of any failure, continue to vibrate at such frequency until the total time of vibration in the position is completed. Observe and record whether or not the specimen leaves the platform and the frequency maintained.

6.4 If the specimen is to be tested in more than one position, repeat 6.3 for each position.

6.5 After the total period of vibration is completed, inspect the packaging and the contents for evidence of damage. Make appropriate functional or other tests to establish whether or not the item suffered damage.

## 7. REPORT

7.1 Immediately following each test the report (official record) of the facts pertinent to the test shall be completed, and shall include the following:

7.1.1 A statement that the test was conducted in compliance with this procedure, or a description of the deviations from this procedure. Report all options selected and details of otherwise specified procedure that were followed as permitted in (3) Identify apparatus and its limits, (5) Conditioning, (6) Procedure selections and specifically identify instrumentation.

7.1.2 Identification of the specimen, the specific packaging, and contents tested.

7.1.3 Results of the test. State the frequency of vibration in each test position and whether or not the specimen left the platform. Describe any damage to the packaging or contents, or state no damage. Record pertinent dimensions taken before, during or after the test. Refer to any supplementary tests to evaluate effects of this vibration test.

7.1.4 When the test is performed to check compliance with the requirements, state that the specimen did not meet the requirements and give the source for the requirements.

7.1.5 When the test is conducted to evaluate or compare products or methods, the report shall include a statement of any observations that may lead to improvements. The report shall include a statement that the container or pack either attained or did not attain the specified performance. If not specified elsewhere, it is suggested that the following be cause for rejection:

- (a) Functional or physical damage to the contents.
- (b) Functional damage to the container.
- (c) Shock forces on the contents (or dummy load) which exceeds the established fragility of the contents.
- (d) Failure of a vapor or waterproof container to prevent vapor transmission or water leakage within specified limits.
- (e) Structural damage to the container which may result in damage to the contents during subsequent shipping, handling, or storage. Substantial spillage, exposure, or shifting of the contents are examples of such damage. Minor damage such as dents, paint chipping, or the crushing of wood members which do not impair the function of the container are not causes for rejection.

8. NOTES

8.1 Not applicable.

VIBRATION (SINUSOIDAL MOTION) TEST

1. SCOPE

1.1 This procedure is appropriate for testing packages containing items that might be susceptible to vibration encountered during shipment by common carrier. In particular, the method simulates application of the rectilinear components of the probable shipping vibration environment to packages that are tied down to the floor of the carrier in transit. The test method is intended for packages that contain susceptible items which will be tied down to the floor of the carrier (both, not either).

1.2 By testing according to this procedure it will be possible to determine the following:

a. The probable ability of the packaging to withstand the shipping vibration environment for the conditions given in 1.1.

b. The probable adequacy of the packaging to protect the item from shipping vibration. To serve this function the actual item should be used rather than a dummy load, and functional tests before and after vibration should be performed.

2. DEFINITION

2.1 Octave. A change in frequency by a factor of either 2 or 0.5.

3. APPARATUS

3.1 A platform of suitable size and weight-carrying capacity supported on a mechanism that will maintain the surface essentially horizontal as it vibrates the platform vertically in linear motion. For this motion the relationship between displacement and time shall be approximately a sine wave. Controls of the motion shall be capable of producing the test envelope shown in figure 1. Two machines one to operate below 5 Hertz (Hz) and one to operate above 5 Hz, may be used.

3.2 A fixture to anchor the specimen to the platform. Neither the fixture nor the platform should have a natural frequency within the range specified in 6.2. If unavoidable, the natural frequencies shall be recorded; and the test data at these frequencies shall be interpreted with appropriate reservations.

3.3 Instrumentation shall have a flat (± 5 percent) response within the frequency range specified in 6.2.

4. SPECIMENS

4.1 One container and its contents shall constitute a single specimen. The container shall be loaded for the test with the interior packing and the actual contents for which it was designed. If use of the actual contents is not practical, a dummy load shall be substituted to simulate such contents in weight, weight distribution, rigidity, shape, and position in the container. The contents, or dummy load, shall be blocked, braced, and cushioned in place as for shipment.

4.1.1 If the intended contents or a fully representative, dynamically similar dummy load, such as a reject item, are to be used in the package, their condition before and after the vibration test must be determined by appropriate methods to establish the extent of damage suffered during the vibration test.

4.1.2 If a dummy load is to be used, unless it is fully representative of the intended contents, the ability of the packaging to prevent damage can be estimated by indirect methods, such as comparison of accelerations measured on the dummy load and fragility factors for the intended contents, or other indirect comparisons.

5. CONDITIONING

5.1 Unless otherwise specified, no special conditioning of the specimen shall be necessary. The condition of the specimen and any tests performed prior to the vibration test shall be recorded.

6. PROCEDURE

6.1 Attach the specimen securely on the platform so that no point can lift off the platform during vibration. If the specimens might be shipped in other than an upright position, the specimen shall be in such a position; and if more than one position is reasonable, the test shall be extended and the position changed so that the specimen shall be tested in each reasonable shipping position. Attach electric resistance-type strain gages, accelerometers, or other sensors to strategic areas of the specimen as appropriate for the purpose of the test.

6.2 Unless otherwise specified, operate the apparatus for 2 hours as follows for each position of the specimen to encompass the test envelope shown in figure 1.

6.2.1 For the first 15 minutes maintain amplitude constant at  $1/2 + 1/32$  inch ( $1 + 1/16$  inch double amplitude) and either vary the frequency to repeatedly sweep at 2 minutes per octave from 2 to 5 Hz and return, or maintain for 5 minutes each a constant frequency at 2, 3, and 5 Hz.



6.2.1.1 This portion of the test may be deleted if it is determined that there are no elements of the test specimen which have a natural resonant frequency of less than 10 Hz. In this case the total time of the second part of the test would be increased by 15 minutes (to 120 minutes).

6.2.2 For the last 105 minutes maintain the relationship between frequency and amplitude shown in figure 1 as the frequency is progressively changed from 5 Hz to the maximum and return to 5 Hz not less than four times. The maximum frequency shall be determined on the basis of specimen weight as follows:

Weight of specimen	Maximum frequency
Lb.	Hz
100 or less .....	500
300 or more .....	50
Between 100 and 300 ...	(725 - 2.25 x weight)

For apparatus in which the frequency and the amplitude may be varied, continuously sweep the frequency at not less than 2 minutes per octave. For apparatus in which the amplitude may be varied only in increments, the amplitudes of the platform motion, frequencies, and durations shall be as follows:

Double amplitude constant	Frequency (f), either <sup>1</sup>		Minimum duration of vibration
	Sweep between f/1.23 and 1.23f	Constant	
In.	Hz	Hz	Sec.
0.673	5.0 to 7.56	6.15	70
.295	7.56 to 11.44	9.30	70
.129	11.44 to 17.30	14.07	70
.055	17.30 to 26.6	21.6	70
.036		32.7	70
.036		49.5	35
.036	26.6 to 50.0		105
.036	50.0 to 26.6		105
.036		49.5	35
.036		32.7	70
.055	26.6 to 17.30	21.6	70
.129	17.30 to 11.44	14.07	70
.295	11.44 to 7.56	9.30	70
.673	7.56 to 5.0	6.15	70

<sup>1</sup> Either use the constant frequency or, preferably, sweep the range of frequency at not less than 2 minutes per octave.

6.2.3 During operation of the apparatus, either record or monitor the output of the sensors on the apparatus and on the specimen. Record any indications of resonance.

6.3 Unless otherwise specified, when resonance is indicated in 6.2, the specimen shall be tested an additional 15 minutes at each resonant frequency. The vibration of the platform shall be as shown on figure 1, and the frequency shall start at resonance and shall be adjusted, if necessary, to maintain resonance.

6.3.1 Dwell test at resonance, variations in frequencies, or amplitude may be modified by the design activity.

6.4 Inspect the specimen (packaging and contents) and record any evidence of damage. Make appropriate functional or other tests and record results to establish whether or not the item suffered damage during the vibration test.

## 7. REPORT

7.1 Immediately following each test the report (official record) of the facts pertinent to the test shall be completed, and shall include the following:

7.1.1 A statement that the test was conducted in compliance with this procedure, or a description of the deviations from this procedure. Report all options selected and details of otherwise specified procedure that were followed. Identify: Apparatus and its limits (3). Sensors and their locations (4.1). Conditioning and any functional tests before vibration (5.1). Procedure options, resonant frequencies, and functional tests after vibration (6).

7.1.2 Identification of the specimen, the specific package and the item tested.

7.1.3 Results of test. Describe any damage or failures. Record any measurements before, during, or after test. Refer to any supplementary tests to evaluate effects of vibration.

7.1.4 When the test is performed to check compliance with requirements, state that the specimen did or did not meet the requirements and give the source for the requirements.

7.1.5 When the test is conducted to determine satisfactory performance of a container or pack, the report shall include a statement that the container or pack either attained or did not attain the specified performance. If not specified elsewhere, the following shall be cause for rejection:

- (a) Damage to the contents. Such damage may be established by either functional tests or other specific evidence of sensitivity to the test condition.
- (b) Damage or permanent deformation of any portion of the container that effects its functional performance.
- (c) Structural failure of the isolation system.
- (d) Failure of the isolation system to meet specified transmissibility or resonant frequency requirements.
- (e) Excessive looseness of contained article.
- (f) Failure of isolation system to prevent contents from striking container walls.
- (g) Leakage in excess of specified criteria.
- (h) Excessive rotation of the contents which could cause damage.

8. NOTES

8.1 Not applicable.

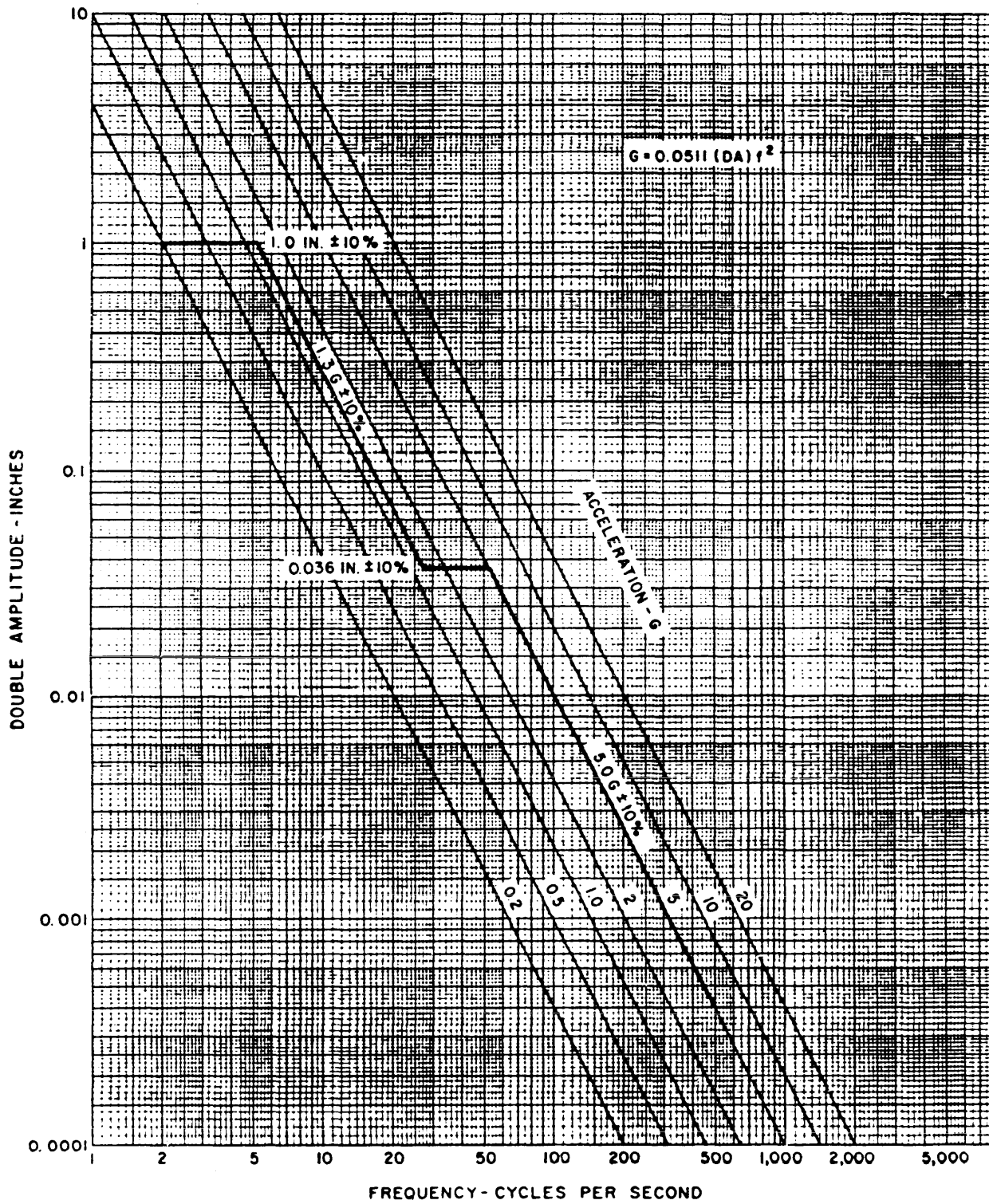

Figure 1. Test envelope 2 to 500 cycles per second for vibration (sinusoidal motion) test.

BASIS WEIGHT OF PAPER AND PAPERBOARD

PROCEDURE A

1. SCOPE

1.1 This method covers the procedure for determining the basis weight of paper and paperboard.

2. DEFINITIONS

2.1 Basis weight. The weight of a specified area of the material.

2.2 Specimen. A single sheet or piece of the material.

3. APPARATUS

3.1 A basis weight balance or other balance with a sensitivity of not more than 0.5 percent of the load applied and so graduated that readings of this degree of accuracy can be made. The balance scale may be graduated to indicate the basis weight directly when one sheet of designated size is weighed. The balance shall be in calibration, level, and protected from air currents.

3.2 A paper cutter. An attachment for the paper cutter to insure parallelism of opposite edges of the trimmed sheet is recommended. Templates may also be used for cutting test specimens. When using a template, a sharp knife or razor blade is required for cutting the specimen.

4. SPECIMEN

4.1 Unless otherwise specified, the number of specimens of paper shall consist of not less than 10 sheets each at least 100 square inches (645 sq. cm.) in area, and the specimens of paperboard shall consist of not less than 5 sheets each at least 1 square foot in area. The manner of selection, unless otherwise specified, shall be in accordance with the appended TAPPI Standard T 400 m-49, "Sampling of Paper and Paperboard for Testing."

5. CONDITIONING OF SPECIMENS

5.1 All surfaces of specimens shall have free access to the conditioning atmosphere and the time shall be sufficient for the specimen to attain a moisture content in equilibrium with the conditioning atmosphere.

5.2 Unless otherwise specified, the specimens shall be conditioned to equilibrium in a uniformly maintained atmosphere of  $73^{\circ} \pm 3.5^{\circ}\text{F}$ . and  $50 \pm 5$  percent relative humidity.

5.3 A specimen shall be considered at equilibrium when the change in weight during a 1-hour or longer period of conditioning does not exceed 0.02 percent of the specimen's weight at the end of the period.

## 6. PROCEDURE

6.1 The test shall be made in the conditioning atmosphere. The area of the specimen shall be determined within  $\pm 1$  percent. This will require a precision of 0.5 percent in measuring the dimensions (approximately  $\pm 1/16$  inch in a length of 10 inches). The weight of the specimen shall be determined within a tolerance of  $\pm 0.5$  percent. From these measurements calculate either the weight per ream or weight per unit area of specimen.

6.2 Calculate the basis weight of the base paper in creped, asphalted, or resin-coated papers by the formula:

$$A = \frac{B}{\left(1 + \frac{C}{100}\right) \times \left(1 + \frac{D}{100}\right) \times \left(1 + \frac{E}{100}\right)}$$

where:

- A = basis weight of base paper.
- B = basis weight of tested specimens.
- C = percent of crepe in one direction.
- D = percent of crepe in other direction.

(Percent crepe may be determined as follows: Cut representative strips with parallel edges from 1/2 to 1 inch wide in the machine direction and in the cross-machine direction, preparing a minimum of three specimens for each. Make a pencil line about 1 inch from the end of each strip and another at an exact distance of 4 to 10 inches. Place the strip on a rule with one of the marks near an inch division, hold the sample at both ends, and stretch to its maximum elongation. Measure the new distance between the marks. Then calculate the percentage crepe as the increase in distance multiplied by 100 and divided by the original distance.)

- E = percent of asphalt or of resin (see asphalt content test method or supplier of material).

Omit the factors in the above formula that do not apply.

7. REPORT

7.1 Following the test a report shall be written which shall include the following:

7.1.1 A statement that the test was conducted in compliance with this procedure, or a description of the deviation from this procedure. Report all options selected and "otherwise specified" details that were followed as permitted in 4.1 and 5.2.

7.1.2 Report the basis weight of paper to three significant figures in pounds per ream of sheets of stated number and size, or in grams per square meter. Report the basis weight of paperboard in pounds per 1,000 square feet, or in grams per square meter.

8. NOTES

8.1 Details are given with the qualification, "unless otherwise specified," in paragraphs regarding:

- Selection of specimens (4.1).
- Conditioning of specimens (5.2).

8.2 Basis weight may be converted from one system of units to another by multiplication using the appropriate factor from the following tabulation:

Trade units	Conversion factors	
	Trade units to grams per sq. meter	Grams per sq. meter to trade units
Lb. per ream of 500 sheets, 24 x 36 inches .....	1.627	0.614 Lb. per
ream of 480 sheets, 24 x 36 inches .....	1.690	.592 Lb. per
ream of 500 sheets, 22 x 28 inches .....	2.282	.438 Lb. per
ream of 500 sheets, 20 x 30 inches .....	2.343	.427 Lb. per
1,000 sq. ft. ....	4.881	.205

For examples, a basis weight of 40 pounds per ream of 500 sheets 24 x 36 inches should be multiplied by the factor 1.627 to convert to basis weight in grams per square meter (65 grams per square meter). To convert a basis weight of 250 grams per square meter to basis weight in pounds per 1,000 square feet, multiply the 250 by 0.205, which equals 51.25 pounds per 1,000 square feet.

METHOD 5022.1  
March 13, 1980

PROCEDURE B

ASTM D-646-67 BASIS WEIGHT OF PAPER AND PAPERBOARD TEST FOR

1. SCOPE

1.1 When specified in the commodity specification, contract or order, Procedure B may be used in lieu of Procedure A except that levels of intensities shall be those specified in Procedure A.

PROCEDURE C

TAPPI T410 - WEIGHT PER UNIT AREA (BASIS WEIGHT OR SUBSTANCE)  
OF PAPER AND PAPERBOARD

1. SCOPE

1.1 When specified in the commodity specification, contract or order, Procedure C may be used in lieu of Procedure A except that levels of intensities shall be those specified in Procedure A.



## INCLINE-IMPACT TEST

### 1. SCOPE

1.1 The following procedure is applicable for determining the ability of shipping containers to resist impacts on their surfaces or edges, and for determining the ability of the packaging and packing methods to provide protection to the contents when the pack is impacted on its surfaces or edges. This test may be applied also to unitized loads.

### 2. DEFINITION

2.1 For the purpose of this test, an incline-impact tester shall consist of a two-rail steel track inclined 10 degrees from the horizontal, a rolling carriage or dolly, and a rigid bumper (see 3).

### 3. APPARATUS

3.1 The inclined track shall accommodate the carriage which shall be equipped with steel wheels, not less than 3 inches in diameter, and a renewable face made of dense hardwood or plywood. The bumper at the bottom of the incline shall be constructed integrally with the track and with the plane of its face perpendicular to the direction of movement of the carriage. The bumper shall be faced with dense hardwood members of such thickness as to resist the impacts without breakage or excessive deflection. The faces of the bumper and the carriage shall be kept free of any protections, such as bolts or nailheads, abrasions, and splits that might affect the test results. The track shall be clean and the wheels well lubricated. The apparatus may also have a cable and winch to aid in pulling the carriage to the elevated end of the track, and an automatic tripping device for releasing the carriage from a predetermined point of the incline. A detailed description of this apparatus with construction drawings appears in "Freight Container Bulletin 673," Freight Loading and Container Section, Association of American Railroads, 202 Union Station, 516 W. Jackson Blvd., Chicago, Ill. 60606 and in ASTM D 880-50.

### 4. SPECIMEN

4.1 One container and its contents shall constitute a single specimen. The container shall be loaded for the test with the interior packing and the actual contents for which it was designed. If use of the actual contents is not practical, a dummy load shall be substituted to simulate such contents in weight, shape, and position in the container. The contents, or dummy load, shall be blocked, braced, and cushioned in place as for shipment.

5. CONDITIONING OF SPECIMEN

5.1 Unless otherwise specified, no special conditioning of the test specimen shall be necessary.

6. PROCEDURE

6.1 The specimen shall be placed on the carriage with the surface or edge which is to be impacted projecting at least 2 inches beyond the front end of the carriage. The carriage shall be brought to a predetermined position on the incline and released. If it is desired to concentrate the impact at any particular position on the container, a 4- by 4-inch timber may be attached to the bumper in the desired position before the test. No part of the timber shall be struck by the carriage. The position of the container on the carriage and the sequence in which the the surfaces and edges are subjected to impacts may be at the option of the testing activity and will depend upon the objective of the tests. When the test is conducted to determine satisfactory performance of a container or pack, and unless otherwise specified, the specimen shall be subjected to one impact on each surface that has each dimension less than 9.5 feet. Unless otherwise specified, the velocity at time of impact (which may be assumed equal to twice the average velocity) shall be 7 feet per second.

6.2 A record shall be made of each impact to show velocity at impact and any changes or breaks in the container, such as apparent racking, nail pull, or broken parts and their locations. The packing (blocks, braces, cushions, or other devices) and the contents shall be examined carefully and a record made of their condition.

7. REPORT

7.1 Following the test a report shall be written which shall include the following:

7.1.1 A statement that the test was conducted in compliance with this procedure or a description of the deviation from this procedure. Report all options selected and "otherwise specified" details that were followed as permitted in 5.1 and 6.1. State whether 4 x 4 timber was used on the bumper and identify area of container contacted, such as base, midheight, or top edge.

7.1.2 Dimensions of the container, its structural details, kind of materials, spacing, size and type of fasteners, methods of closing and strapping, and the net and gross weights.

7.1.3 A description of the contents of the container including blocking, bracing, and cushioning.

7.1.4 The results of the test, describing the final condition of both container and contents.

7.1.5 When the test is conducted to determine satisfactory performance of a container or pack, the report shall include a statement that the container or pack either attained or did not attain the specified performance. If not specified elsewhere, it is suggested that satisfactory performance shall consist of:

"When subjected to the incline-impact test, the contents (except a dummy load) shall show no functional or physical damage, and the container and packing shall show no functional damage. Damage to the exterior shipping container which is the result of improper interior packaging, blocking, or bracing shall be cause for rejection. Structural damage to the exterior shipping container which would result in either spilling of the contents or failure of the container in subsequent handling is cause for rejection. There shall be no evidence of a substantial amount of shifting of the contents within the exterior shipping container that would create conditions likely to cause damage during shipment, storage, and reshipment of the container. Minor container damage, such as chipping of wood members, dents, paint chipping, is not cause for rejection."

7.1.6 The report should include a statement of any observations that might help in improving the container or the methods of packing.

## 8. NOTES

8.1 This test is meant to simulate railroad humping, switching, or other accidental handling impacts. It is intended that the incline-impact test shall be used only on containers that are susceptible to such accidental impacts. Details are given with the qualification "unless otherwise specified" in paragraphs regarding:

Conditioning of specimens (5.1).  
Number and velocity of impacts (6.1).

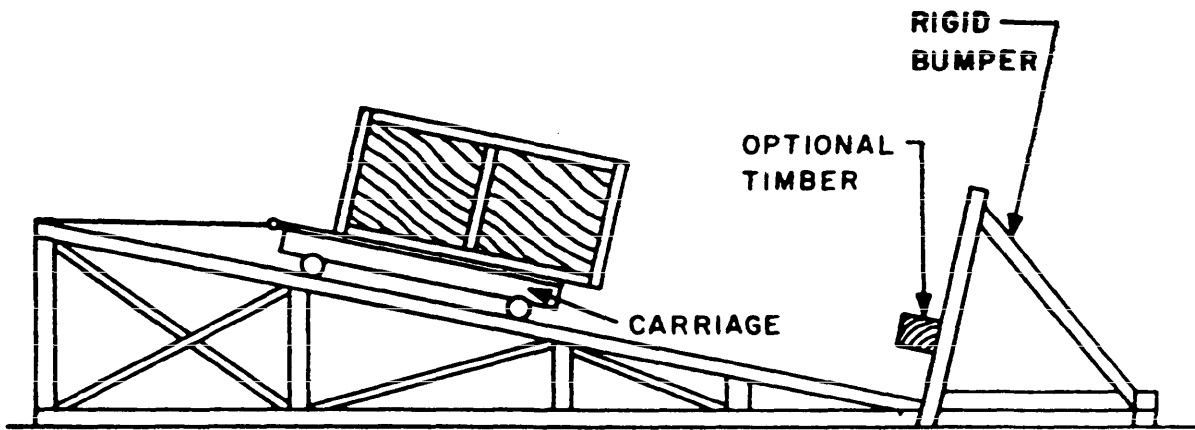

Figure 1. Incline-impact test.

DETERMINATION OF GASEOUS OXYGEN IN HERMETICALLY  
SEALED CONTAINERS

1. SCOPE

1.1 This procedure is designed to determine the percentage of gaseous oxygen remaining the flexible or rigid packages which have been hermetically sealed under an atmosphere of inert gas. Test procedures will destroy the integrity of the packages being tested.

2. DEFINITIONS

2.1 Not applicable.

3. APPARATUS

3.1 The apparatus shall be a semimicro or a standard-size Orsat-type gas analyzer, consisting of a leveling bulb, gas measuring burette, manometer, two gas absorption pipettes, connecting manifold with stopcocks, and gas sampling device. If the leveling bulb does not extract an adequate sample because of a high vacuum within the package, another manifold connected to a gas sampling reservoir with a leveling bulb, a source of vacuum, and a mercury manometer, may be added between the analyzer and the sampling device. The glassware shall be alkali-resistant, and the flexible connections shall be made of Tygon.

3.1.1 The leveling bulb shall have a capacity of 125 ml and shall be connected at the bottom of the gas burette.

3.1.2 The gas burette shall have a two-way stopcock at the top and be calibrated to one-thousandth of its total capacity. The volume of the semimicro Orsat burette shall be 2, 5, or 10 ml, while that of the standard size shall be 50 or 100 ml. One arm from the stopcock shall connect to the Orsat manifold, the other to the sampling device or the sampling manifold.

3.1.3 The manometer shall be a U-tube constructed to capillary tubing and shall be connected to a sidearm on the manifold through a stopcock.

3.1.4 The gas absorption pipettes shall have a large surface area wetted by the absorbing solution. Each absorber shall have a pressure relief gas bag attached to it and shall be connected to the manifold through a stopcock.

METHOD 6011.1  
March 13, 1980

3.1.5 The manifolds shall be constructed of glass capillary tubing with stopcocks. The connecting manifold shall have a stopcock on the free end opening to the atmosphere and have sidearms with stopcocks leading to the gas pipettes and the manometer. The other end of the manifold shall attach to one arm on the two-way stopcock of the gas burette. A hypodermic sampling device or the added manifold shall attach to the other arm of the stopcock. The sampling manifold shall have sidearms with stopcocks to connect to a sampling reservoir, a vacuum source, a mercury manometer and a sampling device.

The manifold shall terminate through a stopcock to the atmosphere.

3.1.6 The sampling device for flexible containers shall be a section of a No. 20 hypodermic needle, without the shank, fused into a section of capillary tubing and attached to a sidearm of the gas burette. For rigid containers a headspace sampling device manufactured by Precision Scientific Company or its equivalent, shall be used to pierce the can under vacuum. (Catalog, 70, Fisher Scientific Company, Catalog No. 13-299-75).

### 3.2 Reagents.

3.2.1 Potassium hydroxide solution. Dissolve 60 grams of KOH, reagent grade, in 60 ml. of distilled water.

3.2.2 Alkaline pyrogallol solution. Dissolve 1.5 grams of pyrogallol, reagent grade, in 30 ml. of the potassium hydroxide solution. Alternatively, a commercially prepared oxygen absorbent with an acid base may be used.

3.2.3 Mercury. About 3 pounds of mercury, reagent grade.

3.2.4 Manometer solution. Dissolve 0.01 gram of amaranth in 7.6 ml. of 1 percent Tergitol solution; dilute to 100 ml. with distilled water.

3.2.5 Acceptable alternate methods for measuring head space O<sub>2</sub> hermetically sealed containers include the use of:

(a) Paramagnetic type O<sub>2</sub> analyzer (0-100% range)

(b) Polarographic O<sub>2</sub> sensor (0-100% range)

### 4. SPECIMENS

4.1 Specimens shall be representative of the lot of packages.

5.           CONDITIONING

5.1           Not applicable.

6.           PROCEDURE

6.1           Preparation for analysis. Assemble semimicro or standard Orsat apparatus, selecting the burette and sampling device for the amount of gas available in the sample. Half fill the manometer with manometer solution. Fill the leveling bulb with mercury. Introduce about 1.0 ml of the manometer solution so that it floats above the mercury in the gas burette. Fill the gas pipettes with the proper solutions. Saturate the absorbers by passing four air samples through the absorber, first through the carbon dioxide absorber (KOH solution) and then through the oxygen absorber without recording the results. This operation provides inert gas for the manifold, manometer, and absorber system. Check reagents and apparatus by analyzing a known sample or a sample of air using the technique outlined below. If air is used, 0.03 percent carbon dioxide and 20.99 percent oxygen are the theoretical percentages which should be obtained.

6.2           Determination of oxygen content in flexible packages.

6.2.1         With any effective cement, such as Contact, seal a disc or pad of soft rubber (i.e., 25 to 40 Durometer hardness by test method 3021 of Federal Standard 601) to the package being tested. Pads should measure about 3/4 x 3/4 x 3/16 inch. If the package is thin, attach a pad to each side. A small mass of General Electric Adhesive/Sealant RTV forming a blob about 3/16-inch thick by 5/8-inch in diameter may be used instead of the rubber disc. To avoid clogging the needle, allow the sealant to dry about 24 hours.

6.2.2         Close all stopcocks on the gas analyzer apparatus. Open the sampling stopcock and pump mercury until the liquid just reaches the tip of the sampling device. Close the stopcock and insert the needle by forcing the pad against the needle so the needle just penetrates the interior of the package. Open the sampling stopcock and withdraw possible gas sample by lowering the leveling bulb. Close the sampling stopcock and open the manifold and manometer stopcocks. Adjust to atmospheric pressure by means of the manometer and the leveling bulb. Close the manometer stopcock. Record initial volume  $V_1$ .

Open the stopcock to the carbon dioxide absorber and pump the gas sample in and out to constant volume (about five times). Bring the liquid in the absorber to the meniscus mark, close the absorber stopcock, adjust to atmospheric pressure, and record volume  $V_2$ .

Open the oxygen absorber stopcock and proceed in the same manner as with the carbon dioxide analysis. Close the stopcock, adjust to the meniscus mark and then to atmospheric pressure and record volume  $V_3$ .

$$\text{Oxygen, percent by volume} = (V_2 - V_3) \times \frac{100}{V_1}$$

$$\text{Carbon dioxide, percent by volume} = (V_1 - V_2) \times \frac{100}{V_1}$$

### 6.3 Determination of oxygen content in rigid containers.

6.3.1 Sampling. The apparatus shall be the standard size Orsat analyzer with a 50 to 100 ml gas burette. Saturate the absorber with air as in paragraph 6.1. Position the rubber gasket of the sampling device against a flat surface of the container; open the stopcock to the vacuum source. When the vacuum has reached its maximum, as determined by the mercury manometer, close the stopcock and pierce the container with the sampling device. Open the stopcock of the gas sampling reservoir, withdraw the maximum sample from the container into the reservoir, close the stopcock, and adjust to atmospheric pressure. Analyze for carbon dioxide and oxygen in the same manner as 6.2.2.

## 7. REPORT

7.1 Immediately following each test the report (official record) of the facts pertinent to the test shall be completed and shall include the following.

7.1.1 A statement that the test was conducted in compliance with this procedure, or a description of the deviation from this procedure. Report all options selected and details of otherwise specified procedure that were followed as permitted in 3.2.2, 6.1, and 6.2.1.

7.1.2 Identification of the specimen.

7.1.3 Results of the test. State the oxygen content as a percentage of the volume of the gas sample withdrawn for analysis.

7.1.4 When the test is performed to check compliance with requirements, state that the specimen did or did not meet the requirements and give the source of the requirements.



7.1.5 When the test is conducted to evaluate or compare products or methods, the report shall include a statement of any observations that may lead to improvements.

7.1.6 The contractor may use methods other than those specified in this method (see 3.2.5); however, in the event of disagreement, the contractor will use the procedure set forth herein for the semimicro or standard Orsat gas analysis.

## 8. NOTES

8.1 Pertinent information related to this method appears in the following publications:

Semimicro Orsat Method, McMullen and Stark, Journal of the Association of Official Agricultural Chemists, August 1954, Vol. 37, No. 3, pages 856 to 860.

Standards for Grades for the Dry Milk Industry Including Methods of Analysis, Bulletin 916, American Dry Milk Institute publication.

8.2 Normally, when the Orsat apparatus is checked against air, CO<sub>2</sub> cannot be measured unless a burette of greater capacity is used (6.1).

8.3 Often in testing dehydrated food packages, the step involving removal of CO<sub>2</sub> can be eliminated. However, unless experience shows that the particular lot of food being tested does not contain a detectable amount of CO<sub>2</sub>, this step must be performed (6.2.2).

8.4 Alternative method for determining oxygen.

8.4.1 Gas chromatography. This method involves absorbing the sample in a column of inert granular packing material coated with a high boiling liquid. The column is heated and swept with helium with the gases coming off separately at distinct intervals. The thermal conductivity of each gas is measured and recorded on a chart, and the amount of each gas present is calculated from the area under the chart curve. From the total amount of gas shown on the chart, the percentage of oxygen can be calculated.

The gas chromatograph is capable of measuring extremely small samples, 0.001 ml. with some models, with a high degree of reproducibility, quickly and easily. However, it is not readily portable, and it requires a source of helium and electricity.



TEST FOR WEIGHT OF PHOSPHATE COATING

1. SCOPE

1.1 This procedure is designed to measure the weight of phosphate coating per unit of surface area, of an item, by weighing the specimen before and after completely removing the coating in a 5 percent chromic acid solution.

2. DEFINITIONS

2.1 Not applicable.

3. APPARATUS

3.1 Electrically heated glass pan, thermostatically controlled to maintain a 5 percent chromic acid solution at  $165^{\circ} \pm 5^{\circ}\text{F}$ .

4. SPECIMEN

4.1 Steel panels, 4 by 6 inches of the same metal and gage as used in the coated item, shall be processed through all the cleaning and phosphating steps along with the coated item. If it is not practical to process the individual specimens, sample containers may be cut to obtain the specimens. Where possible, coating weight measurements should be made on production items.

5. CONDITIONING

5.1 Not applicable.

6. PROCEDURE

6.1 The clean, dry specimen shall be accurately weighed to the nearest milligram and the dimensions of each shall be measured to the nearest 0.01 inch. Then the coating shall be completely removed by immersion in a 5 percent chromic acid solution at  $165^{\circ} \pm 5^{\circ}\text{F}$ . Submerge the specimen for 15 minutes, rinse, dry, and weigh the specimen. This procedure shall be repeated until constant weight is attained. The solvent shall be used for only one test.

6.2 Calculations.

6.2.1 Coating weight. The coating weight shall be computed as follows:

Coating weight (mg/ft<sup>2</sup>) =

$$\frac{(\text{Initial weight in grs.} - \text{Final weight in grs.}) \times 144,000}{\text{Total coated surface area in square inches}}$$

Milligrams per square foot can be converted to ounces per square foot by the following:

$$(\text{mg/sq ft}) \times (3.53 \times 10^{-5}) = \text{oz. (avoir.)}/\text{sq ft}$$

$$(\text{mg/sq ft}) \times (3.22 \times 10^{-5}) = \text{oz. (troy)}/\text{sq ft}$$

## 7. REPORT

7.1 Immediately following each test, the report (official record) of the facts pertinent to the test shall be completed, and shall include the following:

7.1.1 A statement that the test was conducted in compliance with this procedure, or a description of the deviations from this procedure. Report all options selected and details of otherwise specified procedure that were followed as permitted in 4.1.

7.1.2 Identification of the specimen and the specific material tested.

7.1.3 Results of the test. Weight of coating per square foot.

7.1.4 When the test is performed to check compliance with requirements, state that the specimen did or did not meet the requirements and give the source for the requirements.

7.1.5 When the test is conducted to evaluate or compare products or methods, the report shall include a statement of any observations that may lead to improvements.

## 8. NOTES

8.1 Details are given with the qualification, "unless otherwise specified," in the paragraph regarding:

Specimens (4.1).



